Application Guide

- Installation
- Startup



⚠ WARNING

This manual must only be used by a qualified heating installer/service technician. Read all instructions, including this manual and all other information shipped with the boiler, before installing. Perform steps in the order given. Failure to comply could result in severe personal injury, death or substantial property damage.



Contents

Section 1 - Safety

Hazard Definitions	5
Please Read Before Proceeding	6

Section 2 - Installation

General Piping	7
General Piping Requirements	7
Easy Up Manifold	7
Fabricated Manifold	8
Heat Pump/Boiler Piping Order	9
System Type	10
System Type A: WM Boiler w/ Unity 2.0 & WM Heat Pump	10
System Type B: WM Heat Pump & any Boiler with a Thermostat Input	11
System Type C: HP Only and Multi-HP	12
General Control Settings (HP, Boiler, TIU)	13
Weather Temp Set (Outdoor Reset)	14
FOR SERVICEMAN Mode	14
Save Settings and Quit FOR SERVICEMAN Mode ..	14
Heating Setting	15
Temp Type Settings	15
Room Thermostat	16
Other Heat Source	16
DHW Function	16
Heat Pump Control Schematic	17
Unity 2.0 AHD	18
Thermostat Interface Unit (TIU)	18

Section 3 - Applications

SYSTEM TYPE A

Application A1: Multi-zone space heating, DHW as zone	20
Application Piping	21
Application Wiring	22
Control Settings	24
Application A2: Multi-zone Space Heating, Boiler only DHW	26
Application Piping	27
Application Wiring	28
Control Settings	30

SYSTEM TYPE B

Application B1: Multi-zone space heating DHW as zone, boiler direct piped	32
Application Piping	33
Application Wiring	34
Control Settings	36
Application B2: Multi-zone space heating DHW as zone - Primary/Secondary	38
Application Piping	39
Application Wiring	40
Control Settings	42
Application B3: Multi-zone Space Heating boiler only DHW	44
Application Piping	45
Application Wiring	46
Control Settings	48

SYSTEM TYPE C

Application C1: Multi-zone Space Heating	50
Application Piping	51
Application Wiring	52
Control Settings	54
Application C2: Multi-zone Space Heating	56
Application Piping	57
Application Wiring	58
Control Settings	59
Application C3: Multi-zone space heating DHW as zone	60
Application Piping	61
Application Wiring	62
Control Settings	64

Section 4 - Commissioning/Troubleshooting

General Commissioning	65
Troubleshooting	68
Error Codes	69
EcoCalc Value Records	73

Overview Configuration Steps / Walk-Through

It is important to follow the below setup process to best configure your installation.

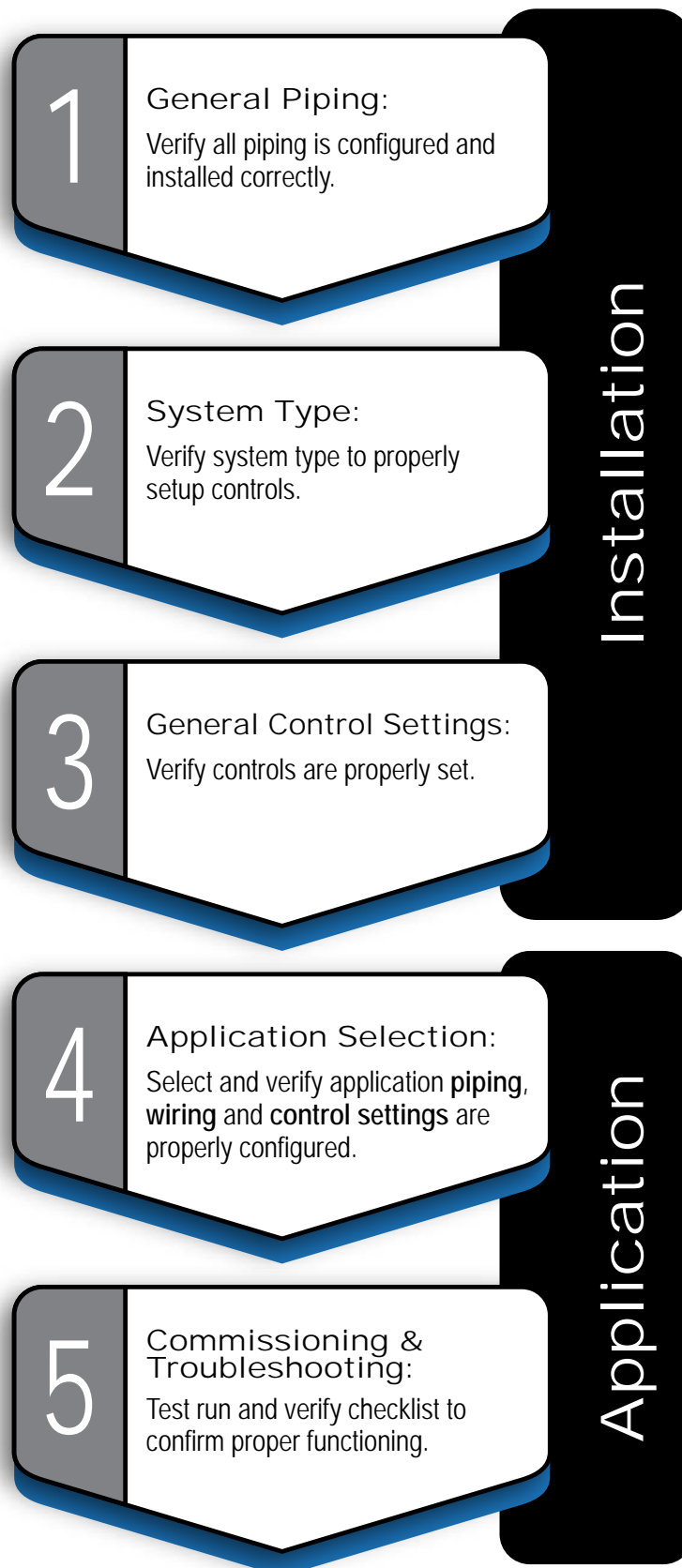



This page intentionally left blank.

SECTION 1

Safety

Hazard Definitions

The following defined terms are used throughout this guide to bring attention to the presence of hazards of various risk levels or to important information concerning the life of the product.

DANGER

Indicates presence of hazards that **will cause** severe personal injury, death or substantial property damage.

WARNING

Indicates presence of hazards that **can cause** severe personal injury, death or substantial property damage.

CAUTION

Indicates presence of hazards that **will or can cause** minor personal injury or property damage.

NOTICE

Indicates special instructions on installation, operation or maintenance that are important but not related to personal injury or property damage.

Please Read Before Proceeding

WARNING

This guide provides system application information only. It must be used only as a supplement to the Eco™HP Heat Pump manual and applicable code requirements. Before using this guide, refer to and follow all instructions in the Eco™HP IDU and ODU Manuals for initial installation.

NOTICE

This guide is meant to be used as a general guideline for piping and controlling Eco™HP heat pumps in a variety of applications. Some installations can be piped in numerous other ways that will work equally as well as the suggestions here.

Always follow recognized piping and control practices and all applicable codes. Provide and install all required controls on the boiler and system.

See the Contents listing and the Application finder to select the system closest to your needs. Refer to the boiler and heat pump manuals for details on expansion tank piping, relief valve piping and pipe sizing.

WARNING

Ensure water quality meets system water quality requirements detailed on [page 65](#). Failure to comply may result in heat pump failure or unreliable operation.

SECTION 2

Installation

General Piping

General Piping Requirements

The Eco™HP must always be piped in an isolation loop off of system distribution piping. Additionally, a heat trap must be installed. A Y-Strainer with 80 mesh screen must be installed before the inlet of the Eco™HP to prevent premature failure of the plate heat exchanger.

The circulator supplied with the Eco™HP must be used only in the HP secondary loop. System and Zone circulators and DHW circulators must be supplied by the installer.

If the WM Easy-Up Manifold (687-000-100) is not used, a manifold as described in the Fabricated Manifold Section (**Figure 2**) must be used. The Eco™HP water connections are 1" NPT. Header size is 1-1/4".

All piping must be sufficiently supported.

Boiler and heat pump placement should be configured according to operational need: (refer to **page 9**)

- If a heating system is limited by heat pump capacity, it will likely have significant concurrent boiler and heat pump operation. The heat pump should be piped in upstream of the boiler to prevent the heat pump return temperatures from rising too high.
- If a heating system is limited by heat pump supply temperature, it will likely have little to no concurrent boiler and heat pump operation and the heat pump may be piped in upstream or downstream of the boiler. However, it is best practice to pipe in the heat pump upstream of the boiler.

Easy Up Manifold

Weil-McLain offers an Easy-Up Manifold Kit that includes near Eco™HP piping and system secondary connection. Refer to instructions included in the Easy-Up Manifold Kit.

Figure 1 Easy Up Manifold

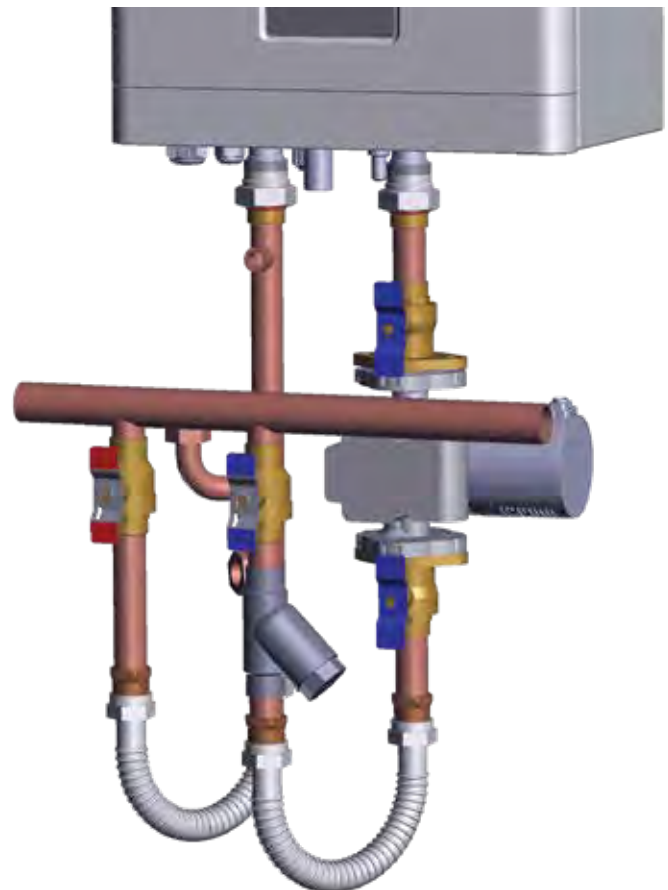

General Piping (continued)

Fabricated Manifold

If the WM Easy-Up Manifold is not used the following requirements must be met for an installer-built manifold:

- A heat trap height of at least 2 inches for both the inlet and outlet.
- **CAUTION**
A Y-Strainer with 80 mesh screen on the inlet (Y-Strainer must be oriented where flow direction is down or horizontal)
- The heat pump circulator can be placed anywhere in the heat pump isolation loop provided its orientation complies with the circulator manufacturer's installation guidelines.
- Common system piping must use either 1 inch diameter piping or the existing system piping diameter, whichever is greater.

A sample exploded view of a manifold using standard components is shown below:

Figure 2 Fabricated Manifold

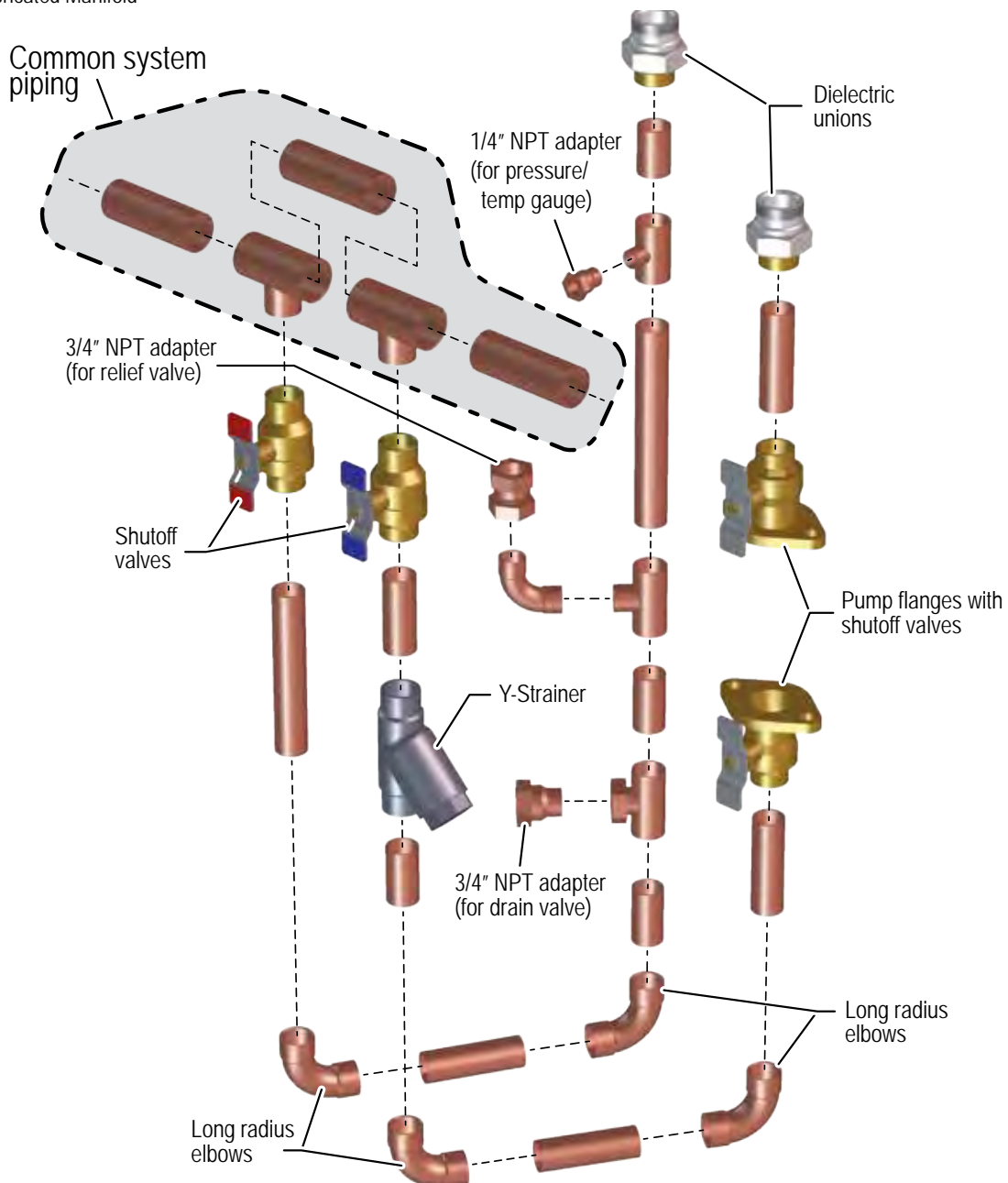

General Piping (continued)

Heat Pump/Boiler Piping Order

HP Upstream of Boiler

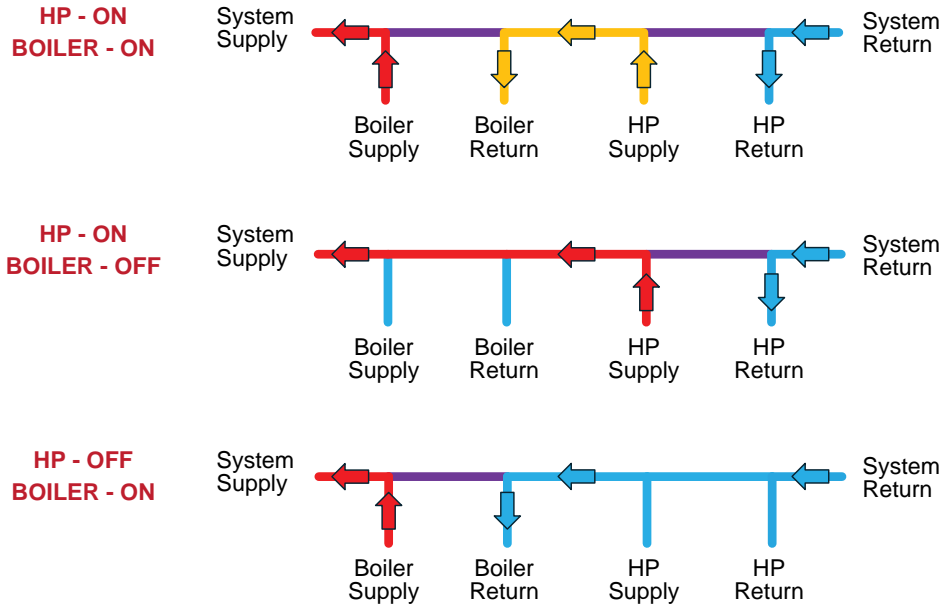

HP experiences system return temperatures when boiler is running, allowing concurrent operation with boiler.

HP Downstream of Boiler

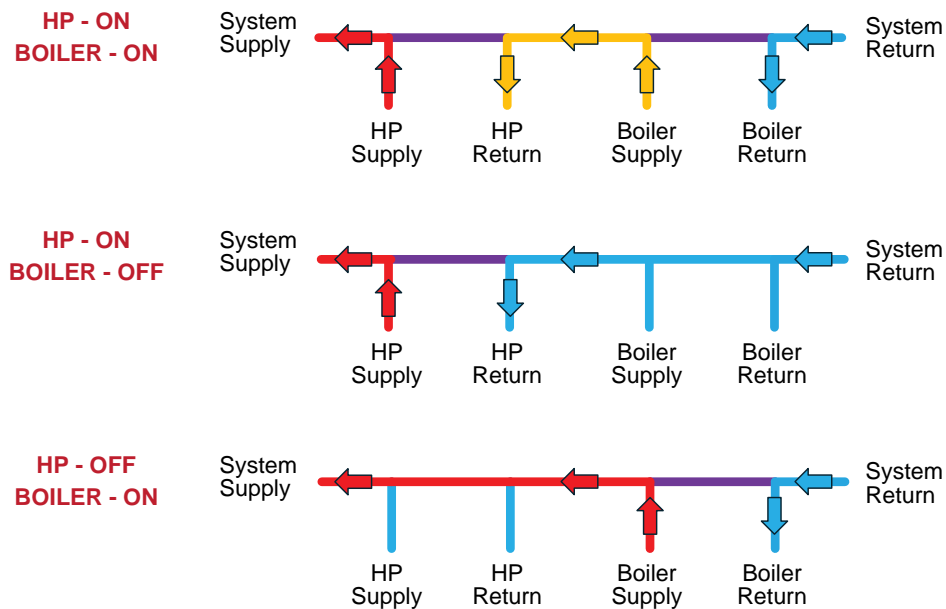

HP experiences high return temperatures when boiler is running, likely causing HP to shut down, preventing concurrent operation with boiler.

System Type

System Type A: WM Boiler w/ Unity 2.0 & WM Heat Pump

Figure 3 System Type A - Boiler (Master); Eco™HP (Shadow)

System Type A Boiler (Master); Heat Pump (Shadow)

Unity 2.0 boilers connect up to 4 zone inputs and 4 configurable outputs*

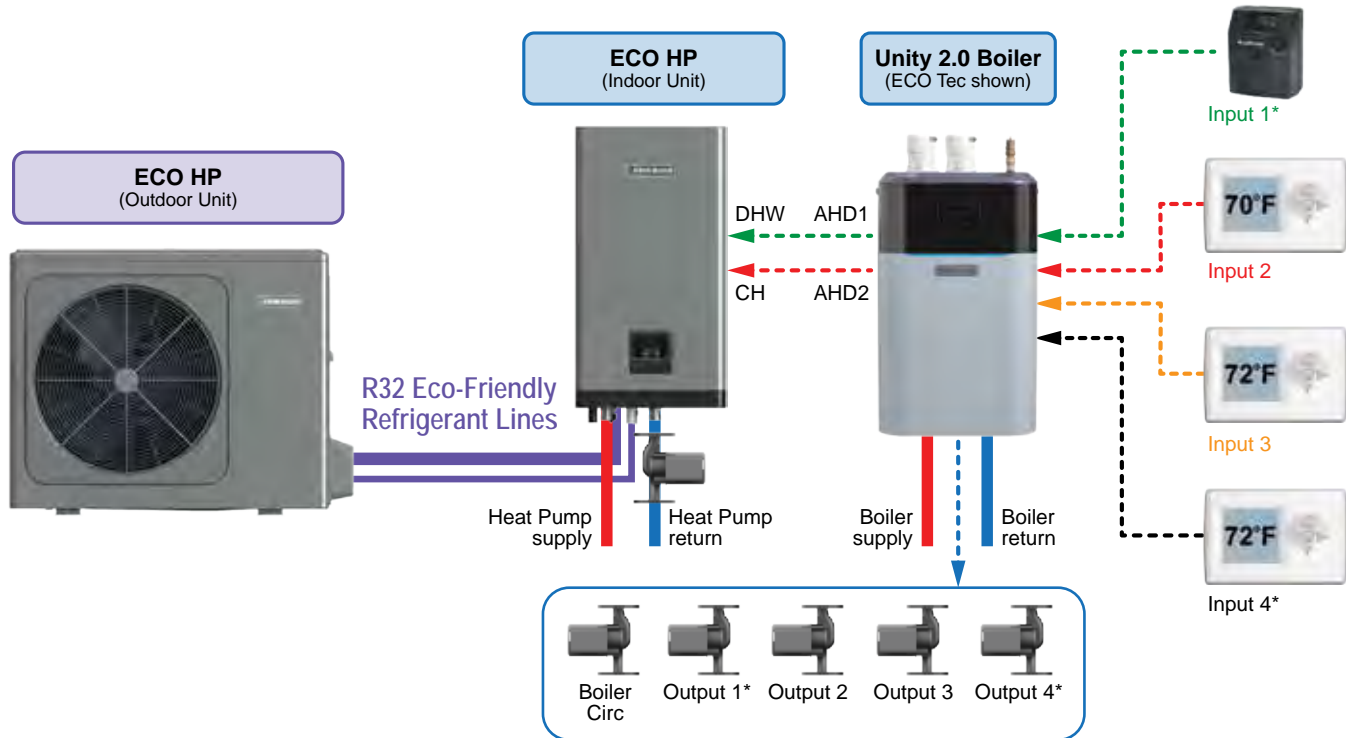

Type A Systems use a WM boiler with Unity 2.0 controllers as master. The boiler will determine when the heat pump will run and when the boiler will run. Up to 4 zones are supported natively*. Additional zones can be used with an appropriate zone panel such as the TIU detailed on [page 18](#).

The system call for heat will come from any of the zone thermostats into the associated WM boiler input. The heat pump will run when the boiler's Additional Heat Demand (AHD contacts are closed and wired to the heat pump thermostat input; DHW calls are handled by the boiler's 2nd AHD contact wired to the heat pump DHW input.

Operation can be configured for systems that are limited by the heat pump capacity or supply temperature.

- Systems limited by heat pump capacity will have significant concurrent boiler and heat pump operation and the heat pump should be installed upstream of the boiler to prevent the heat pump return temperatures from rising too high.
- Systems limited by heat pump supply temperature will have little to no concurrent boiler and heat pump operation and the heat pump may be installed upstream or downstream of the boiler.

Circulator control:

- The ECO HP will control its own circulator
- The WM Unity 2.0 boiler or additional zone board will control all other circulators.

*Combi models use Input/Output pairs 1 and 4 for 3-way valve operation and cannot be used for any other purpose.

NOTE: Unity 2.0 boilers will begin supporting System Type A in early 2025.

System Type (continued)

System Type B: WM Heat Pump & any Boiler with a Thermostat Input

Figure 4 System Type B - Eco™HP (Master); Boiler (Shadow)

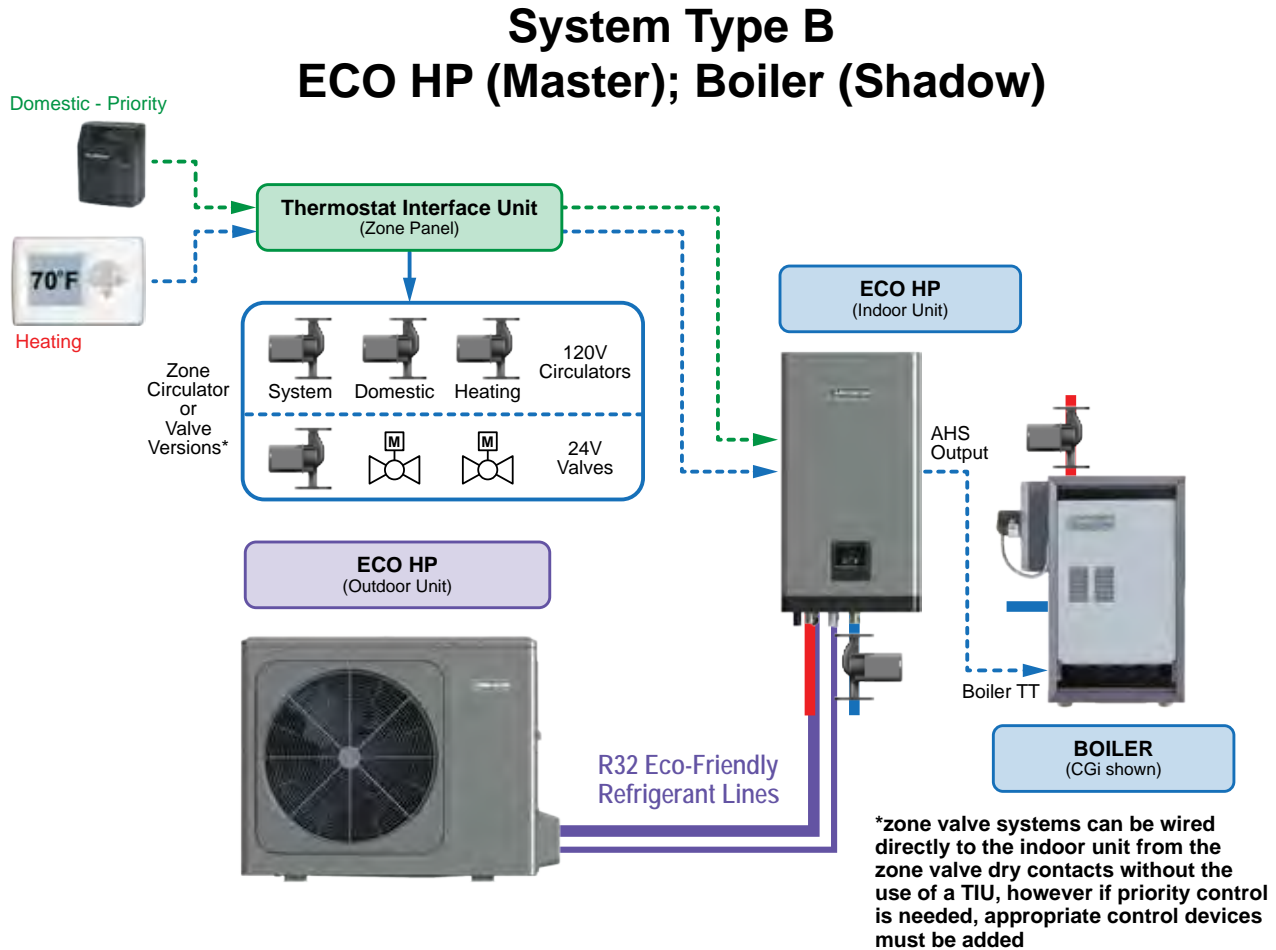

Type B systems use the ECO HP as master. The ECO HP will determine when the heat pump will run and when the boiler will run. Only 1 zone is supported natively, but additional zones can be used with an appropriate zone panel such as the TIU detailed on [page 18](#).

The system call for heat or DHW will pass through a Thermostat Interface Unit (TIU) or zone panel. This call is transferred via the TIU end switches to the appropriate HP inputs. The ECO HP can only connect directly to dry contacts that are rated for 12Vdc. The boiler will receive its call for heat or DHW when the heat pump's Additional Heat Source (AHS) dry contacts are closed.

NOTE: If priority operation of circulators or zone valves is desired, a TIU or zone panel with priority functionality must be used.

Operation can be configured for systems that are limited by the heat pump capacity or supply temperature.

- Systems limited by heat pump capacity will have significant concurrent boiler and heat pump operation and the heat pump should be installed upstream of the boiler to prevent the heat pump return temperatures from rising too high.
- Systems limited by heat pump supply temperature will have little to no concurrent boiler and heat pump operation and the heat pump may be installed upstream or downstream of the boiler. If the boiler is direct piped into the system and supplies high water temperatures, the heat pump will likely not be able to operate concurrently if the boiler is upstream of the heat pump due to heat pump temperatures rising too high.

Circulator control:

- The ECO HP will control its own circulator and may control one space heat zone circulator.
- A TIU or zone panel will control all other circulators.

System Type (continued)

System Type C: HP Only and Multi-HP

Figure 5 System Type C - Eco™HP Solo

**System Type C
ECO HP Solo**

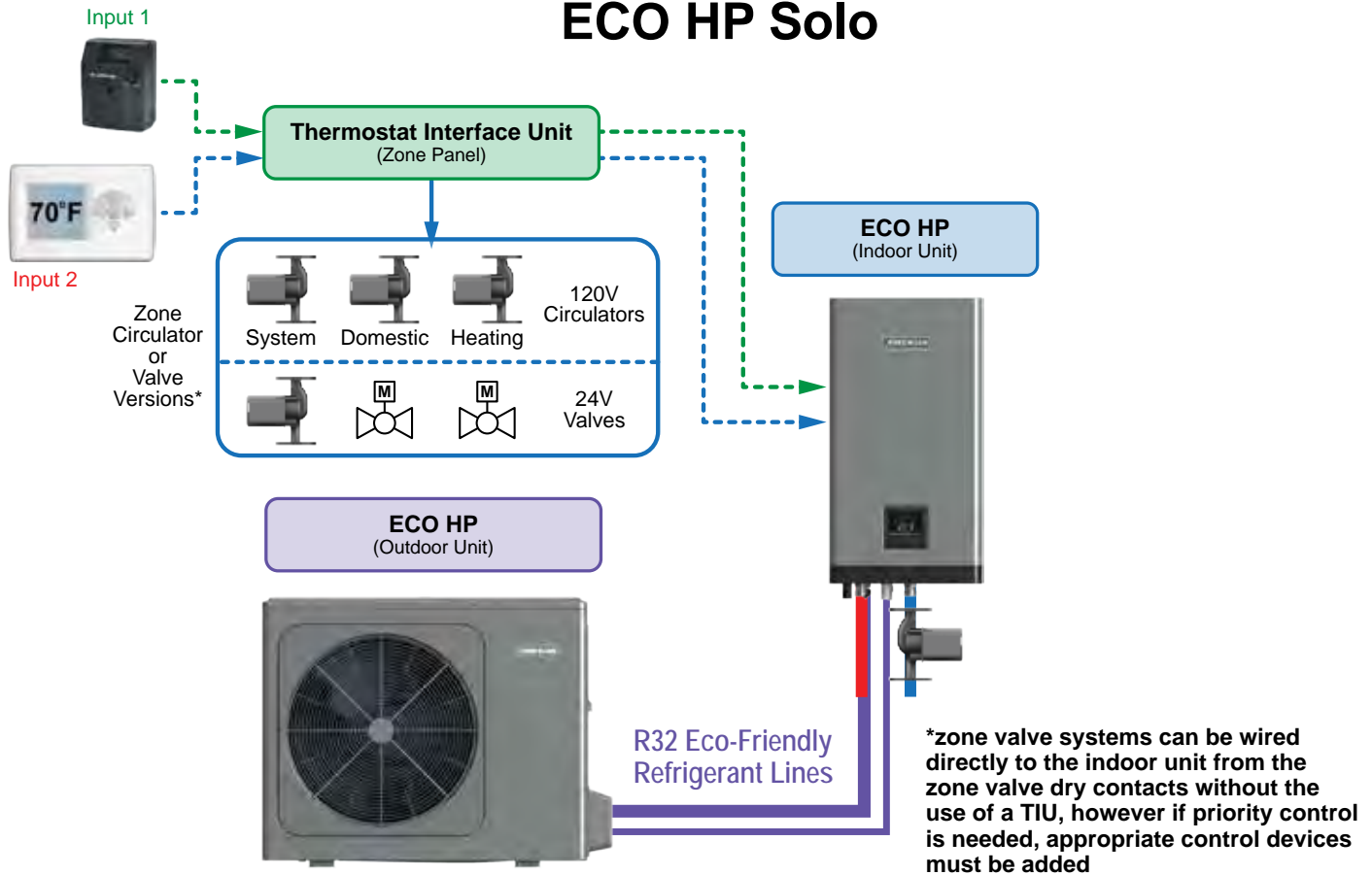

Type C Systems use only the ECO HP, without any other additional heat sources. Only 1 zone is supported natively, but additional zones can be used with an appropriate zone panel such as the TIU detailed on [page 18](#)

The system call for heat or DHW will pass through a Thermostat Interface Unit (TIU) or zone panel. This call is transferred via the TIU end switches to the appropriate HP inputs. The ECO HP can only connect directly to dry contacts that are rate for 12Vdc.

NOTE: If priority operation of circulators or zone valves is desired, a TIU or zone panel with priority functionality must be used.

Circulator control:

- The ECO HP will control its own circulator and may control one space heat zone circulator.
- A TIU or zone panel will control all other circulators.

General Control Settings (HP, Boiler, TIU)

The WM ECOCalc tool will calculate the outdoor reset curves for finned tube baseboard applications based on the following inputs:

- Manual J heat loss values
- Boiler type (Unity 2.0 controlled boiler OR other)
- Location
- Emitter type/quantity.
- Zones
- System fluid (water or glycol mix)
- Piping
- Circulators

Contact Weil-McLain for access to this tool as well as sizing and application support.

The outdoor reset curves will including the following temperatures:

- maximum water flow temperature
- minimum water flow temperature
- outdoor temperature at maximum flow temperature
- outdoor temperature at minimum flow temperature
- balance point temperature

For radiant flooring systems, the unit water minimum and maximum flow temperatures should be set per the flooring design.

For emitter types other than finned tube baseboard, refer to manufacturer's documentation for minimum and maximum flow temperatures.

Notes:

- Be sure to record ECOCalc values in the provided form at the end of this guide for future reference.
- ECOCalc will be available in 2025, contact Weil-McLain for sizing and application support.

General Control Settings (HP, Boiler, TIU) (continued)

Figure 6 Home Screen



Weather Temp Set (Outdoor Reset)

Figure 7 Temp. Settings

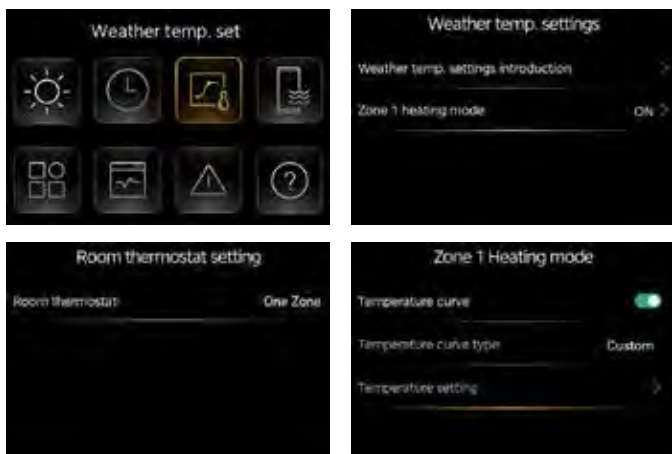

The target water temperature can be regulated automatically dependent on the outdoor ambient temperature. This function only applies to space heating, not DHW.

The temperature curve type must be set to custom. The variables T1SetH1 (Max Target Temp), T1SetH2 (Min Target Temp), T4H1 (Outdoor Temp for Max Target), and T4H2 (Outdoor Temp for Min Target) must be set as determined by the ECOCalc Tool.

FOR SERVICEMAN Mode

Figure 8 Entering serviceman menu

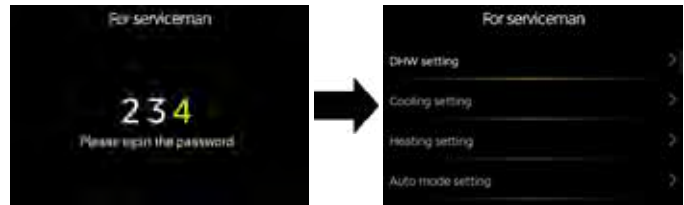

Press and hold 'Menu' (≡) and 'Rightward' (>) simultaneously for 3 seconds to enter the authorization page. Enter password **234** and press 'Confirm' (O) to confirm it. The display will then list the advanced settings of the unit.

Only qualified service personnel should adjust settings in the FOR SERVICEMAN mode

Save Settings and Quit FOR SERVICEMAN Mode

Figure 9 Quitting for serviceman menu



After all settings are adjusted, press 'Menu' (≡), and select Yes to confirm settings and quit FOR SERVICEMAN mode. All settings are saved automatically after you quit FOR SERVICEMAN mode.

General Control Settings (HP, Boiler, TIU) (continued)

Table 1 Heating Setting menu parameters

Code	State	Default	Minimum	Maximum	Set Interval	Unit
Heating Mode*	Enable or Disable the heating mode. 0=NO, 1=YES	1	0	1	1	/
t_T4_Fresh_H	The refresh time of climate related curves in heating mode	0.5	0.5	6	0.5	Hrs
T4HMAX*	The maximum ambient operating temperature in heating mode.	77	68	95	1	F
T4HMIN*	The minimum ambient operating temperature in heating mode.	5	-13	86	1	F
dT1SH (NOTE 1)	The temperature difference for starting the unit (T1)	9	4	36	1	F
dTSH	N/A	4	2	18	1	F
Zone 1 H-emission	The type of Zone 1 terminal for heating mode: 0=FLH (floor heating) 1=FCU (fan coil unit), 2=RAD (radiator)	2	0	2	1	/
Force defrost	Enable or disable the force defrost: 0=NO, 1=YES.	0	0	1	1	/

*settings must be applied per ECOCalc. Heating mode must be set to YES or heat pump will not operate. See Applications section starting on [page 20](#) for details.

Note: If Zone 1 H-emission is set to FCU or RAD, the selectable target temperature range will be between 95°F and 149°F. If set to FLH, the range will be between 77°F and 131°F.

Heating Setting

Figure 10 Heat Setting



Temp Type Settings

Figure 11 Temp. Type Setting

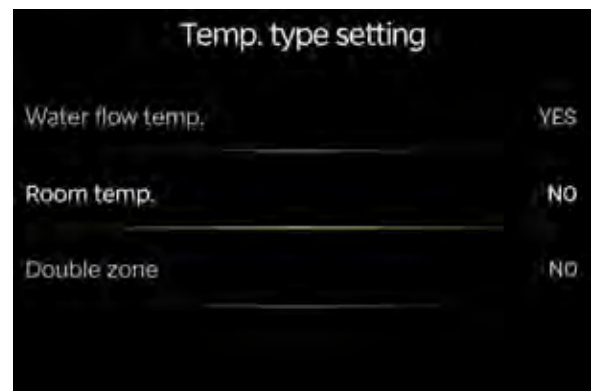

NOTE:

dT1SH is the on and off temperature differential. If the target temp minus dT1SH is greater than 125.6°F, then the unit will switch on once supply temperature (Twout) has dropped below 125.6°F, NOT target temp – dT1SH. Similarly, if the target temperature plus dT1SH is greater than T1STOPH+1, then the unit will shut off when supply temperature (Twout) is greater than T1STOPH+1, not target temp + dT1SH.

† T1STOPH is the maximum high temperature limit, values may be between 113°F and 149°F, depending on outdoor temperature (T4)

Code	State	Default	Minimum	Maximum	Set Interval	Unit
Water flow temp.	Enable or disable the water flow temp. 0=NO, 1=YES	1	0	1	1	/
Room temp.	Enable or disable the room temp. 0=NO, 1=YES	0	0	1	1	/
Double zone*	Enable or disable the double zone. 0=NO, 1=YES	0	0	1	1	/

*Double zone should always be set to no. If Room thermostat is set to One Zone, then double zone will automatically be set to NO.



General Control Settings (HP, Boiler, TIU) (continued)

Room Thermostat

Figure 12 Room Thermostat Setting

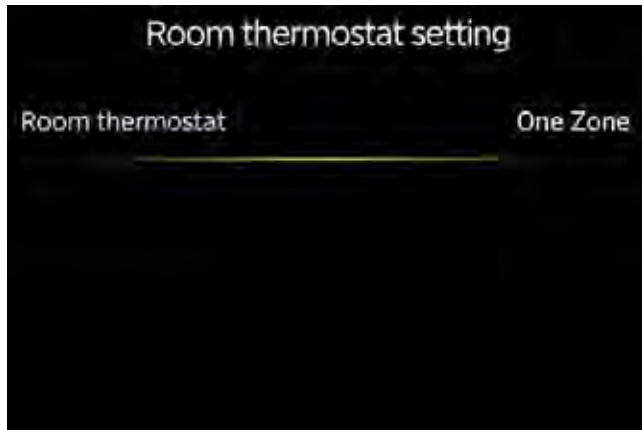

Inputs may be paired with dry contacts only. 24Vac Thermostats require using the provided Thermostat Interface Unit or a control device with end switches rated for 12Vdc.

Room Thermostat provides 12Vdc on the R terminal:

- a. When the unit detects a voltage of 12Vdc between W and R (circuit is closed), unit turns on.
- b. When the unit detects a voltage of 0Vdc between W and R (circuit is open), unit turns off.

Code	State	Default	Minimum	Maximum	Set Interval	Unit
Room thermostat*	The style of room thermostat: 0=NO, 1=Mode set, 2=One zone, 3=Double zone	0	0	3	1	/
Mode set priority	Select the priority mode in room thermostat: 0=Heating, 1=Cooling	0	0	1	1	/

*must be set to One zone, all other options are not applicable.

Other Heat Source

Figure 13 Heating and DHW

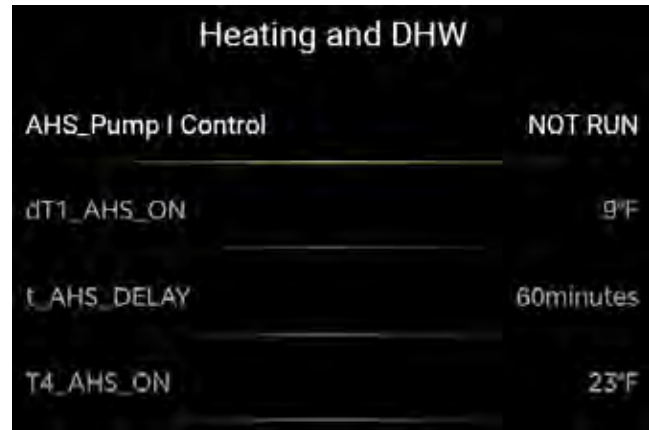

Code	State	Default	Minimum	Maximum	Set Interval	Unit
AHS function*	Enable or disable the AHS (Auxiliary heating source) function: 0=NO, 1=Heating, 2=Heating and DHW	0	0	2	1	/
AHS_PUMP_I Control	Select the pump operating status when only AHS runs: 0=RUN, 1=Not run	0	0	1	1	/
dT1_AHS_ON	The temperature difference between T1S (Target Temp) and T1 (Supply Temp) for activating the AHS	9	4	36	1	F
t_AHS_DELAY	A time delay for activating AHS. When T4 (outdoor temp) is less than T4_AHS_ON, then the HP will continue to run for the time t_AHS_DELAY is set to before enabling the AHS output	30	5	120	5	Minutes
T4_AHS_ON*	The ambient temperature below which the AHS will be activated	23	5	86	1	F

*settings must be applied per ECOCalc. AHS function must be enabled for Type B (HP is master) installations.

DHW Function

There are no adjustable DHW settings on the Eco™HP control. When the EVU contacts are closed, the Eco™HP will run in DHW mode. This mode targets the highest outlet water temperature the Eco™HP can attain and takes priority over a heating call. This call will run until satisfied and the call is removed. In type A systems, the Max On Time can be adjusted in the Unity 2.0 control and the DHW call will be limited to that time before allowing a heating priority to run. In type B and C systems, the TIU has a fixed 1 hour timer which when expired, will allow heating zones to run.

General Control Settings (HP, Boiler, TIU) (continued)

Heat Pump Control Schematic

Figure 14 Heat Pump Control Schematic

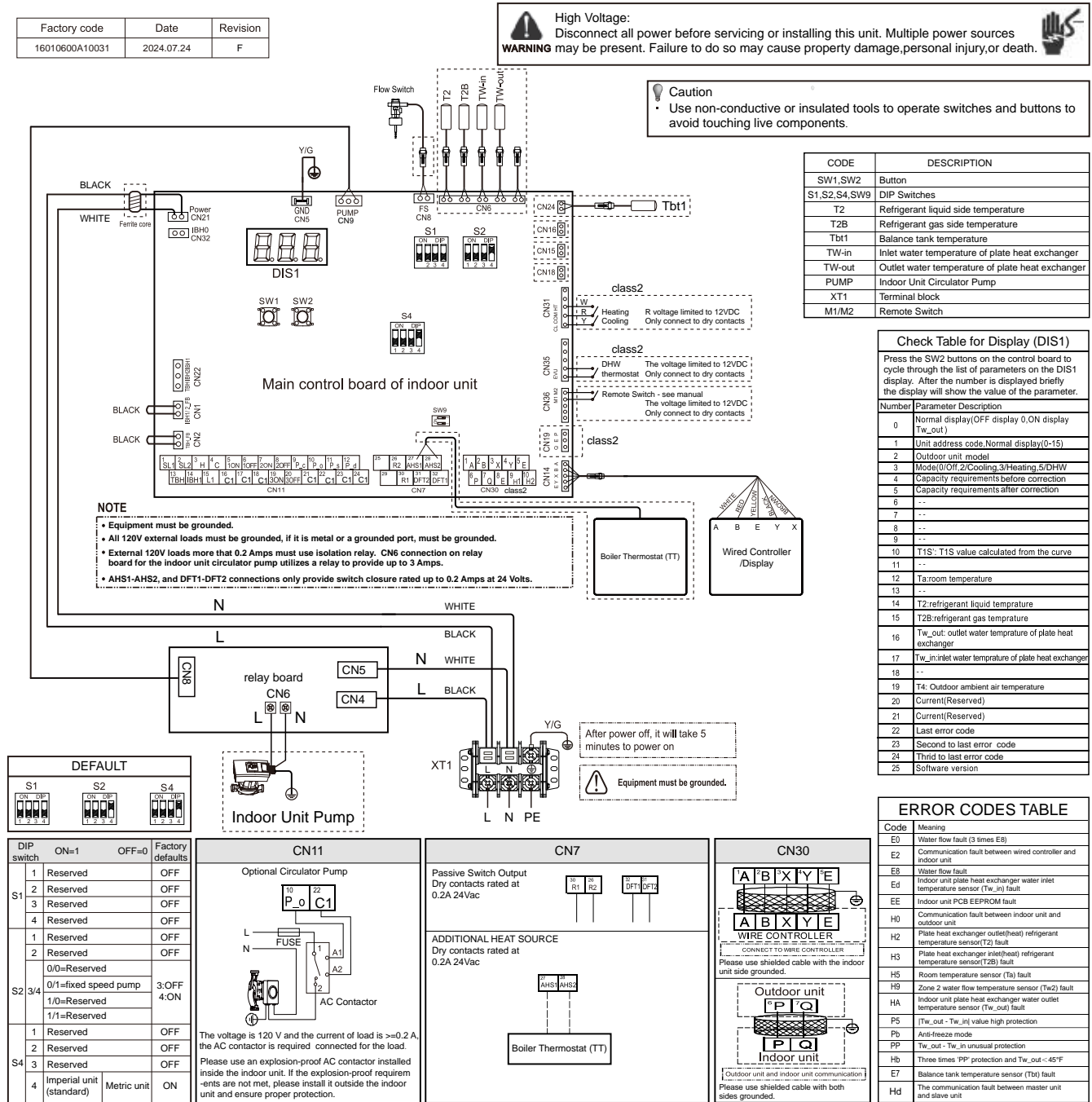

NOTE: This schematic can also be found on the IDU control box cover panel inside face.

General Control Settings (HP, Boiler, TIU) (continued)

Unity 2.0 AHD

The WM Unity 2.0 control allows for two methods of switching heat pump and boiler operation, ODT and Target Temp mode.

AHD ODT Mode

A user-defined ODT SETPOINT is used as switching point to operate the Additional Heat Demand as defined by the user settings for ACTIVATE CONTACT ABOVE SETPOINT and ACTIVATE CONTACT BELOW SETPOINT.

The outdoor temperature is compared to the ODT SETPOINT. If the outdoor temperature is less than the ODT SETPOINT, AHD will operate based on ACTIVE CONTACT BELOW SETPOINT settings and if outdoor temperature is greater than ODT SETPOINT, AHD will operate based on ACTIVE CONTACT ABOVE SETPOINT.

For hybrid systems, ACTIVATE CONTACT ABOVE SETPOINT should be set to 1ST and ACTIVATE CONTACT BELOW SETPOINT should be set to 1ST or EMERGENCY. This will ensure the HP will not operate below the minimum outdoor temperature determined by ECOCalc.

AHD ODT mode is recommended for systems limited by the heat pump capacity. Since heat pump capacity is a function of outdoor temperature, AHD ODT mode can ensure the heating system capacity is sufficient for the need by activating the boiler when heat pump capacity drops below the required amount calculated by the reset curve.

AHD Target Temp Mode

A user-defined TARGET CROSSOVER TEMP is used as a switching point to operate Additional Heat Demand as defined by the user settings for ACTIVATE CONTACT BELOW CROSSOVER and ACTIVATE CONTACT ABOVE CROSSOVER. The priority's calculated Target Temp (based on that priority's Outdoor Reset Curve) is compared to the TARGET CROSSOVER TEMP. If Target Temp is less than TARGET CROSSOVER TEMP, AHD order will operate based on ACTIVATE CONTACT BELOW CROSSOVER, and if Target is greater than TARGET CROSSOVER TEMP, AHD order will operate based on ACTIVATE CONTACT ABOVE CROSSOVER.

For Hybrid systems, ACTIVATE CONTACT ABOVE CROSSOVER should be set to OFF or EMERGENCY and ACTIVATE CONTACT BELOW CROSSOVER should be set to 1ST. This will ensure the Boiler operates at higher target temperatures and the HP operates at lower target temperatures as determined by the outdoor reset curve generated by ECOCalc.

AHD Target Temp mode is recommended for systems limited by the heat pump maximum supply temperature. Since heat pump maximum supply temperature is a function of outdoor temperature, AHD Target temp mode can ensure the heating system supply temperature is sufficient for the need by activating the boiler when the heat pump maximum supply temperature drops below required amount calculated by the reset curve.

Thermostat Interface Unit (TIU)

The Thermostat Interface Unit is a zone panel that allows the usage of standard 24V thermostats with the WM ECO HP. Weil-Mclain offers a zone valve TIU (Taco ZVC404-5) and a zone circulator TIU (Taco SR503-5).

By default, the TIU will operate the main end switch output and priority end switch output whenever there is a priority call. This can be changed in the Taco Control app. The Main Boiler End Switch should be changed from default to Activate on Zone 2 only. If not changed, the ECO HP display will show a space heat call even when there is none during a DHW call. This will not affect proper operation, only the indication on the screen.

Figure 15 TIU screens

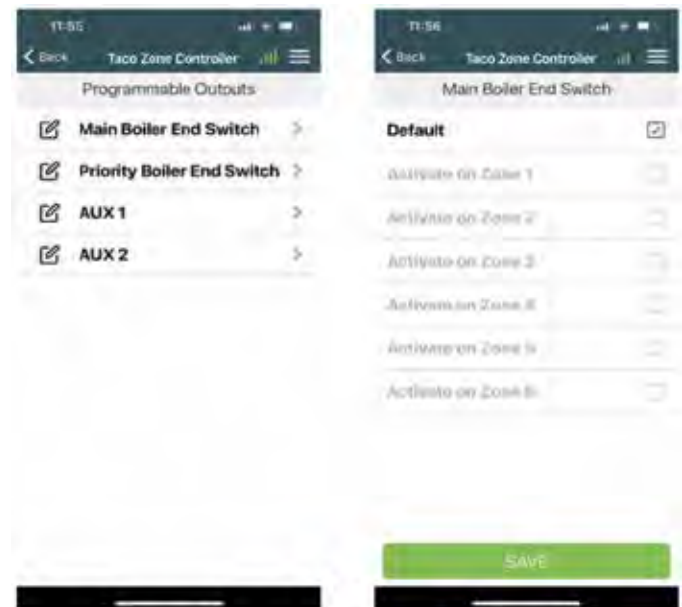

Programmable Outputs: Change relay outputs behavior to each unique application. A custom name can also be added to identify output action.

Main Boiler End Switch: Change the behavior or action of the Main Boiler End Switch relay output.



SECTION 3

Applications

This page intentionally left blank.



System Type A

Application A1: Multi-zone space heating, DHW as zone

If boiler will run concurrently with the heat pump, boiler must be downstream from heat pump to prevent high return water temperatures.

Overview

- Three zones for space heating, zoned with circulators, through the WM Unity 2.0 controlled boiler.
- One zone for DHW, zoned with a circulator, through the WM Unity 2.0 controlled boiler.
- DHW Priority – space heating is disabled during call for heat from DHW indirect tank.

Unity 2.0 Control Settings

- See table on [page 24](#) for boiler control settings.
- Refer to the boiler manual for specific control navigation information.

ECO HP Control Settings

- See table on [page 25](#) for heat pump control settings.
- Refer to [page 14](#) for heat pump control navigation information.

Circulators and piping

- Piping must be primary/secondary.
- If boiler will run concurrently with the ECO HP, the boiler must be downstream from ECO HP to prevent high return temperatures from shutting down the heat pump.
- DHW circulator must be selected to handle the pressure drop through the indirect tank and piping.
- For some large indirect water heaters, the required flow rate may require piping the water heater differently.
- Zone circulators should be sized for required flow.
- Space heating zone circulators and DHW zone circulator provided by installer.
- For alternate wiring using a zone panel like the TIU.
- Boiler circulator is installed internally within the boiler.
- Heat Pump circulator is installed in heat pump manifold and included in the heat pump accessory box.

If only one AHD output is available:

- Operate DHW through boiler only (see Application A2, [page 26](#))

OR

- Set reset curves to ensure sufficient DHW temperatures (minimum supply temperature 130°F). This will reduce heat pump run time as boiler will run more frequently at higher outdoor temps.

System Type A (continued)

Application A1: Multi-zone space heating, DHW as zone (continued)

Application Piping

Legend

- | | | | |
|---|--|--|---|
| <ul style="list-style-type: none"> 1. ■ Boiler. 2. Indirect water heater, if used (domestic water piping not shown). 3. ■ Relief valve, supplied with boiler and heat pump, field piped. 4. Relief valve piping to drain. 5. DHW circulator. 6. Isolation valves. | <ul style="list-style-type: none"> 7. ■ Y-Strainer with 80 mesh screen. 8. Expansion tank. 9. Air separator. 10. Flow/check or spring check valves. 11. Purge/drain valves. 12. ■ Heat pump circulator. 13. Heat trap. 14. Unions as needed for service. | <ul style="list-style-type: none"> 15. Return temperature sensor. 16. Supply temperature sensor. 17. ■ Eco™ HP Heat Pump 20. Make-up water supply. 23. DHW Temperature and Pressure relief valve 24. Zone circulators. 25. ■ Boiler or heat pump drain valve, supplied with boiler or heat pump, field piped. | <ul style="list-style-type: none"> 26. Zone Valves. 27. Bypass pressure regulator 30. ■ Pressure/temperature gauge, supplied with boiler and heat pump, field piped. <p>■ = Items supplied with boiler or heat pump - all other Items supplied by installer.</p> |
|---|--|--|---|

Figure 16 Application A1: Multi-zone space heating, DHW as zone Application Piping

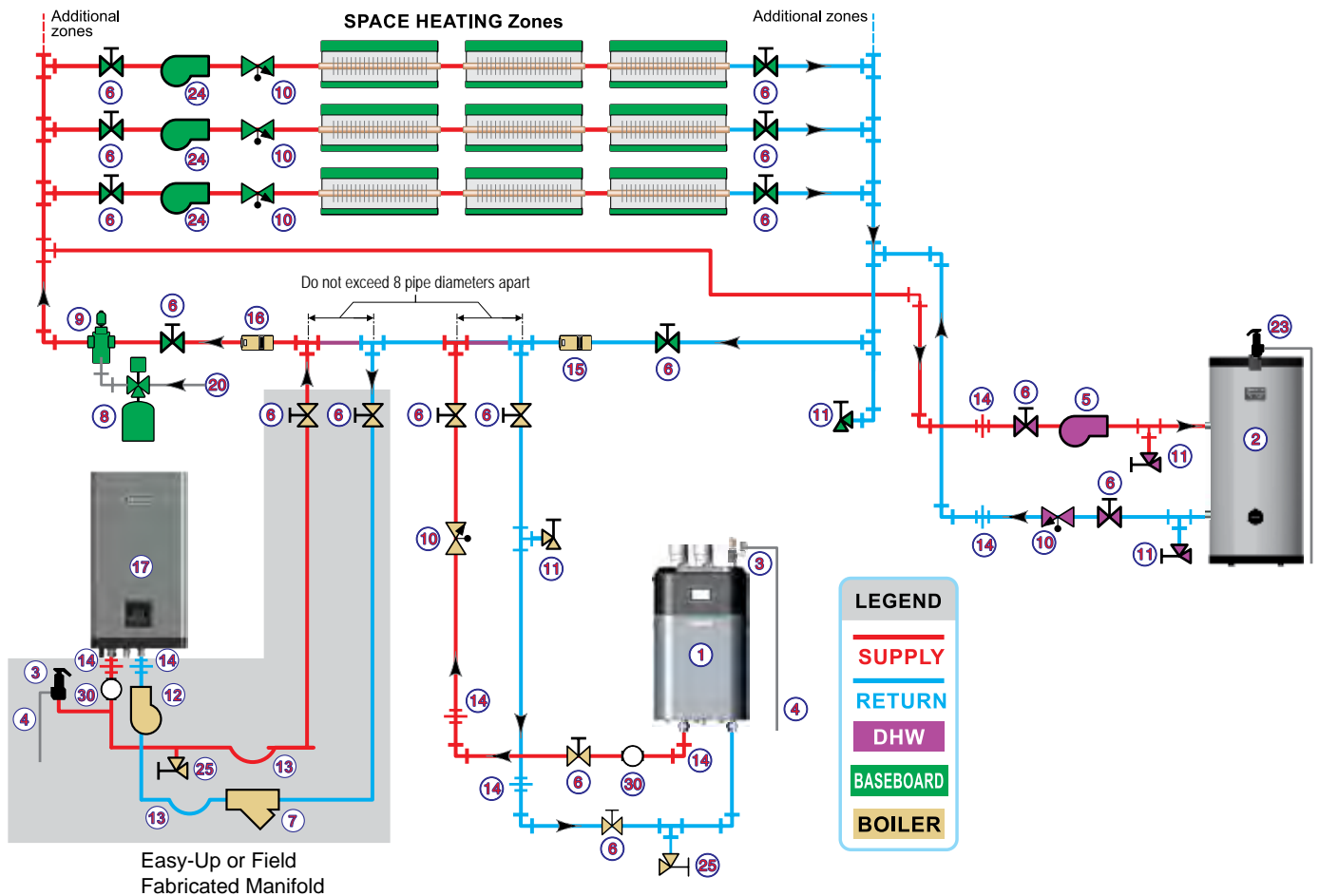

System Type A (continued)

Application A1: Multi-zone space heating, DHW as zone (continued)

Application Wiring

Figure 17 Application A1: Multi-zone space heating, DHW as zone Application Wiring

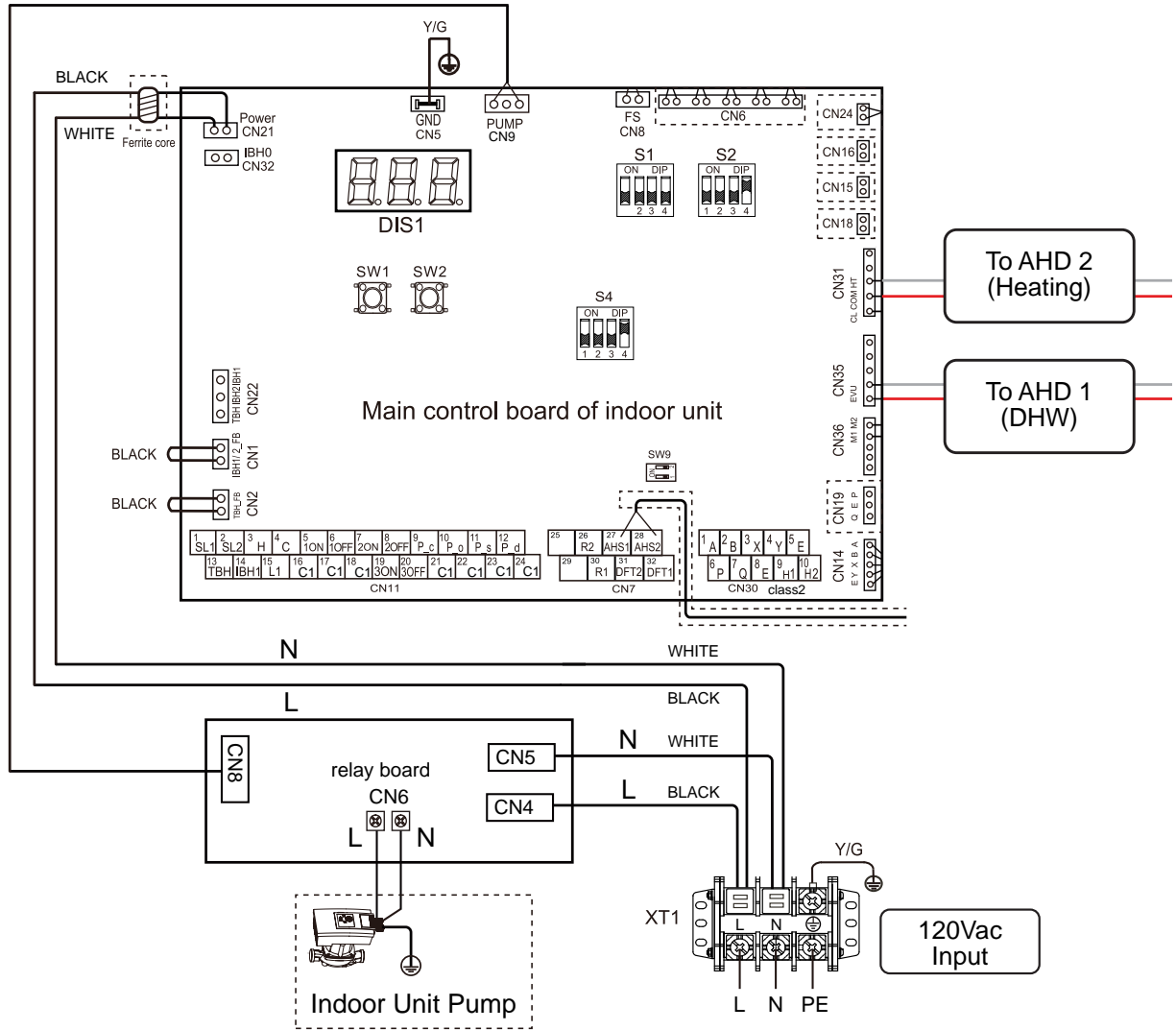

3



System Type A (continued)

Application A1: Multi-zone space heating, DHW as zone (continued)

Application Wiring (continued)

Figure 18 Application A1: Multi-zone space heating, DHW as zone Application Wiring

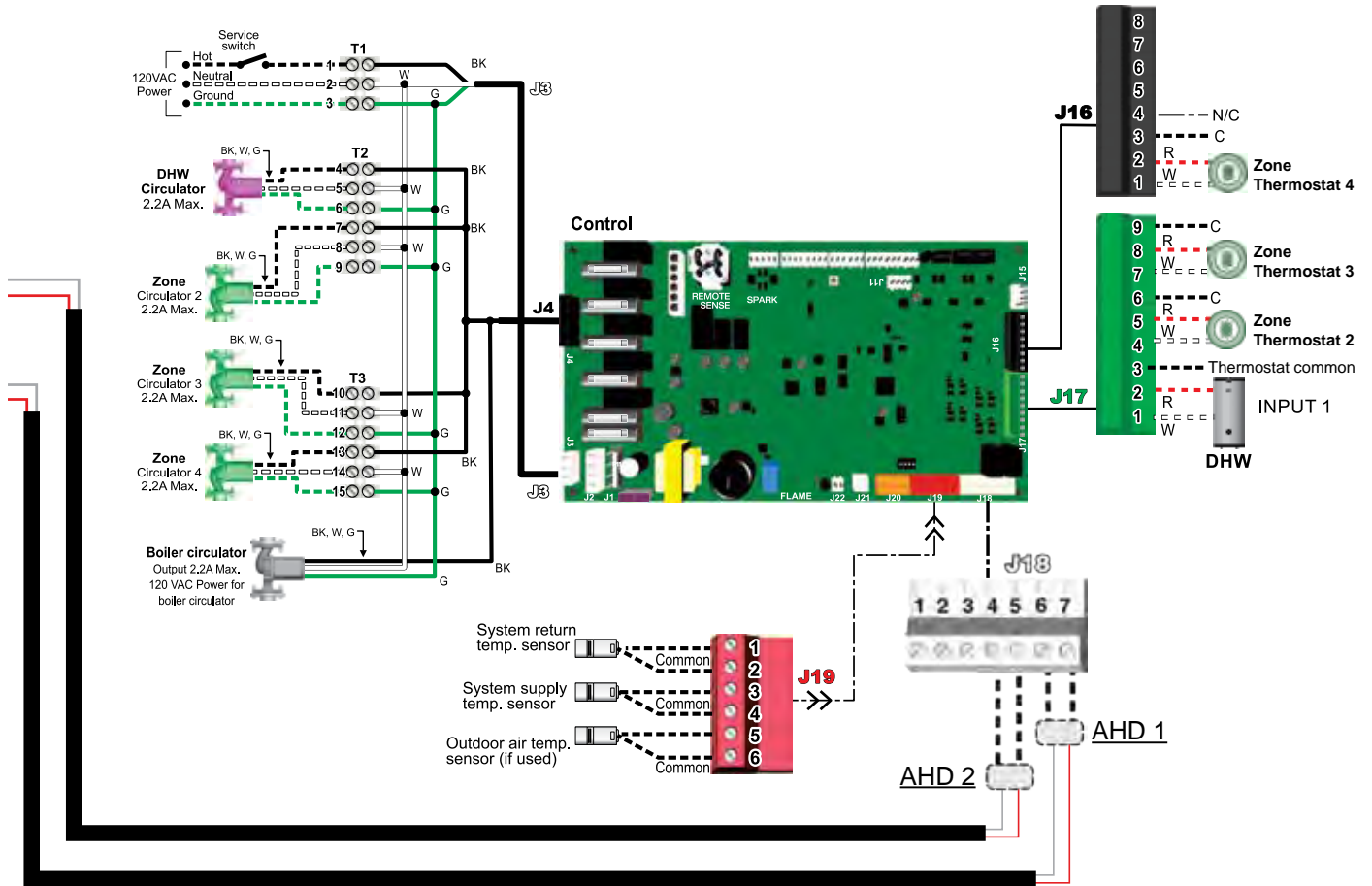

3



System Type A (continued)

Application A1: Multi-zone space heating, DHW as zone (continued)

Control Settings

Boiler (Master) Configuration

After entering the contractor menu, ensure the settings in the following sub-menus are set as noted.

System Settings

INPUT/OUTPUT 1

Name	"DHW" or as desired
Usage	Heat Demand
Priority	Priority 1

Priority 1

System Type	Domestic Hot Water
Target Modulation Sensor	System Supply
Target Adjust	N/A
Max Target Temp	Per ECOCalc
Min Target Temp	N/A
Outdoor Temp for Max Target	N/A
Outdoor Temp for Min Target	N/A
Max On Time	Default
Min On Time	N/A
Run Boiler Pump	Yes
AHD Assign Contact	1
AHD Priority	Outdoor Temp
System Temp Dependent	Yes
ODT Setpoint	Per ECOCalc
Activate Contact Below Setpoint	1ST
Activate Contact Above Setpoint	1ST

INPUT/OUTPUT 3

If Priority 2 is assigned, no further steps are required. If Priority 3 is assigned, repeat the steps from Input/output 2 above

INPUT/OUTPUT 2

Name	"Space Heat" or as desired
Usage	Heat Demand
Priority	Priority 2

Priority 2

System Type	Fin Base
Target Modulation Sensor	System Supply
Target Adjust	Outdoor Temp
Max Target Temp	Per ECOCalc
Min Target Temp	Per ECOCalc
Outdoor Temp for Max Target	Per ECOCalc
Outdoor Temp for Min Target	Per ECOCalc
Max On Time	Default
Min On Time	Default
Run Boiler Pump	Yes
AHD Assign Contact	2
AHD Priority	Outdoor Temp
System Temp Dependent	Yes
ODT Setpoint	Per ECOCalc
Activate Contact Below Setpoint	1ST
Activate Contact Above Setpoint	OFF

INPUT/OUTPUT 4

If Priority 2 is assigned, no further steps are required. If Priority 3 is assigned, repeat the steps from Input/output 2 above

3



System Type A (continued)

Application A1: Multi-zone space heating, DHW as zone (continued)

Control Settings (continued)

HP (Shadow) Configuration
See pg XX-YY for basic settings and navigation

Weather Temp. Settings

T1SetH1	Per ECOCalc
T1SetH2	Per ECOCalc
T4H1	Per ECOCalc
T4H2	Per ECOCalc

Heating Settings

T4HMAX	Per ECOCalc
T4HMIN	Per ECOCalc



System Type A (continued)

Application A2: Multi-zone Space Heating, Boiler only DHW

Overview

- Two zones for space heating, zoned with circulators, through the WM Unity 2.0 controlled boiler.
- DHW provided by ECO Tec Combi.
- DHW Priority – space heating is disabled during DHW combi call.

Unity 2.0 Control Settings

- See table on [page 30](#) for boiler control settings.
- Refer to the boiler manual for specific control navigation information.

ECO HP Control Settings

- See table on [page 31](#) for heat pump control settings.
- Refer to [page 14](#) for heat pump control navigation information.

Circulators and piping

- Piping must be primary/secondary.
- If boiler will run concurrently with the ECO HP, the boiler must be downstream from ECO HP to prevent high return temperatures from shutting down the heat pump.
- A mixing valve should be used to ensure supplied DHW temperatures are properly limited.
- Zone circulators should be sized for required flow.
- Space heating zone circulators and DHW zone circulator provided by installer.
- For alternate wiring using a zone panel like the TIU.
- Boiler circulator is installed internally within the boiler.
- Heat Pump circulator is installed in heat pump manifold and included in the heat pump accessory box.



System Type A (continued)

Application A2: Multi-zone Space Heating, Boiler only DHW (continued)

Application Piping

Legend

- | | | | |
|---|--|--|---|
| <ul style="list-style-type: none"> 1. ■ Boiler. 2. Indirect water heater, if used (domestic water piping not shown). 3. ■ Relief valve, supplied with boiler and heat pump, field piped. 4. Relief valve piping to drain. 5. DHW circulator. 6. Isolation valves. | <ul style="list-style-type: none"> 7. ■ Y-Strainer with 80 mesh screen. 8. Expansion tank. 9. Air separator. 10. Flow/check or spring check valves. 11. Purge/drain valves. 12. ■ Heat pump circulator. 13. Heat trap. 14. Unions as needed for service. | <ul style="list-style-type: none"> 15. Return temperature sensor. 16. Supply temperature sensor. 17. ■ Eco™ HP Heat Pump 20. Make-up water supply. 23. DHW Temperature and Pressure relief valve 24. Zone circulators. 25. ■ Boiler or heat pump drain valve, supplied with boiler or heat pump, field piped. | <ul style="list-style-type: none"> 26. Zone Valves. 27. Bypass pressure regulator 30. ■ Pressure/temperature gauge, supplied with boiler and heat pump, field piped. <p>■ = Items supplied with boiler or heat pump - all other Items supplied by installer.</p> |
|---|--|--|---|

Figure 19 Application A2: Multi-zone Space Heating, Boiler only DHW Application Piping

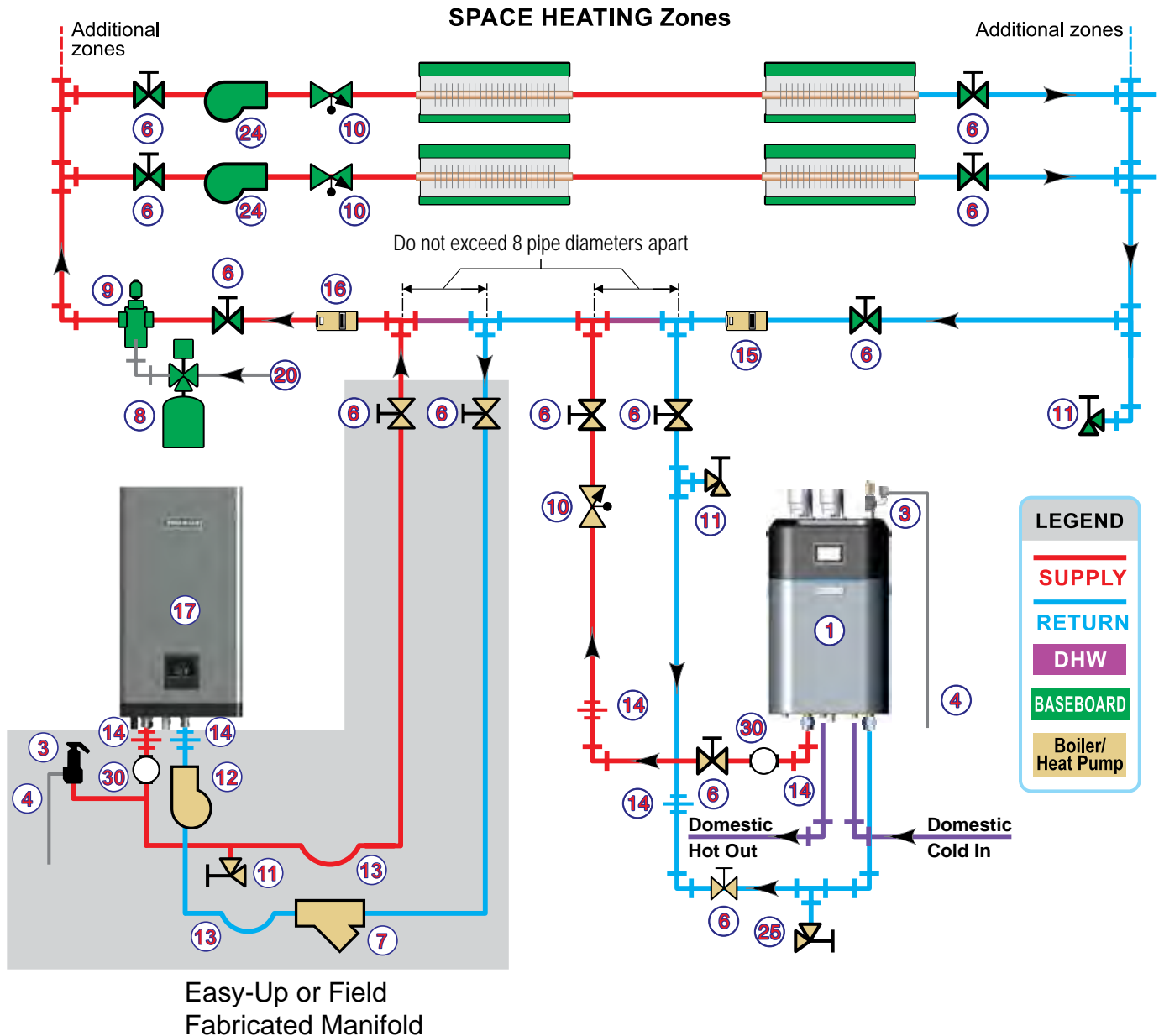

System Type A (continued)

Application A2: Multi-zone Space Heating, Boiler only DHW (continued)

Application Wiring

Figure 20 Application A2: Multi-zone Space Heating, Boiler only DHW Application Wiring

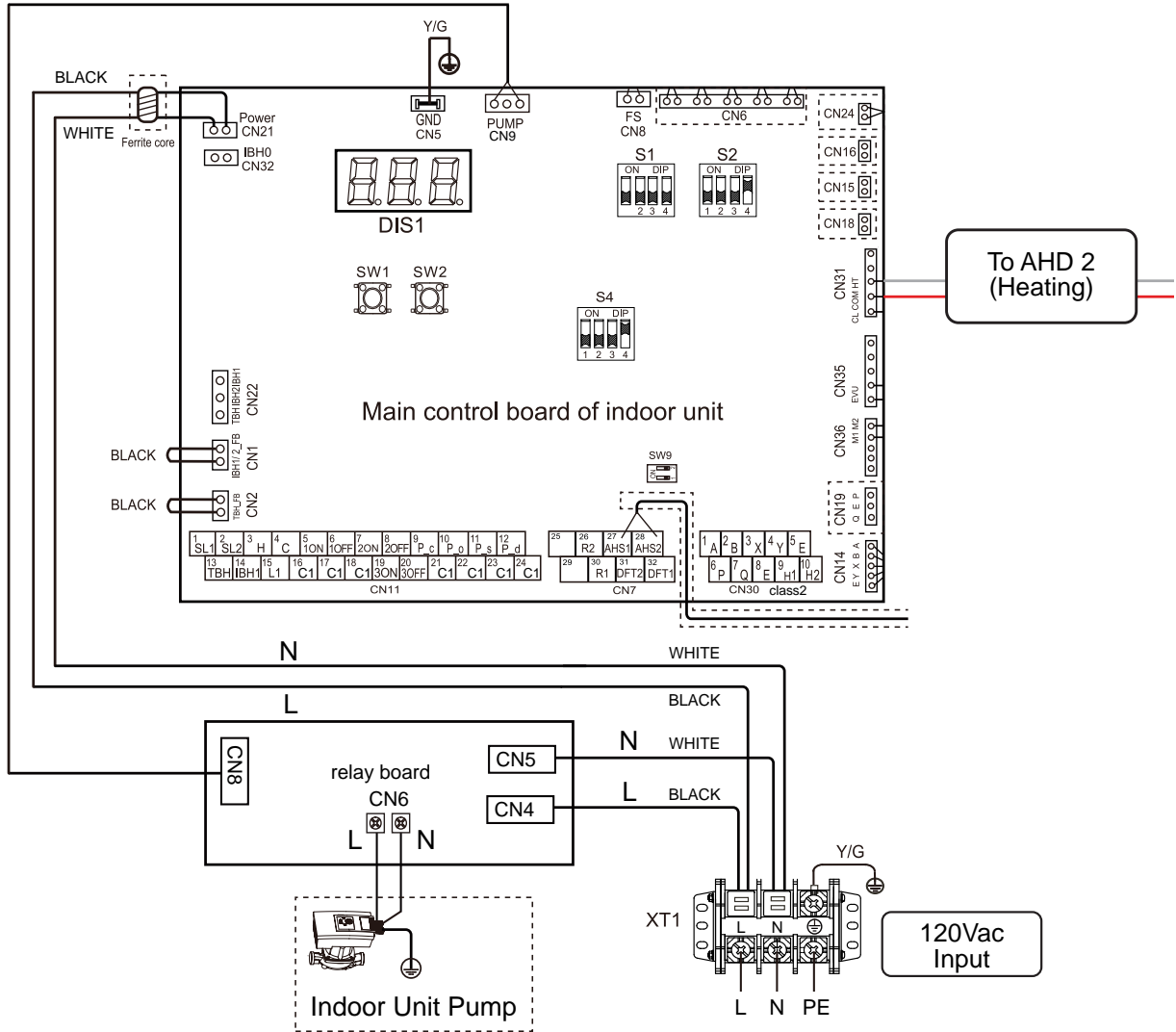

3

System Type A (continued)

Application A2: Multi-zone Space Heating, Boiler only DHW (continued)

Application Wiring (continued)

Figure 21 Application A2: Multi-zone Space Heating, Boiler only DHW Application Wiring

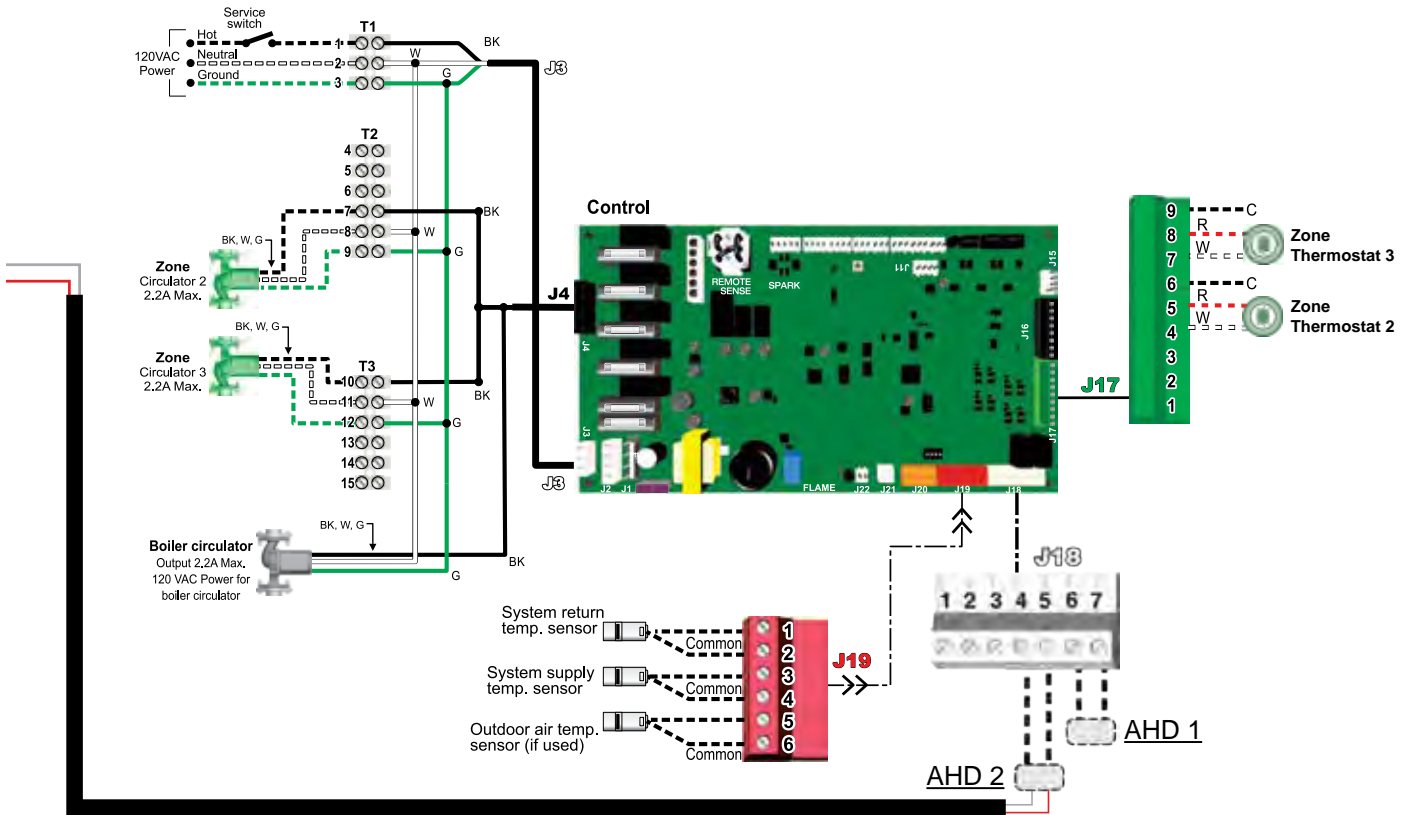



System Type A (continued)

Application A2: Multi-zone Space Heating, Boiler only DHW (continued)

Control Settings

Boiler (Master) Configuration

After entering the contractor menu, ensure the settings in the following sub-menus are set as noted.

System Settings

INPUT/OUTPUT 2

Name	"Zone 1" or as desired
Usage	Heat Demand
Priority	Priority 2

Priority 2

System Type	Fin Base
Target Modulation Sensor	System Supply
Target Adjust	Outdoor Temp
Max Target Temp	Per ECOCalc
Min Target Temp	Per ECOCalc
Outdoor Temp for Max Target	Per ECOCalc
Outdoor Temp for Min Target	Per ECOCalc
Max On Time	Default
Min On Time	N/A
Run Boiler Pump	Yes
AHD Assign Contact	2
AHD Priority	Outdoor Temp
System Temp Dependent	Yes
ODT Setpoint	Per ECOCalc
Activate Contact Below Setpoint	1ST
Activate Contact Above Setpoint	1ST

INPUT/OUTPUT 3

Name	"Zone 2" or as desired
Usage	Heat Demand
Priority	Priority 2

3



System Type A (continued)

Application A2: Multi-zone Space Heating, Boiler only DHW (continued)

Control Settings (continued)

HP (Shadow) Configuration
See pg XX-YY for basic settings and navigation

Weather Temp. Settings

T1SetH1	Per ECOCalc
T1SetH2	Per ECOCalc
T4H1	Per ECOCalc
T4H2	Per ECOCalc

Heating Settings

T4HMAX	Per ECOCalc
T4HMIN	Per ECOCalc



System Type B

Application B1: Multi-zone space heating DHW as zone, boiler direct piped

Overview

- Two zones for space heating, zoned with circulators, through the TIU.
- One zone for DHW, zoned with circulators, through the TIU.
- DHW Priority – space heating is disabled during DHW combi call.

Boiler Settings

- See table on [page 36](#) for boiler control settings.
- Refer to the boiler manual for specific control navigation information.

ECO HP Control Settings

- See table on [page 36](#) for heat pump control settings.
- Refer to [page 14](#) for heat pump control navigation information.

Circulators and piping

- Piping must be primary/secondary.
- If boiler will run concurrently with the ECO HP, the boiler must be downstream from ECO HP to prevent high return temperatures from shutting down the heat pump.
- A mixing valve should be used to ensure supplied DHW temperatures are properly limited.
- Zone circulators should be sized for required flow.
- Space heating zone circulators and DHW zone circulator provided by installer.
- Additional zones can be added with additional zone panels.
- Heat Pump circulator is installed in heat pump manifold and included in the heat pump accessory box.

This system will run a DHW call until it is satisfied. It will also run other zones after 1 hour of a DHW call, if other zone calls are present. However, the Target Temperature on the heat pump will remain T1STOPH (max temperature) until the DHW call is satisfied.

All zones should either run properly and safely at supply temperatures up to 149°F or using mixing valves to supply proper temperatures to zones.

Boiler is limited to one priority/reset curve. If reset curve is enabled, DHW supply temperatures will vary based on the curve. Ensure curve is sufficient for DHW operation. It is recommended to set a single boiler target temperature and not use the boiler reset curve if supply temperatures will drop below 130°F for a DHW call.

System Type B (continued)

Application B1: Multi-zone space heating DHW as zone, boiler direct piped (continued)

Application Piping

Legend

- | | | | |
|---|---|---|---|
| <ul style="list-style-type: none"> 1. ■ Boiler. 2. Indirect water heater, if used (domestic water piping not shown). 3. ■ Relief valve, supplied with boiler and heat pump, field piped. 4. Relief valve piping to drain. 5. DHW circulator. 6. Isolation valves. | <ul style="list-style-type: none"> 7. ■ Y-Strainer with 80 mesh screen. 8. Expansion tank. 9. Air separator. 10. Flow/check or spring check valves. 11. Purge/drain valves. 12. ■ Heat pump circulator. 13. Heat trap. | <ul style="list-style-type: none"> 14. Unions as needed for service. 17. ■ Eco™ HP Heat Pump 20. Make-up water supply. 23. DHW Temperature and Pressure relief valve 24. Zone circulators. 25. ■ Boiler or heat pump drain valve, supplied with boiler or heat pump, field piped. | <ul style="list-style-type: none"> 26. Zone Valves. 27. Bypass pressure regulator 30. ■ Pressure/temperature gauge, supplied with boiler and heat pump, field piped. <p>■ = Items supplied with boiler or heat pump - all other Items supplied by installer.</p> |
|---|---|---|---|

Figure 22 Application B1: Multi-zone space heating DHW as zone, boiler direct piped Application Piping

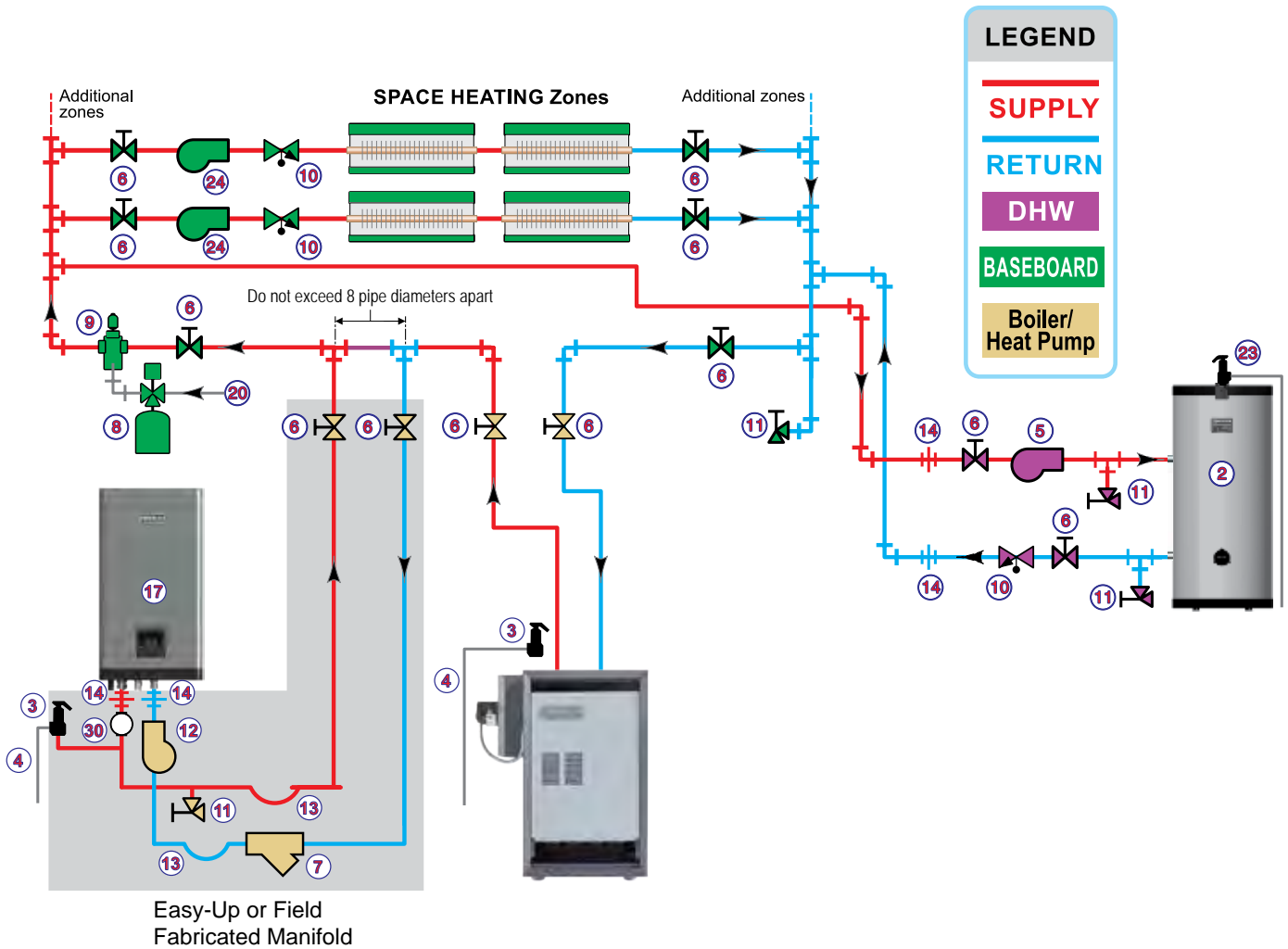

System Type B (continued)

Application B1: Multi-zone space heating DHW as zone, boiler direct piped (continued)

Application Wiring

Figure 23 Application B1: Multi-zone space heating DHW as zone, boiler direct piped Application Wiring

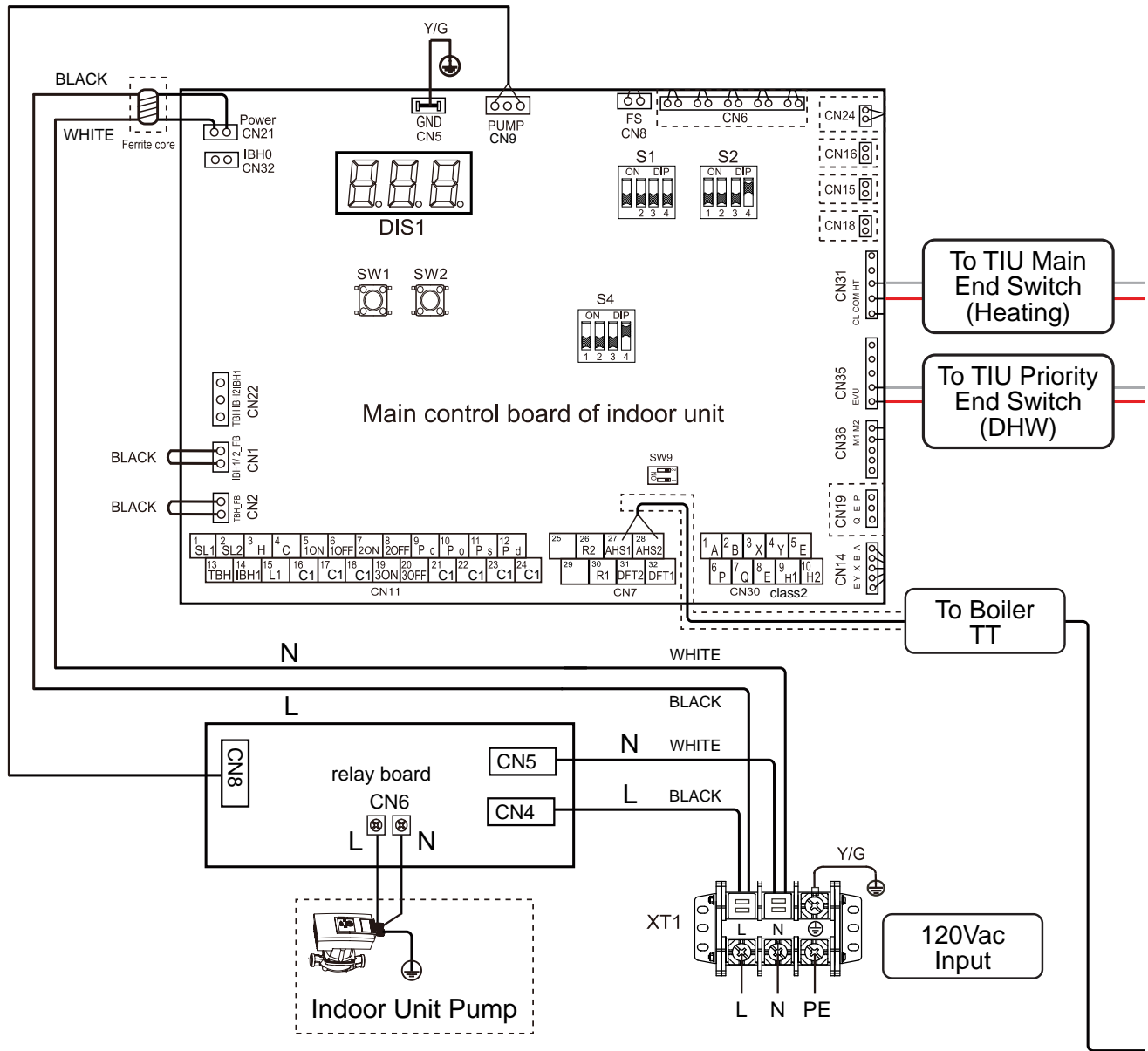

System Type B (continued)

Application B1: Multi-zone space heating DHW as zone, boiler direct piped (continued)

Application Wiring (continued)

Figure 24 Application B1: Multi-zone space heating DHW as zone, boiler direct piped Application Wiring

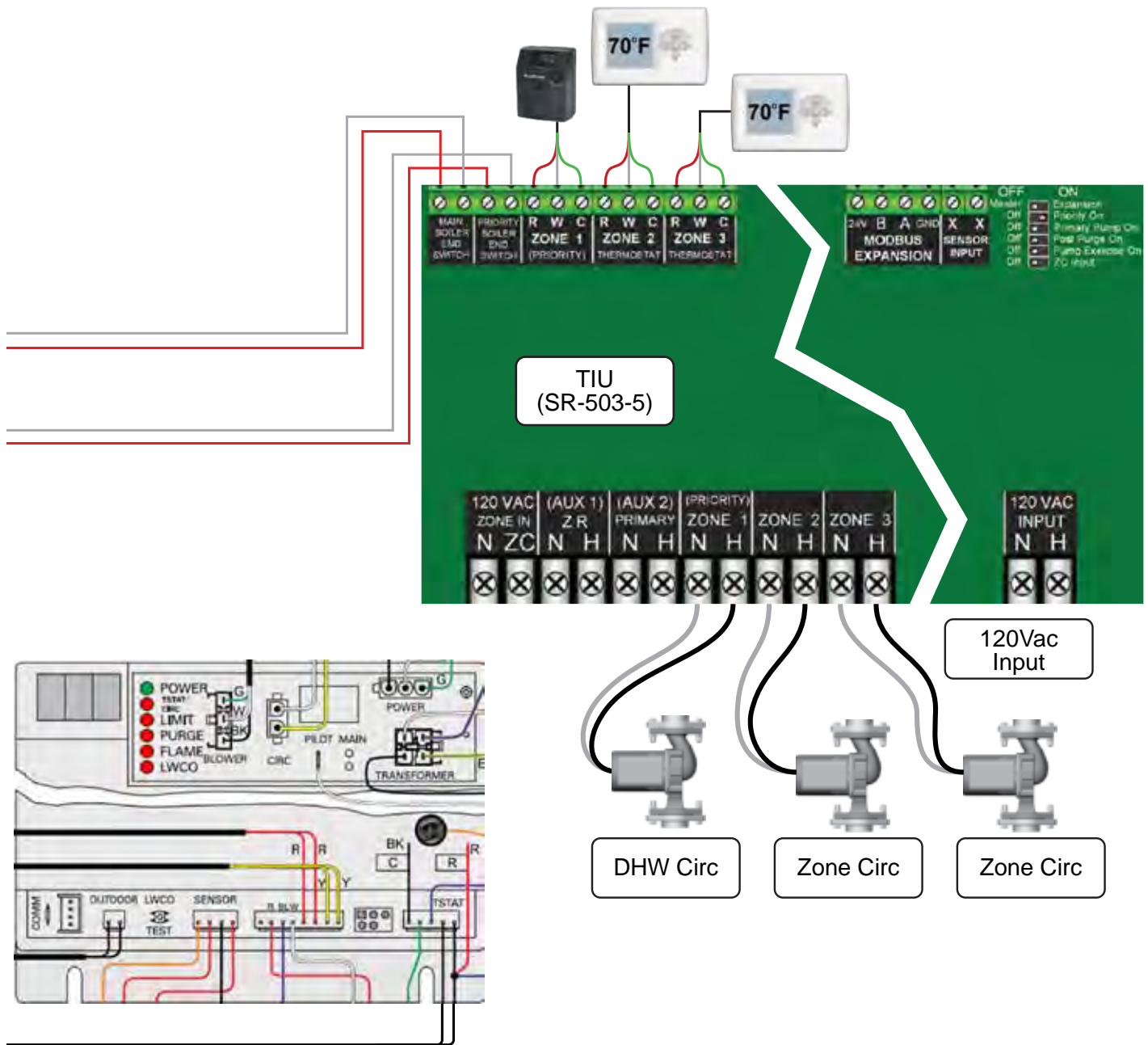

CGi connection shown



System Type B (continued)

Application B1: Multi-zone space heating DHW as zone, boiler direct piped (continued)

Control Settings

HP (Master) Configuration
See pg XX-YY for basic settings and navigation

Weather Temp. Settings

T1SetH1	Per ECOCalc
T1SetH2	Per ECOCalc
T4H1	Per ECOCalc
T4H2	Per ECOCalc

Heating Settings

T4HMAX	Per ECOCalc or as required
T4HMIN	Per ECOCalc

Other Heat Source

AHS function	Set to "Heating and DHW"
AHS_Pump_I Control	Set to "Not Run"
dT1_AHS_ON	Default (9F) or as required
t_AHS_Delay	Default (30min) or as required
T4_AHS_ON	Per ECOCalc

Boiler (Shadow) Configuration
If boiler has any outdoor reset functionality, ensure settings align with ECOCalc output



This page intentionally left blank.



System Type B (continued)

Application B2: Multi-zone space heating DHW as zone - Primary/Secondary

Overview

- Two zones for space heating, zoned with circulators, through the TIU.
- One zone for DHW, zoned with circulators, through the TIU.
- DHW Priority – space heating is disabled during DHW combi call.

U-Control Settings

- See table on [page 42](#) for boiler control settings.
- Refer to the boiler manual for specific control navigation information.

ECO HP Control Settings

- See table on [page 42](#) for heat pump control settings.
- Refer to [page 14](#) for heat pump control navigation information.

Circulators and piping

- Piping must be primary/secondary.
- If boiler will run concurrently with the ECO HP, the boiler must be downstream from ECO HP to prevent high return temperatures from shutting down the heat pump.
- A mixing valve should be used to ensure supplied DHW temperatures are properly limited.
- Zone circulators should be sized for required flow.
- Space heating zone circulators and DHW zone circulator provided by installer.
- Additional zones can be added with additional zone panels.
- Boiler circulator is shipped loose with the boiler.
- Heat Pump circulator is installed in heat pump manifold and included in the heat pump accessory box.

This system will run a DHW call until it is satisfied. It will also run other zones after 1 hour of a DHW call, if other zone calls are present. However, the Target Temperature on the heat pump will remain T1STOPH (max temperature) until the DHW call is satisfied.

All zones should either run properly and safely at supply temperatures up to 149°F or using mixing valves to supply proper temperatures to zones.

Boiler is limited to one priority/reset curve. If reset curve is enabled, DHW supply temperatures will vary based on the curve. Ensure curve is sufficient for DHW operation. It is recommended to set a single boiler target temperature and not use the boiler reset curve if supply temperatures will drop below 130°F for a DHW call.



System Type B (continued)

Application B2: Multi-zone space heating DHW as zone - Primary/Secondary (continued)

Application Piping

Legend

- | | | | |
|---|---|---|---|
| <ul style="list-style-type: none"> 1. ■ Boiler. 2. Indirect water heater, if used (domestic water piping not shown). 3. ■ Relief valve, supplied with boiler and heat pump, field piped. 4. Relief valve piping to drain. 5. DHW circulator. 6. Isolation valves. | <ul style="list-style-type: none"> 7. ■ Y-Strainer with 80 mesh screen. 8. Expansion tank. 9. Air separator. 10. Flow/check or spring check valves. 11. Purge/drain valves. 12. ■ Heat pump circulator. 13. Heat trap. | <ul style="list-style-type: none"> 14. Unions as needed for service. 17. ■ Eco™HP Heat Pump 18. ■ Boiler Circulator 20. Make-up water supply. 23. DHW Temperature and Pressure relief valve 24. Zone circulators. 25. ■ Boiler or heat pump drain valve, supplied with boiler or heat pump, field piped. | <ul style="list-style-type: none"> 26. Zone Valves. 27. Bypass pressure regulator 30. ■ Pressure/temperature gauge, supplied with boiler and heat pump, field piped. <p>■ = Items supplied with boiler or heat pump - all other Items supplied by installer.</p> |
|---|---|---|---|

Figure 25 Application B2: Multi-zone space heating DHW as zone - Primary/Secondary Application Piping

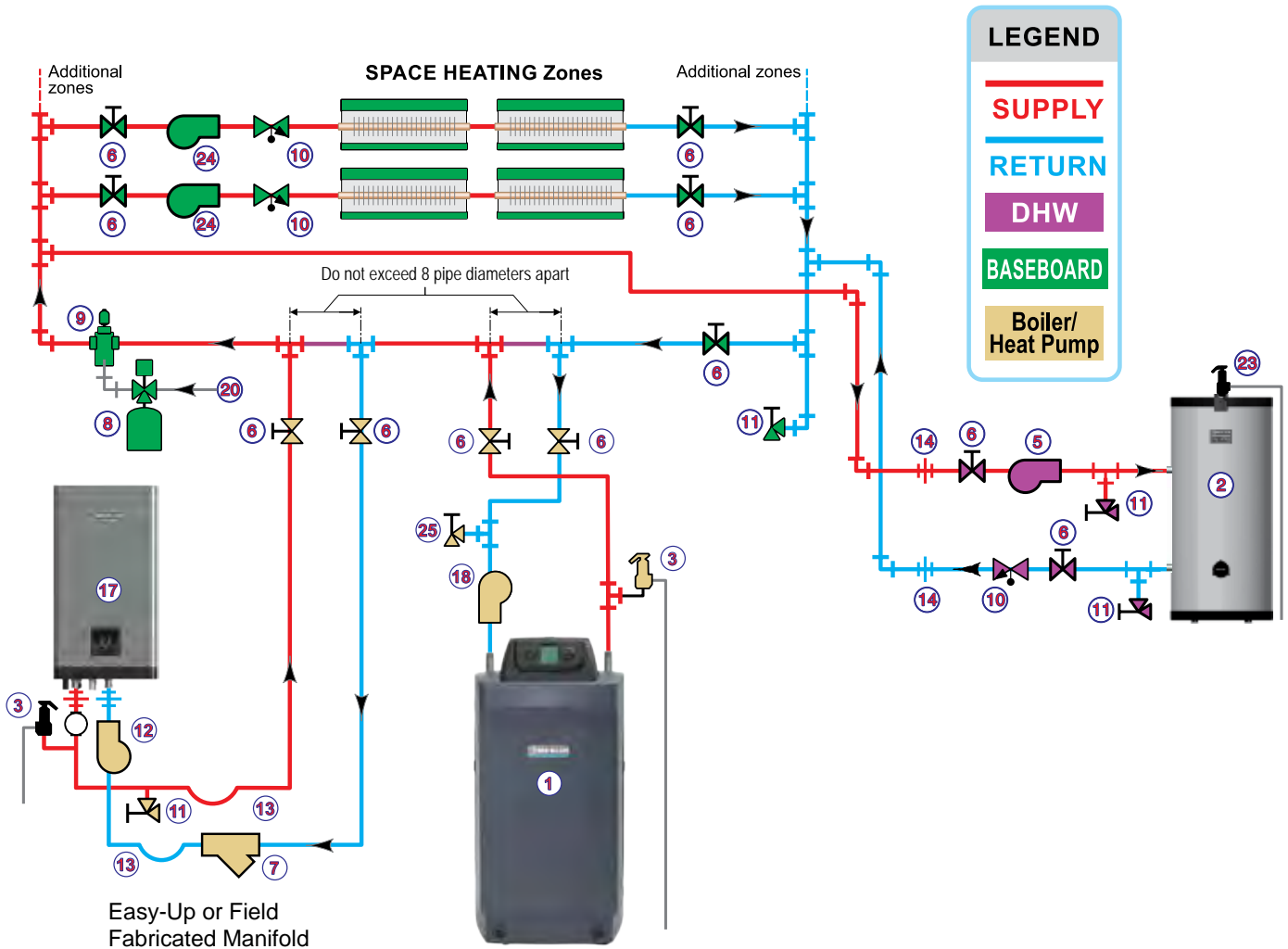

System Type B (continued)

Application B2: Multi-zone space heating DHW as zone - Primary/Secondary (continued)

Application Wiring

Figure 26 Application B2: Multi-zone space heating DHW as zone - Primary/Secondary Application Wiring

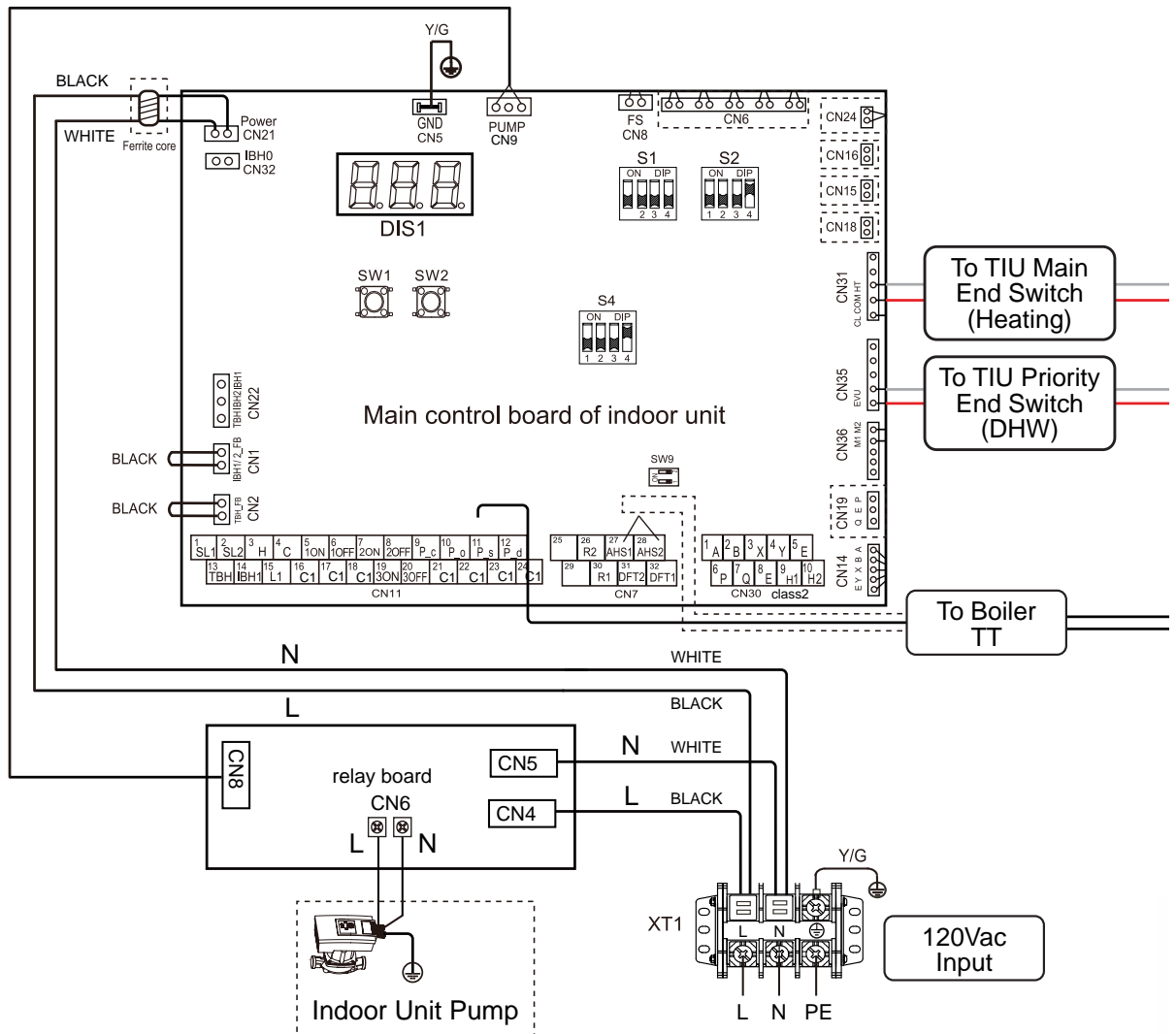

System Type B (continued)

Application B2: Multi-zone space heating DHW as zone - Primary/Secondary (continued)

Application Wiring (continued)

Figure 27 Application B2: Multi-zone space heating DHW as zone - Primary/Secondary Application Wiring

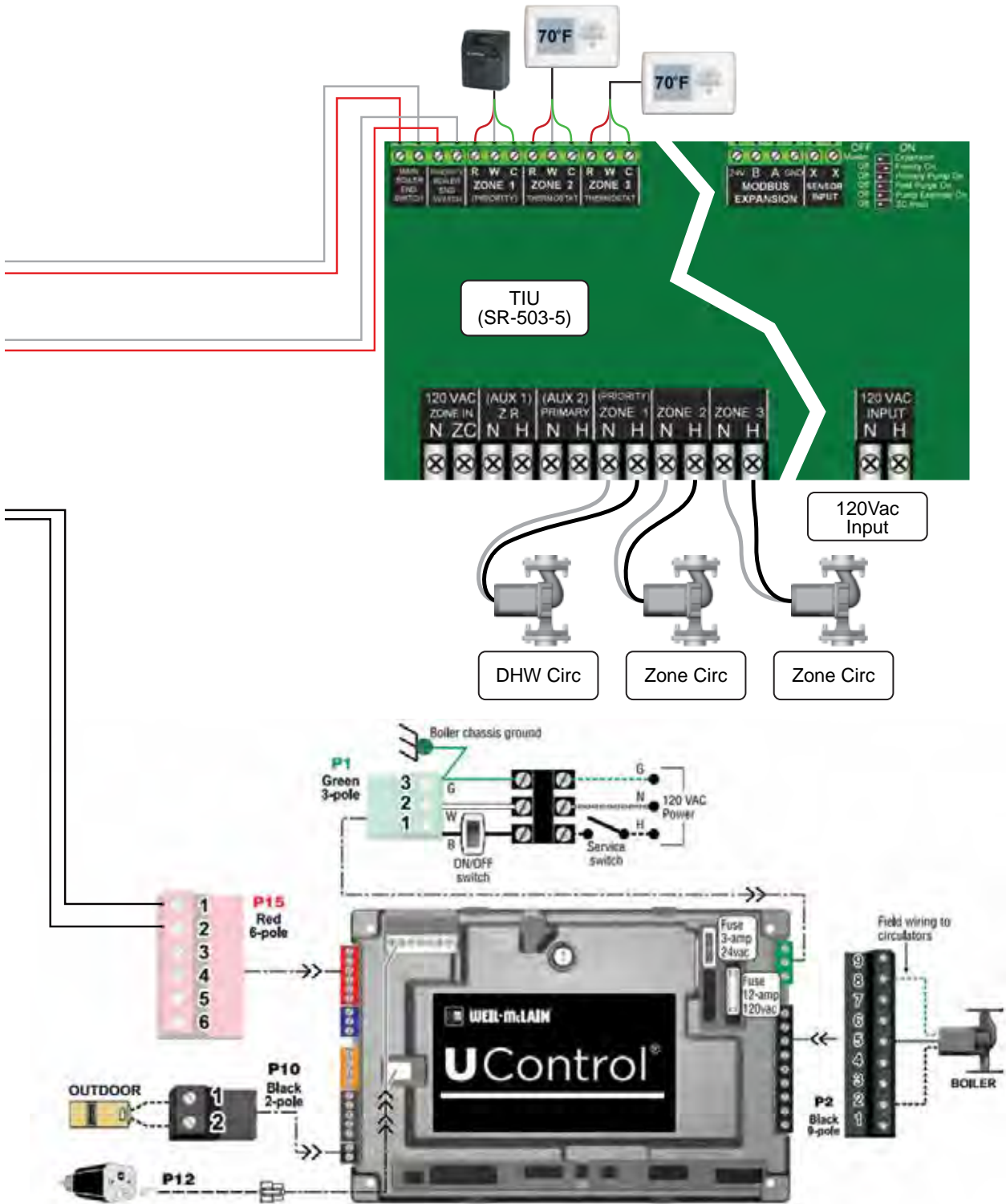



System Type B (continued)

Application B2: Multi-zone space heating DHW as zone - Primary/ Secondary (continued)

Control Settings

Boiler (Shadow) Configuration

After entering the contractor menu, ensure the settings in the following sub-menus are set as noted.

System Settings

PRIORITY 2

System Type	FIN BASE
-------------	----------

TEMPERATURES

Max Supply	Per ECOCalc
Min Supply	Per ECOCalc
Max OD Reset	Per ECOCalc
Min OD Reset	Per ECOCalc

TIMES

Max On Time	Default
Min On Time	Default

CIRCULATORS

Circulator 1	OFF
Circulator 2	ON
Circulator 3	OFF

HP (Master) Configuration

See pg XX-YY for basic settings and navigation

Weather Temp. Settings

T1SetH1	Per ECOCalc
T1SetH2	Per ECOCalc
T4H1	Per ECOCalc
T4H2	Per ECOCalc

Heating Settings

T4HMAX	Per ECOCalc or as required
T4HMIN	Per ECOCalc

Other Heat Source

AHS function	Set to "Heating and DHW"
AHS_Pump_I Control	Set to "Not Run"
dT1_AHS_ON	Default (9F) or as required
t_AHS_Delay	Default (30min) or as required
T4_AHS_ON	Per ECOCalc



This page intentionally left blank.



System Type B

Application B3: Multi-zone Space Heating boiler only DHW

Overview

- Three zones for space heating, zoned with circulators, through the TIU.
- One zone for DHW, direct piped with circulator, through boiler.
- DHW Priority – space heating is disabled during DHW combi call.

U-Control Settings

- See table on [page 48](#) for boiler control settings.
- Refer to the boiler manual for specific control navigation information.

ECO HP Control Settings

- See table on [page 48](#) for heat pump control settings.
- Refer to [page 14](#) for heat pump control navigation information.

Circulators and piping

- Piping must be primary/secondary.
- If boiler will run concurrently with the ECO HP, the boiler must be downstream from ECO HP to prevent high return temperatures from shutting down the heat pump.
- A mixing valve should be used to ensure supplied DHW temperatures are properly limited.
- Zone circulators should be sized for required flow.
- Space heating zone circulators and DHW zone circulator provided by installer.
- Additional zones can be added with additional zone panels.
- Boiler circulator is shipped loose with the boiler.
- Heat Pump circulator is installed in heat pump manifold and included in the heat pump accessory box.

This system will run a DHW call until the boiler Priority 1 Max On Time has elapsed. The heat pump may run space heat calls in parallel with the boiler during a DHW calls. If the boiler receives a space heat call (from the heat pump AHS output), the timer for Max On Time will start.

System Type B

Application B3: Multi-zone Space Heating boiler only DHW (continued)

Application Piping

Legend

- | | | | |
|---|---|--|---|
| <ul style="list-style-type: none"> 1. ■ Boiler. 2. Indirect water heater, if used (domestic water piping not shown). 3. ■ Relief valve, supplied with boiler and heat pump, field piped. 4. Relief valve piping to drain. 5. DHW circulator. 6. Isolation valves. | <ul style="list-style-type: none"> 7. ■ Y-Strainer with 80 mesh screen. 8. Expansion tank. 9. Air separator. 10. Flow/check or spring check valves. 11. Purge/drain valves. 12. ■ Heat pump circulator. 13. Heat trap. | <ul style="list-style-type: none"> 14. Unions as needed for service. 17. ■ Eco™ HP Heat Pump 18. ■ Boiler Circulator 20. Make-up water supply. 23. DHW Temperature and Pressure relief valve 24. Zone circulators. 25. ■ Boiler or heat pump drain valve, supplied with boiler or heat pump, field piped. | <ul style="list-style-type: none"> 26. Zone Valves. 27. Bypass pressure regulator 30. ■ Pressure/temperature gauge, supplied with boiler and heat pump, field piped. <p>■ = Items supplied with boiler or heat pump - all other items supplied by installer.</p> |
|---|---|--|---|

Figure 28 Application B3: Multi-zone Space Heating boiler only DHW Application Piping

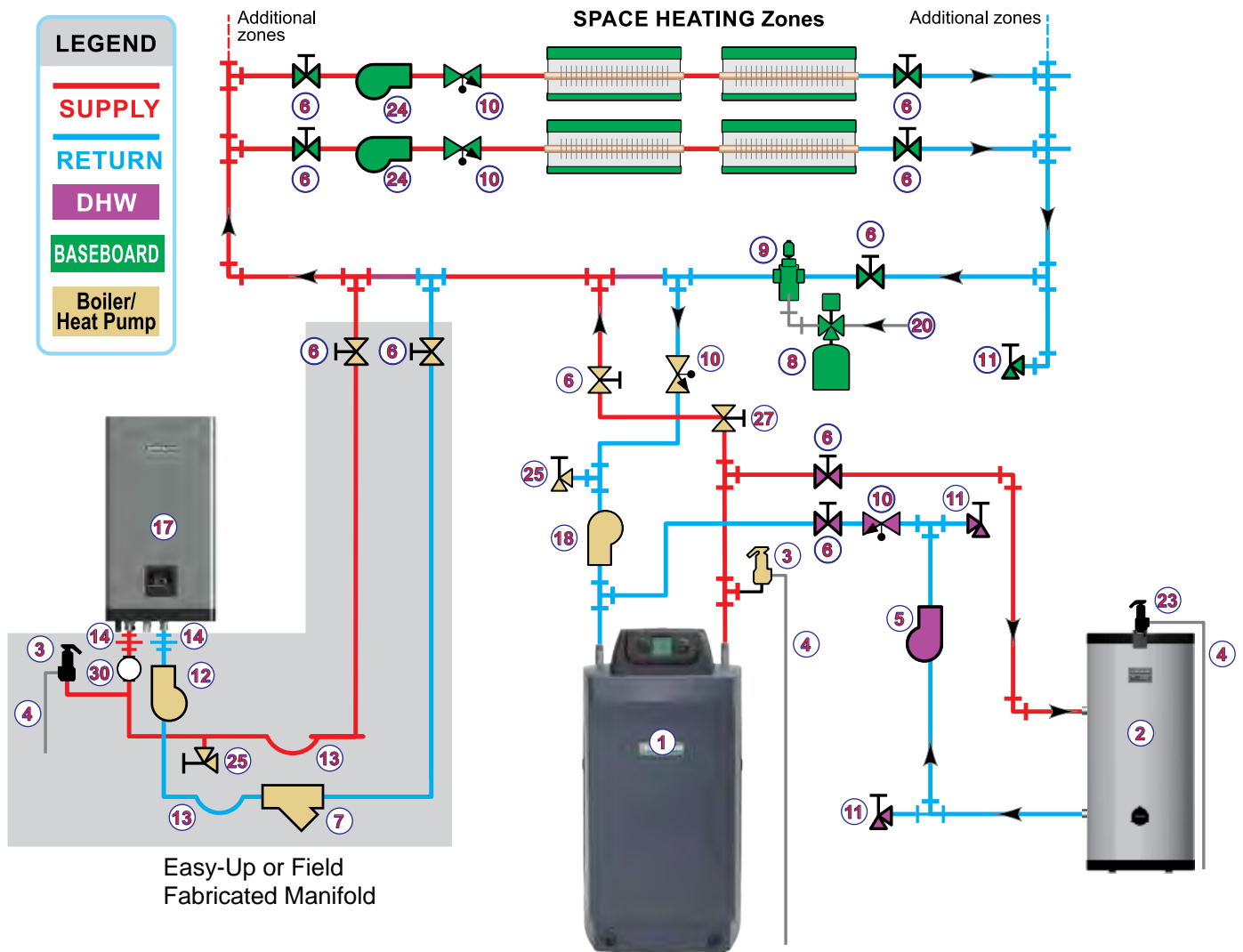

System Type B (continued)

Application B3: Multi-zone Space Heating boiler only DHW (continued)

Application Wiring

Figure 29 Application B3: Multi-zone Space Heating boiler only DHW Application Wiring

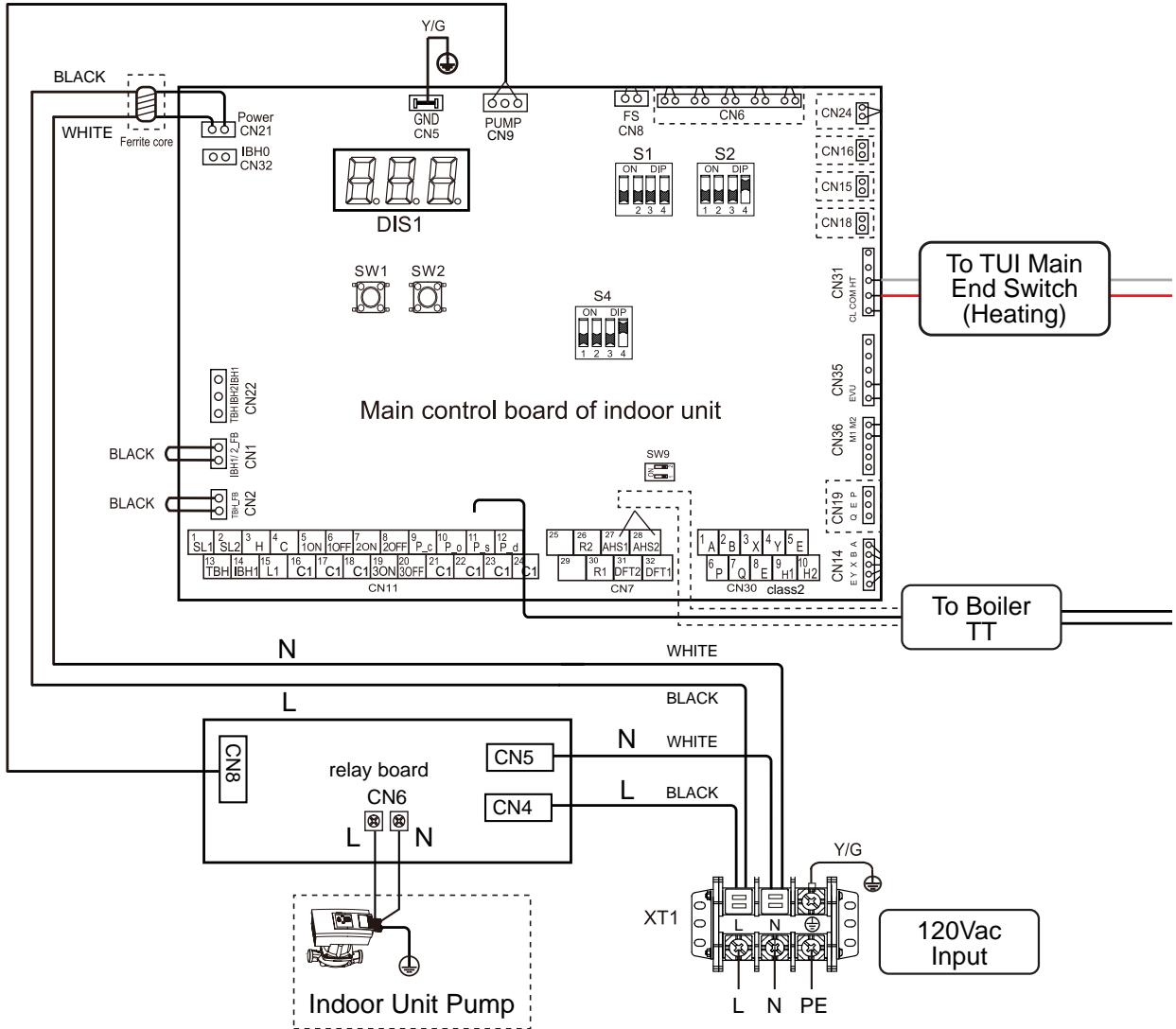

System Type B (continued)

Application B3: Multi-zone Space Heating boiler only DHW (continued)

Application Wiring (continued)

Figure 30 Application B3: Multi-zone Space Heating boiler only DHW Application Wiring

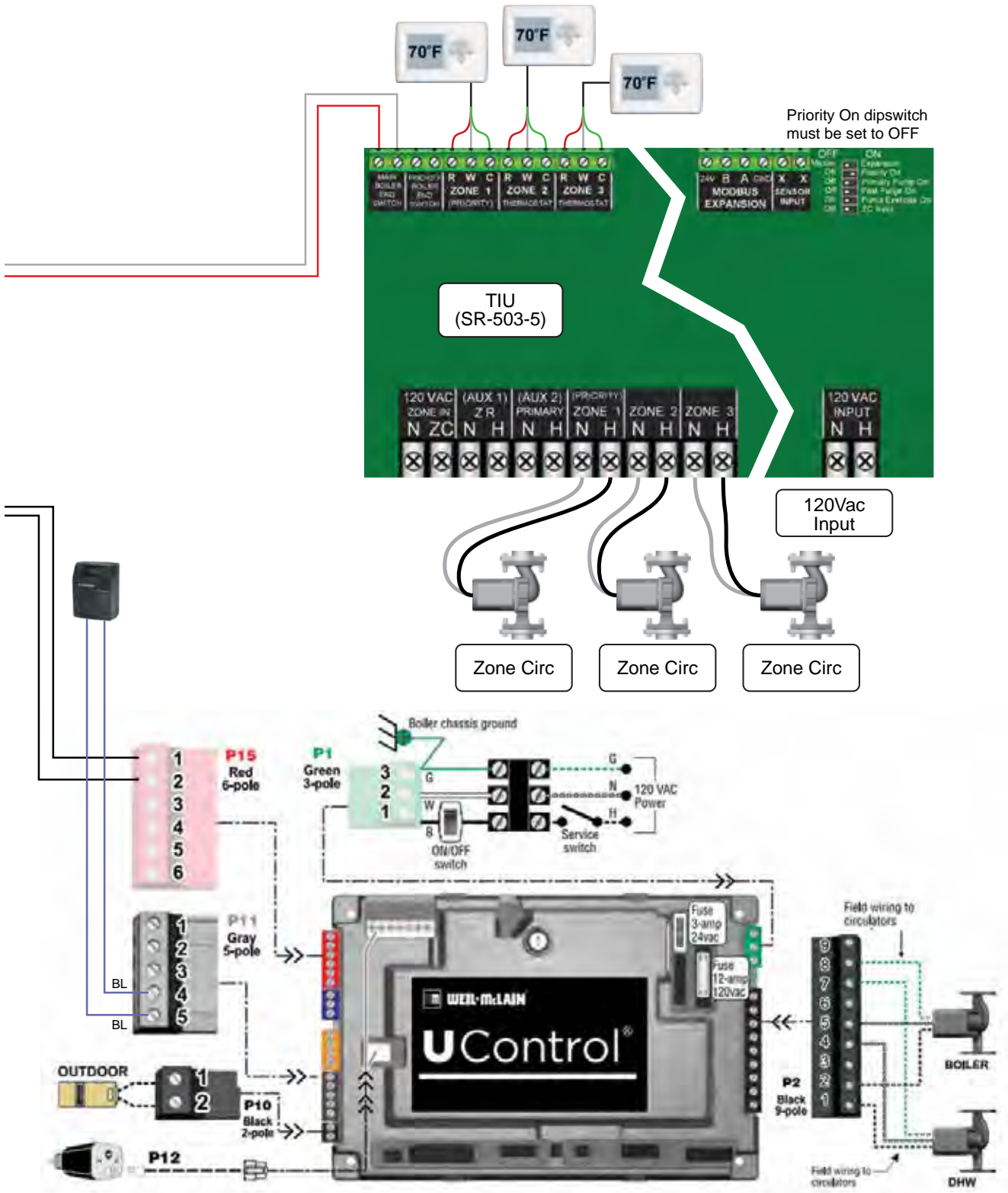



System Type B (continued)

Application B3: Multi-zone Space Heating boiler only DHW (continued)

Control Settings

Ultra Boiler (Shadow) Configuration

After entering the contractor menu, ensure the settings in the following sub-menus are set as noted.

System Settings	
PRIORITY 1	
System Type	DHW DIRECT
TEMPERATURES	
Max Supply	190 F
Min Supply	N/A
Max OD Reset	N/A
Min OD Reset	N/A
TIMES	
Max On Time	Default
CIRCULATORS	
Circulator 1	ON
Circulator 2	OFF
Circulator 3	OFF
PRIORITY 2	
System Type	FIN BASE
TEMPERATURES	
Max Supply	Per ECOCalc
Min Supply	Per ECOCalc
Max OD Reset	Per ECOCalc
Min OD Reset	Per ECOCalc
TIMES	
Max On Time	Default
Min On Time	Default
CIRCULATORS	
Circulator 1	OFF
Circulator 2	ON
Circulator 3	OFF



System Type B (continued)

Application B3: Multi-zone Space Heating boiler only DHW (continued)

Control Settings (continued)

HP (Master) Configuration
See pg XX-YY for basic settings and navigation

Weather Temp. Settings

T1SetH1	Per ECOCalc
T1SetH2	Per ECOCalc
T4H1	Per ECOCalc
T4H2	Per ECOCalc

Heating Settings

T4HMAX	Per ECOCalc or as required
T4HMIN	Per ECOCalc

Other Heat Source

AHS function	Set to "Heating"
AHS_Pump_I Control	Set to "Not Run"
dT1_AHS_ON	Default (9F) or as required
t_AHS_Delay	Default (30min) or as required
T4_AHS_ON	Per ECOCalc



System Type C

Application C1: Multi-zone Space Heating

Overview

- Three zones for space heating, zoned with circulators, through the TIU.

ECO HP Control Settings

- See table on [page 54](#) for heat pump control settings.
- Refer to [page 14](#) for heat pump control navigation information.

Circulators and piping

- Piping must be primary/secondary.
- Zone circulators should be sized for required flow.
- Space heating zone circulators provided by installer.
- Additional zones can be added with additional zone panels.
- Heat Pump circulator is installed in heat pump manifold and included in the heat pump accessory box.

System Type C (continued)

Application C1: Multi-zone Space Heating (continued)

Application Piping

Legend

- | | | | |
|---|--|---|---|
| <ul style="list-style-type: none"> 3. ■ Relief valve, supplied with boiler and heat pump, field piped. 4. Relief valve piping to drain. 6. Isolation valves. 7. ■ Y-Strainer with 80 mesh screen. 8. Expansion tank. | <ul style="list-style-type: none"> 9. Air separator. 10. Flow/check or spring check valves. 11. Purge/drain valves. 12. ■ Heat pump circulator. 13. Heat trap. 14. Unions as needed for service. | <ul style="list-style-type: none"> 17. ■ Eco™ HP Heat Pump 20. Make-up water supply. 24. Zone circulators. 25. ■ Boiler or heat pump drain valve, supplied with boiler or heat pump, field piped. 26. Zone Valves. | <ul style="list-style-type: none"> 27. Bypass pressure regulator 30. ■ Pressure/temperature gauge, supplied with boiler and heat pump, field piped. <p>■ = Items supplied with boiler or heat pump - all other items supplied by installer.</p> |
|---|--|---|---|

Figure 31 Application C1: Multi-zone Space Heating Application Piping

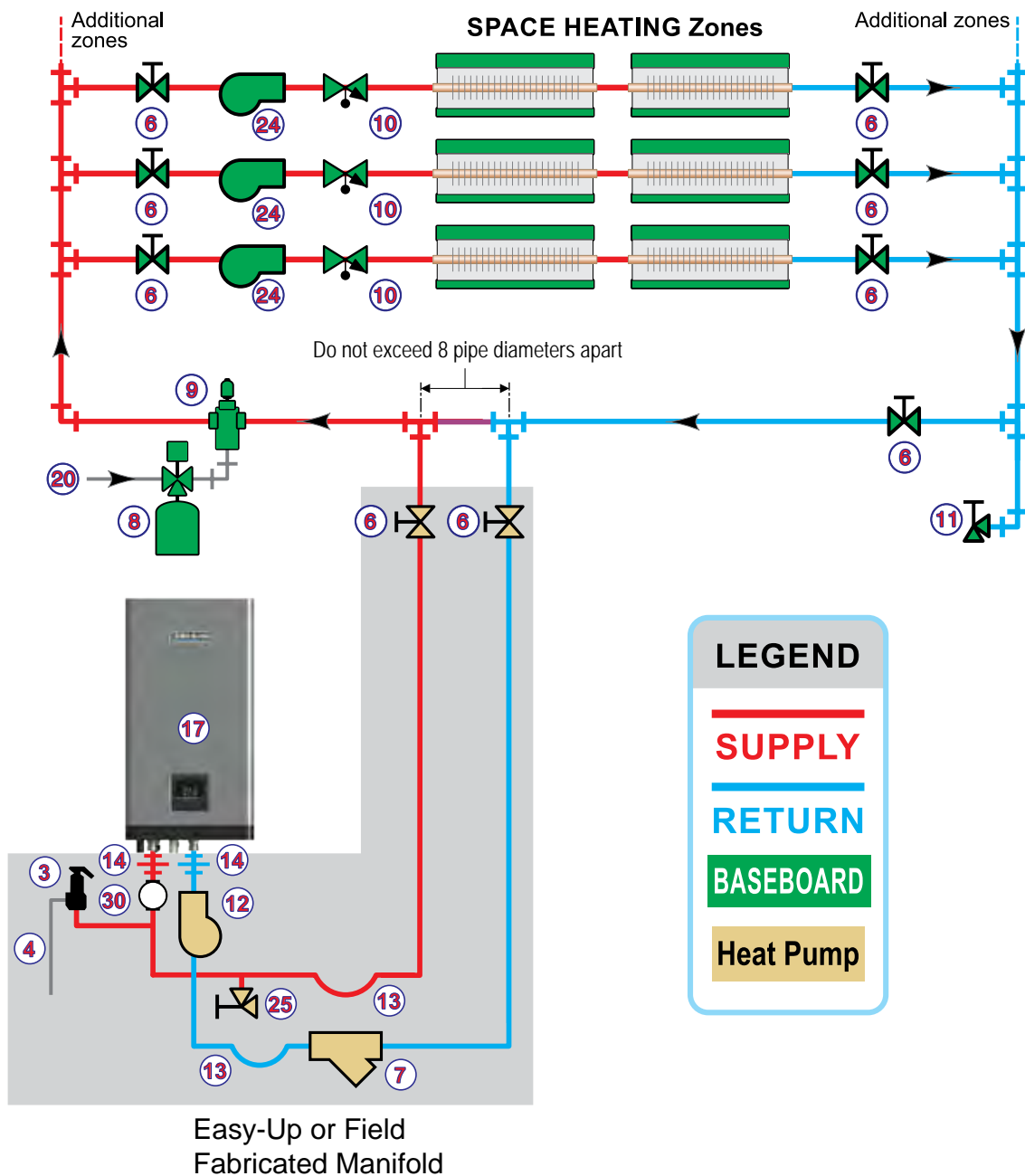

System Type C (continued)

Application C1: Multi-zone Space Heating (continued)

Application Wiring

Figure 32 Application C1: Multi-zone Space Heating Application Wiring

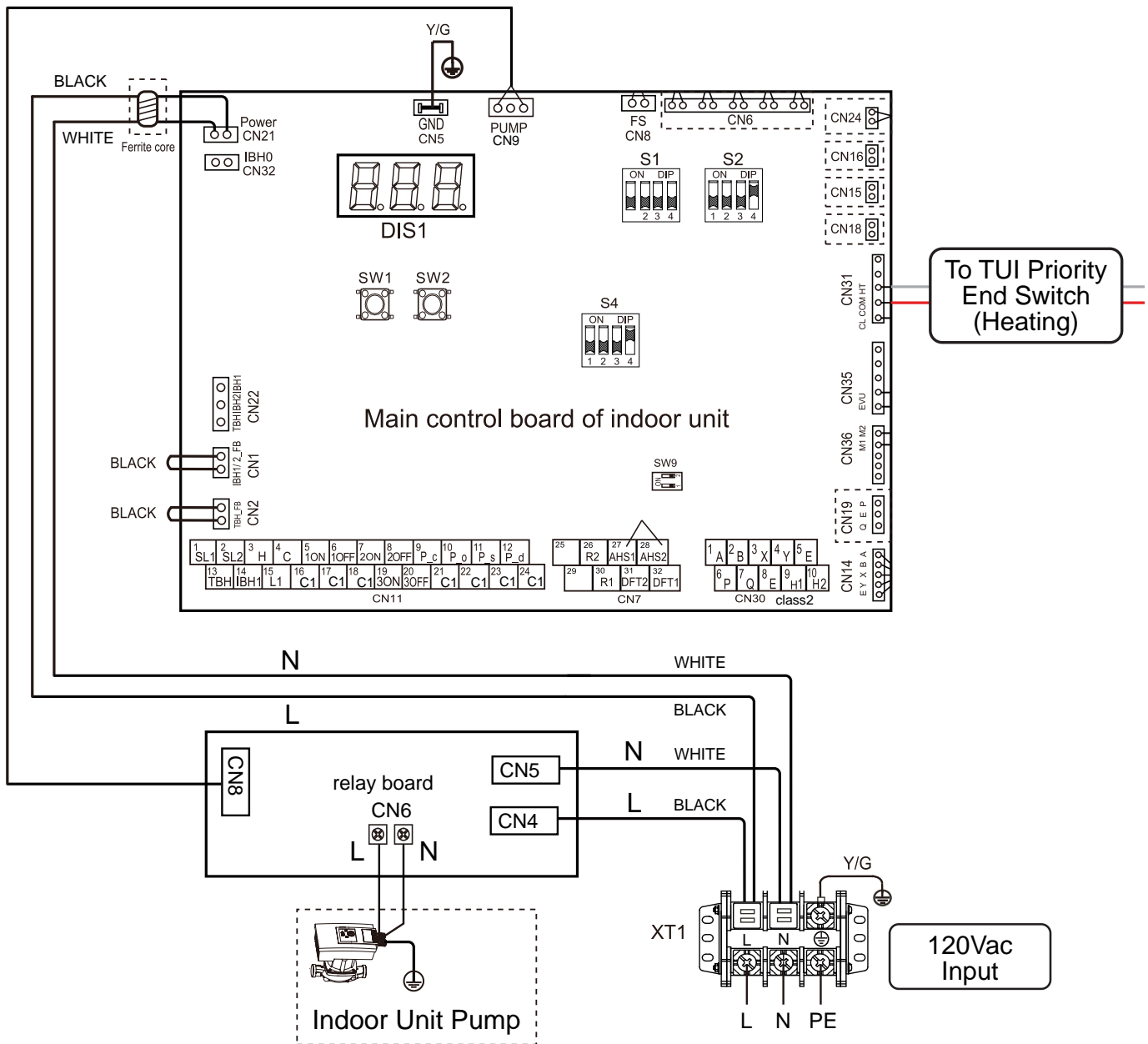

System Type C (continued)

Application C1: Multi-zone Space Heating (continued)

Application Wiring (continued)

Figure 33 Application C1: Multi-zone Space Heating Application Wiring

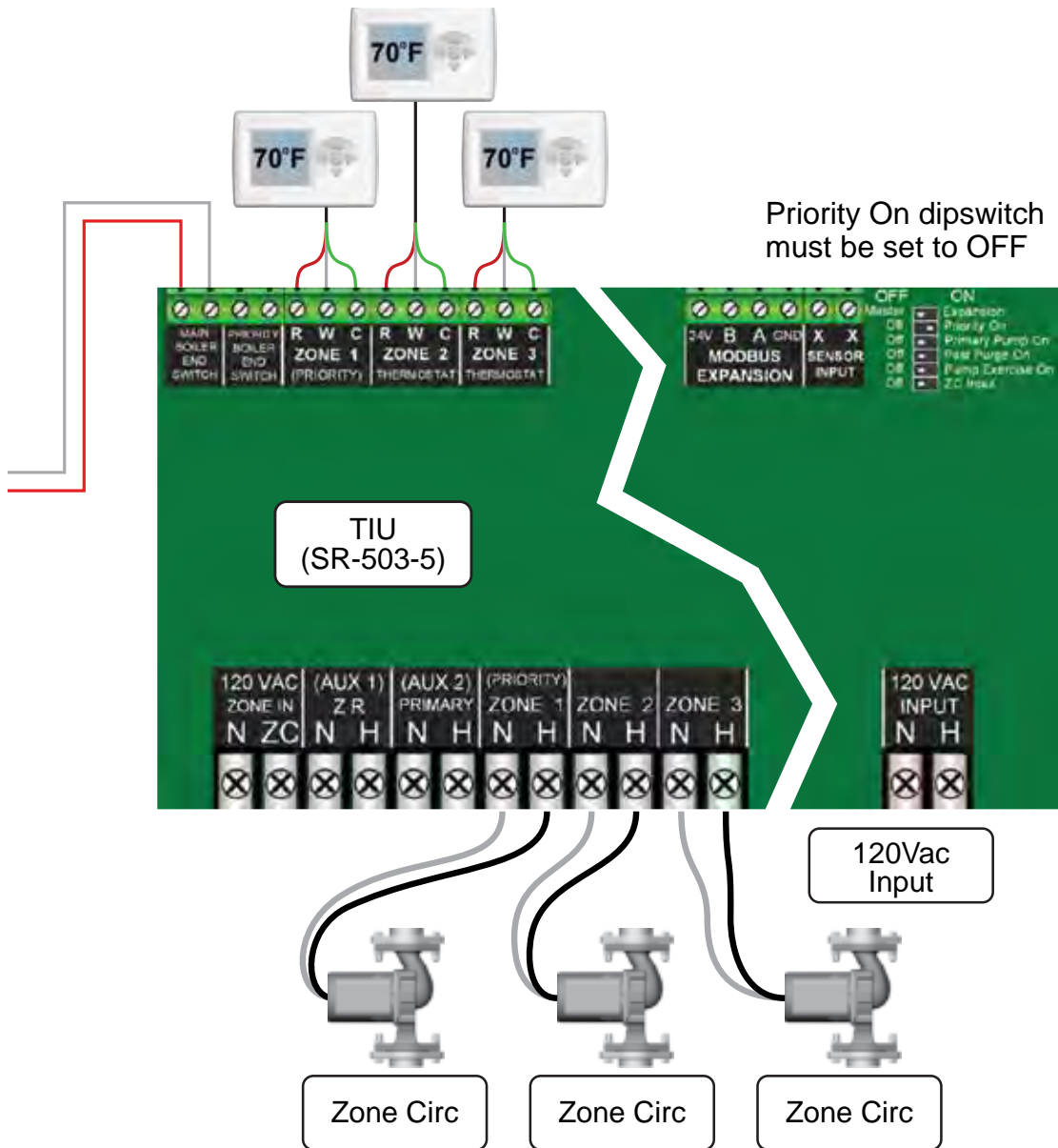



System Type C (continued)

Application C1: Multi-zone Space Heating (continued)

Control Settings

HP (Master) Configuration
See pg XX-YY for basic settings and navigation

Weather Temp. Settings

T1SetH1	Per ECOCalc
T1SetH2	Per ECOCalc
T4H1	Per ECOCalc
T4H2	Per ECOCalc

Heating Settings

T4HMAX	Per ECOCalc
T4HMIN	Per ECOCalc

Other heat source

AHS function	Set to OFF
--------------	------------

Type C installations must ensure heat pump is properly sized for location, climate and application. No auxiliary heat is available. See Type A and Type B installations for auxiliary heat applications.

For proper three zone operation with the TIU, Priority On dipswitch must be set to OFF



This page intentionally left blank.



System Type C (continued)

Application C2: Multi-zone Space Heating

Overview

- Multiple zones for space heating only, zoned with zone valves, end switches wired to the HP.

ECO HP Control Settings

- See table on [page 59](#) for heat pump control settings.
- Refer to [page 14](#) for heat pump control navigation information.

Circulators and piping

- Piping must be primary/secondary.
- System circulator should be sized for required head.
- System circulator provided by installer if circulator draws more than 0.2A, an isolation relay must be used.
- Heat Pump circulator is installed in heat pump manifold and included in the heat pump accessory box.

System Type C (continued)

Application C2: Multi-zone Space Heating (continued)

Application Piping

Legend

- | | | | |
|---|--|---|---|
| <ul style="list-style-type: none"> 3. ■ Relief valve, supplied with boiler and heat pump, field piped. 4. Relief valve piping to drain. 6. Isolation valves. 7. ■ Y-Strainer with 80 mesh screen. 8. Expansion tank. | <ul style="list-style-type: none"> 9. Air separator. 10. Flow/check or spring check valves. 11. Purge/drain valves. 12. ■ Heat pump circulator. 13. Heat trap. 14. Unions as needed for service. | <ul style="list-style-type: none"> 17. ■ Eco™ HP Heat Pump 19. System Circulator 20. Make-up water supply. 25. ■ Boiler or heat pump drain valve, supplied with boiler or heat pump, field piped. 26. Zone Valves. | <ul style="list-style-type: none"> 27. Bypass pressure regulator 30. ■ Pressure/temperature gauge, supplied with boiler and heat pump, field piped. <p>■ = Items supplied with boiler or heat pump - all other items supplied by installer.</p> |
|---|--|---|---|

Figure 34 Application C2: Multi-zone Space Heating Application Piping

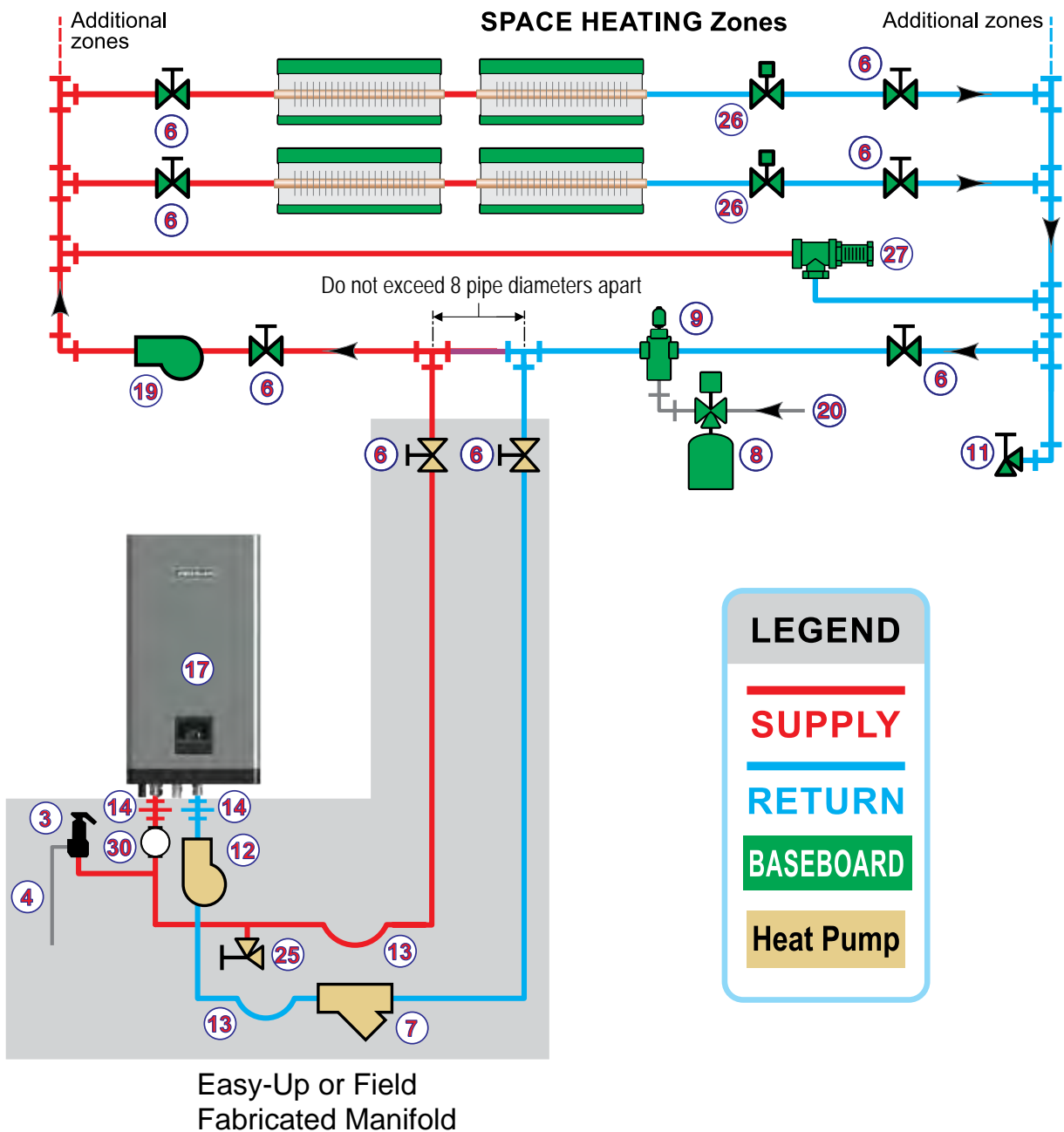

System Type C (continued)

Application C2: Multi-zone Space Heating (continued)

Application Wiring

Figure 35 Application C2: Multi-zone Space Heating Application Wiring

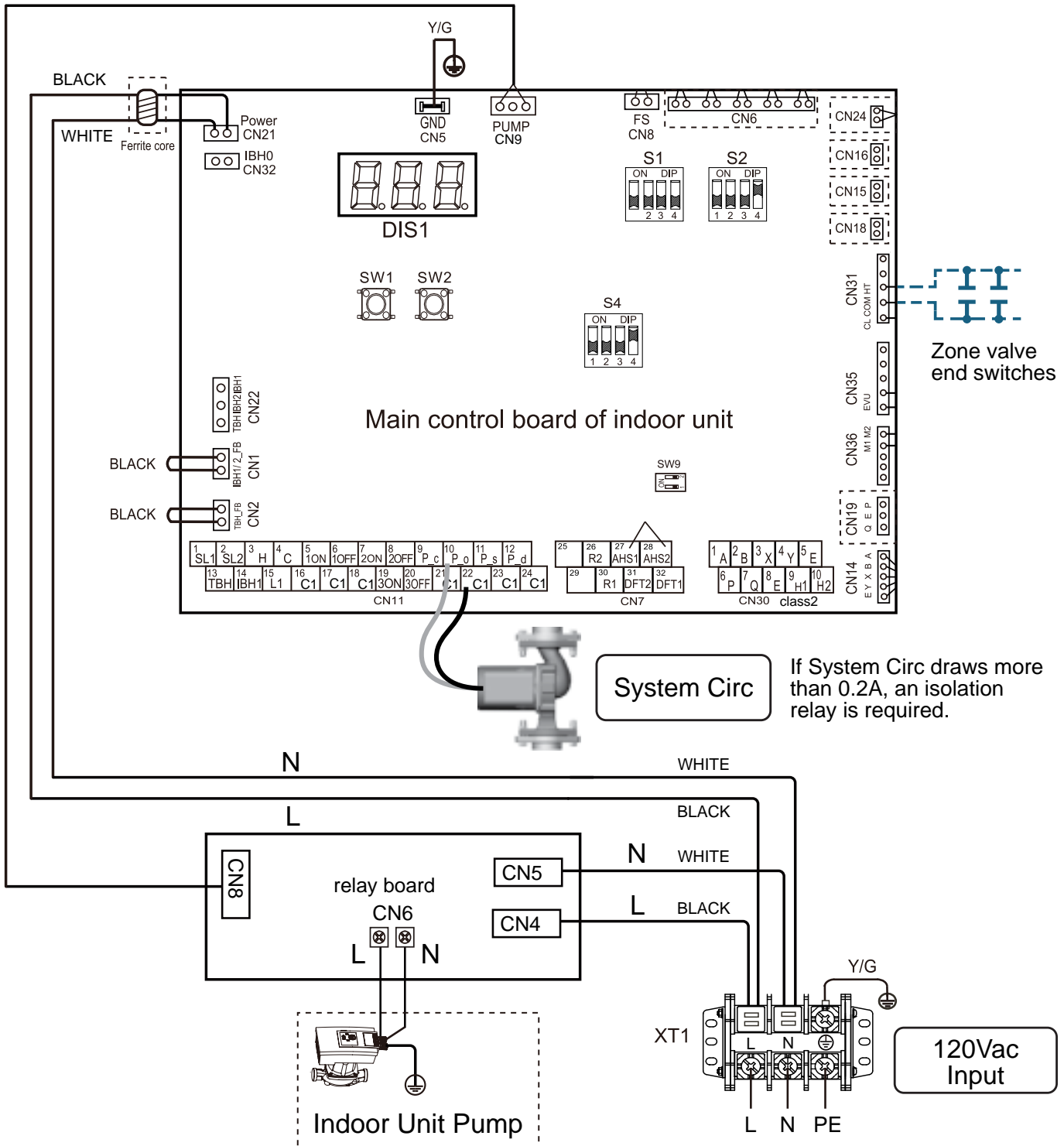



System Type C (continued)

Application C2: Multi-zone Space Heating (continued)

Control Settings

HP (Master) Configuration
See pg XX-YY for basic settings and navigation

Weather Temp. Settings

T1SetH1	Per ECOCalc
T1SetH2	Per ECOCalc
T4H1	Per ECOCalc
T4H2	Per ECOCalc

Heating Settings

T4HMAX	Per ECOCalc
T4HMIN	Per ECOCalc

Other heat source

AHS function	Set to OFF
--------------	------------

Type C installations must ensure heat pump is properly sized for location, climate and application. No auxiliary heat is available. See Type A and Type B installations for auxiliary heat applications.

For proper three zone operation with the TIU, Priority On dipswitch must be set to OFF



System Type C (continued)

Application C3: Multi-zone space heating DHW as zone

Overview

- Two zones for space heating, zoned with circulators, through the TIU.
- One zone for DHW, direct piped with circulator, through the TIU.
- DHW Priority – space heating is disabled during DHW combi call.

ECO HP Control Settings

- See table on [page 64](#) for heat pump control settings.
- Refer to [page 14](#) for heat pump control navigation information.

Circulators and piping

- Piping must be primary/secondary
- A mixing valve should be used to ensure supplied DHW temperatures are properly limited.
- Zone circulators should be sized for required flow.
- Space heating zone circulators and DHW zone circulator provided by installer.
- Additional zones can be added with additional zone panels.
- Heat Pump circulator is installed in heat pump manifold and included in the heat pump accessory box.

Heat pump will operate DHW priority until satisfied. Ensure space heat zones can use up to 149°F supply temperatures or install mixing valves to ensure proper temperatures. If call is present, space heat will not operate until 1 hour after DHW call is initiated.

System Type C (continued)

Application C3: Multi-zone space heating DHW as zone (continued)

Application Piping

Legend

- | | | | |
|---|---|--|---|
| <ul style="list-style-type: none"> 2. Indirect water heater, if used (domestic water piping not shown). 3. ■ Relief valve, supplied with boiler and heat pump, field piped. 4. Relief valve piping to drain. 5. DHW circulator. 6. Isolation valves. | <ul style="list-style-type: none"> 7. ■ Y-Strainer with 80 mesh screen. 8. Expansion tank. 9. Air separator. 10. Flow/check or spring check valves. 11. Purge/drain valves. 12. ■ Heat pump circulator. | <ul style="list-style-type: none"> 13. Heat trap. 14. Unions as needed for service. 17. ■ Eco™ HP Heat Pump 20. Make-up water supply. 24. Zone circulators. 25. ■ Boiler or heat pump drain valve, supplied with boiler or heat pump, field piped. | <ul style="list-style-type: none"> 26. Zone Valves. 27. Bypass pressure regulator 30. ■ Pressure/temperature gauge, supplied with boiler and heat pump, field piped. <p>■ = Items supplied with boiler or heat pump - all other Items supplied by installer.</p> |
|---|---|--|---|

Figure 36 Application C3: Multi-zone space heating DHW as zone Application Piping

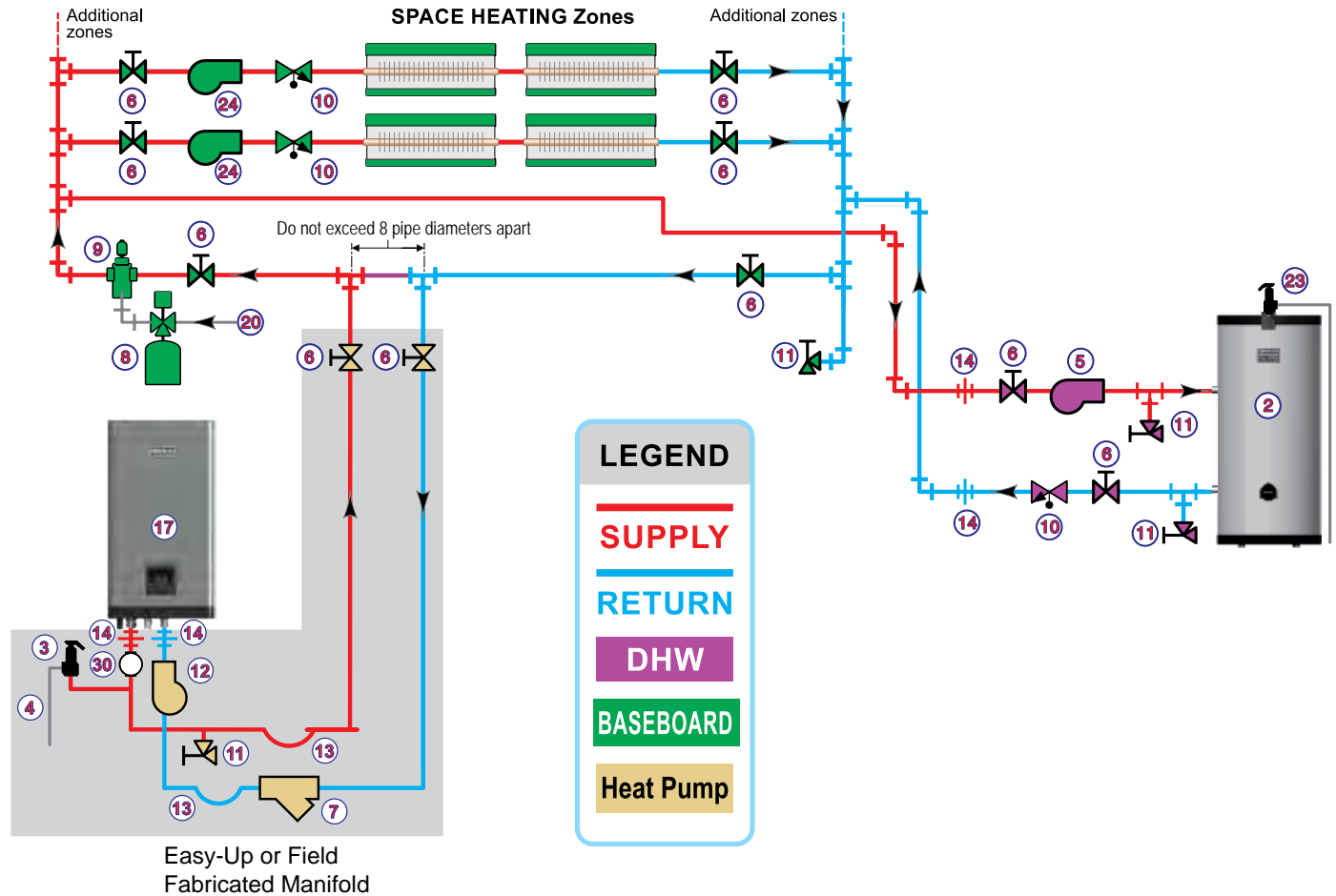

System Type C (continued)

Application C3: Multi-zone space heating DHW as zone (continued)

Application Wiring

Figure 37 Application C3: Multi-zone space heating DHW as zone Application Wiring

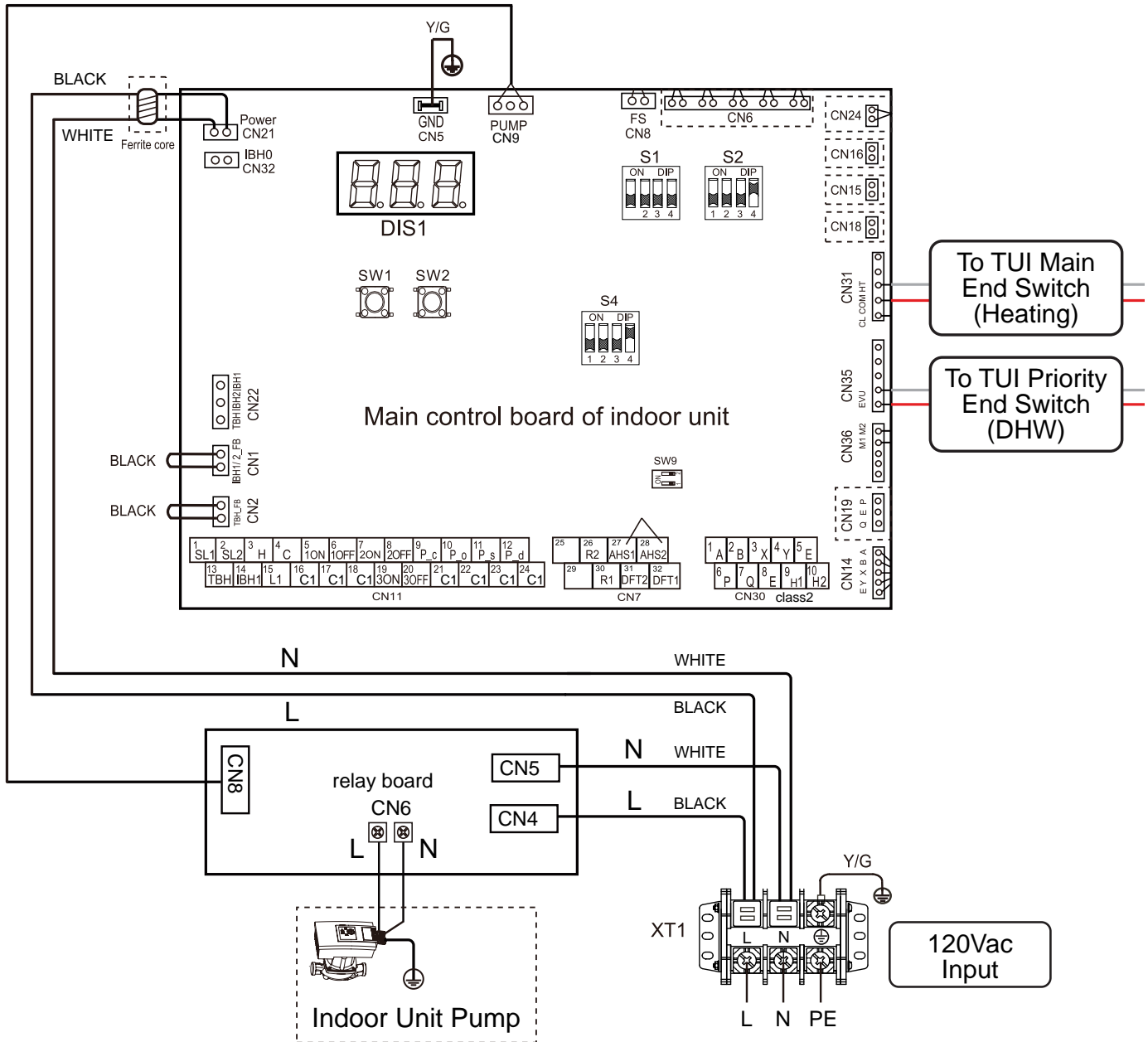

System Type C (continued)

Application C3: Multi-zone space heating DHW as zone (continued)

Application Wiring (continued)

Figure 38 Application C3: Multi-zone space heating DHW as zone Application Wiring

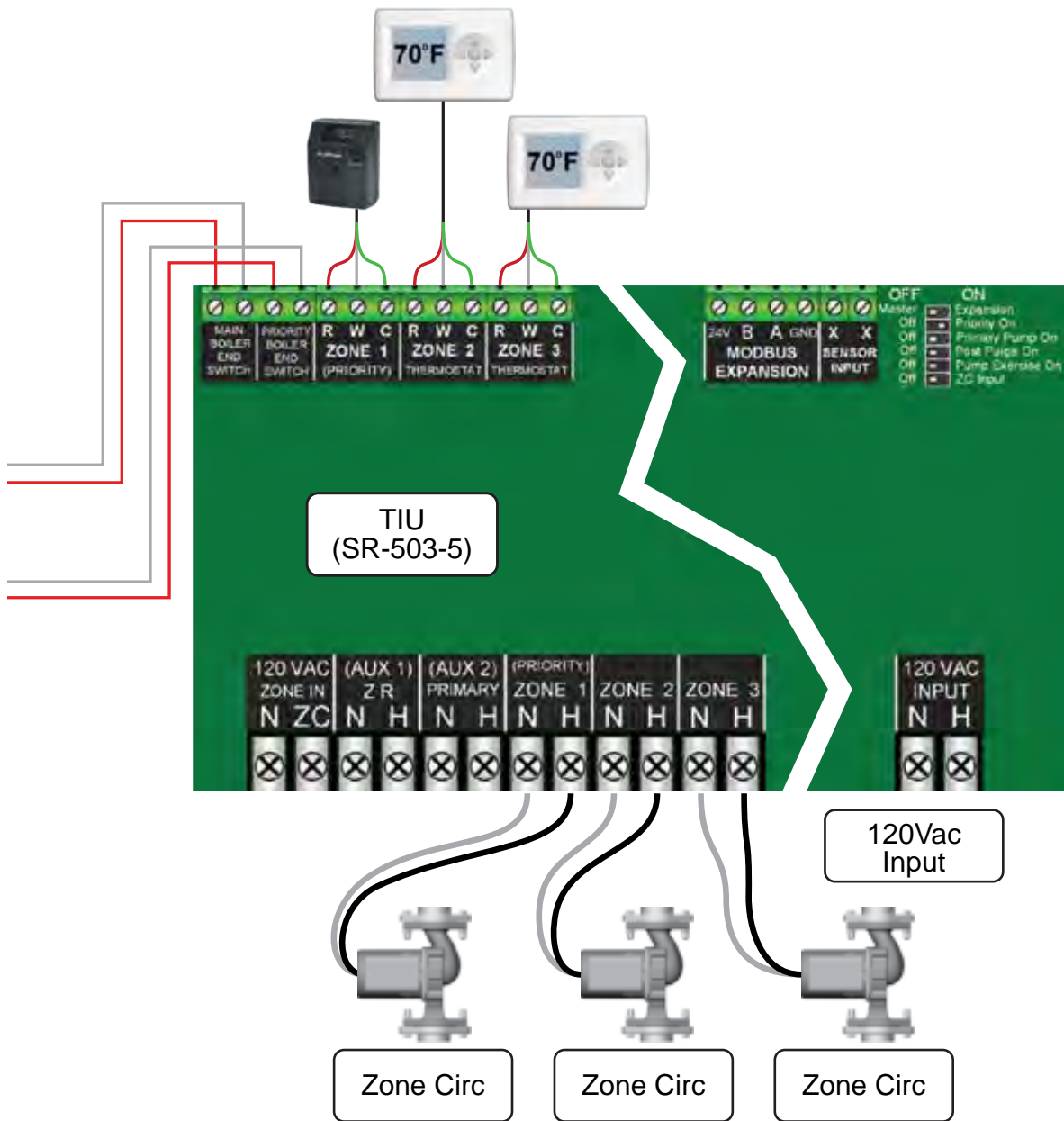



System Type C (continued)

Application C3: Multi-zone space heating DHW as zone (continued)

Control Settings

HP (Master) Configuration
See pg XX-YY for basic settings and navigation

Weather Temp. Settings

T1SetH1	Per ECOCalc
T1SetH2	Per ECOCalc
T4H1	Per ECOCalc
T4H2	Per ECOCalc

Heating Settings

T4HMAX	Per ECOCalc
T4HMIN	Per ECOCalc

Other heat source

AHS function	Set to OFF
--------------	------------

Type C installations must ensure heat pump is properly sized for location, climate and application. No auxiliary heat is available. See Type A and Type B installations for auxiliary heat applications.

SECTION 4

COMMISSIONING/Troubleshooting

VERIFY PROPER OPERATION AFTER SERVICING

Please reference the Eco™ HP IDU manual and the relevant boiler manuals for specific startup instructions.

General Commissioning

Water Quality Requirements

Clean System to Remove Sediment

1. The system must be thoroughly flushed (without heat pump connected) to remove sediment. The high-efficiency heat exchanger can be damaged by buildup or corrosion due to sediment.
2. For zoned systems, flush each zone separately through a purge valve. (If purge valves and isolation valves are not already installed, install them to properly clean the system.)
3. Flush system until water runs clean and piping is free of sediment

WARNING

- Do not use petroleum-based cleaning or sealing compounds in hydronic heating system. Damage to elastomer seals and gaskets in system could occur, resulting in substantial property damage.
- Before filling the heat pump and system with water, verify the following. DO NOT fill with softened water. The corrosion can occur.
- Failure to comply could result in heat pump failure or unreliable operation

Water Chemistry

Water pH between 7.0 and 8.5

1. Maintain boiler water pH between 7.0 and 8.5. Check with litmus paper or have chemically analyzed by water treatment company.
2. If pH differs from above, consult local water treatment company for treatment needed.

Hardness less than 7 grains

1. Consult local water treatment companies for unusually hard water areas (above 7 grains hardness).

Chloride Concentration Must be LESS THAN 100 ppm

1. Filling with chlorinated fresh water should be acceptable since drinking water chloride levels are typically less than 5 ppm.
2. Do not use the heat pump to directly heat swimming pool or spa water.
3. Do not fill heat pump or operate with water containing chloride in excess of 100 ppm.

WARNING

Verify that the water chemistry meets the limitations and requirements of all other equipment in the system.

WM Required Chemicals:

Contact a WM technologies representative:

- Corrosion inhibitor, Sentinel X100
- Sentinel X100 Quick Test Kit

Antifreeze and Correct Dosage Amount

Use only antifreeze listed by WM Technologies as suitable for use with ECO HP Split Air-to-Water Heat Pump. See below for information to obtain antifreeze through a WM Technologies distributor.

1. Determine the freezing temperature needed (to protect against lowest likely temperature the system water will encounter).
2. Find the antifreeze concentration by volume needed for this temperature from the antifreeze manufacturer's data on the antifreeze container.
3. Add up the volume (gallons) of all system piping and components, including the expansion tank and heat pump.
 - a. Heat pump water content is 0.41 gallons.
 - b. Remember to include expansion tank water content.
4. Multiply this volume by the (percent) antifreeze needed to find the number of gallons of antifreeze to add.

General Commissioning (continued)

Fill and Test Water System

1. Fill system only after ensuring the water meets the requirements of this manual.
2. Close manual and automatic air vents and heat pump drain valve.
3. Fill to correct system pressure. Correct pressure will vary with each application.
 - a. Typical cold water fill pressure for a residential system is 12 psi.
 - b. Pressure will rise when heat pump is turned on and system water temperature increases. Operating pressure must never exceed 24 PSIG.
4. At initial fill and during heat pump startup and testing, check system thoroughly for any leaks. Repair all leaks before proceeding further.

WARNING

Eliminate all system leaks. Continual fresh make-up water will reduce boiler life. Minerals can build up in the heat exchanger, reducing heat transfer, overheating heat exchanger, and causing heat exchanger failure.

Purge Air from Water System

1. Connect a hose to the system purge valve. Route hose to an area where water can drain and be seen.
2. Close the heat pump or system isolation valve between the purge valve and fill connection to the system.
3. Close zone isolation valves.
4. Open quick-fill valve on cold water make-up line.
5. Open purge valve.

Freeze Protection (if used)

Follow these guidelines to prevent possibility of severe personal injury, death or substantial property damage:

WARNING

- Use only the products listed by WM Technologies for use with this boiler. See WM Required Chemicals section on previous page for information.
- Thoroughly flush any system that has used glycol before installing the heat pump.
- Review the material safety data sheets (MSDS) are available online. The MSDS contains information on potential hazards and first aid procedures for exposure or ingestion.
- Check antifreeze inhibitor level at least annually. Glycol concentration and inhibitor levels may change over time. Add antifreeze to increase concentration if necessary. Add inhibitor as needed to bring to acceptable level, using inhibitor test kit to verify.

- In addition to antifreeze and inhibitor, use and maintain minimum level of Sentinel X100 inhibitor as directed on this page.
- If using freeze protection fluid with automatic fill, install a water meter to monitor water make-up. Freeze protection fluid may leak before the water begins to leak, causing concentration to drop, reducing the freeze protection level.
- DO NOT exceed 50% antifreeze by volume. Antifreeze moves more sluggishly than water and can interfere with heat transfer. At antifreeze concentrations higher than 50%, sludge can develop in heat pump, potentially causing damage to the heat exchanger.
- Clean the system before filling. Always drain and flush the system thoroughly before filling with antifreeze. Sludge, iron oxide deposits and other sediment in the system inhibit flow and can cause rapid breakdown of inhibitors.
- Use only antifreeze recommended by WM Technologies.

NOTICE

WM Technologies provides information for application of the antifreeze products listed in this document only for use in Weil-McLain heat pump. Do not apply these products or instructions for other applications. Local codes may require a back flow preventer or actual disconnection from city water supply.

6. One zone at a time, open the isolation valves. Allow water to run through the zone, pushing out the air. Run until no noticeable air flow is present. Close the zone isolation valves and proceed with the next zone. Follow this procedure until all zones are purged. Follow the same procedure to purge air from the boiler and its internal piping.
7. Close the quick-fill water valve and purge valve and remove the hose. Open all isolation valves. Watch that system pressure rises to correct cold-fill pressure.
8. After the system has operated for a while, eliminate any residual air by using the manual air vents located throughout the system.
9. If purge valves are not installed in system, open manual air vents in system one at a time, beginning with lowest floor. Close vent when water squirts out. Repeat with remaining vents.
10. Open automatic air vent (diaphragm-type or bladder-type expansion tank systems only) one turn.
11. Starting on the lowest floor, open air vents one at a time until water squirts out.
12. Repeat with remaining vents.
13. Refill to correct pressure.

General Commissioning (continued)

X100 Inhibitor is Required

⚠ WARNING

1. It is required that the ECO HP Split Air-to-Water Heat Pump have Sentinel X100 added to the system to prevent damage to its heat exchanger. See WM Required Chemicals section on previous page for part number ordering information.
2. After filling the system as directed in these instructions, fill with the X100 aerosol, following the instructions on the container.
3. After adding the inhibitor to the system, allow time for the water to circulate and mix. Then check the inhibitor level. Add additional inhibitor if necessary.
4. See separate instructions or weil-mclain.com for suggested guidelines to determine how much inhibitor to use.

Check/Verify Water Chemistry

1. The system may have residual substances that could affect water chemistry.
2. After the system has been filled and leak tested, verify water pH and chloride concentrations are acceptable.
3. Test the pH of a sample of system water at least annually. The pH of the water mixture must be between 7.0 and 8.5. (Or use the Sentinel inhibitor test kit to check concentration.)
4. If pH is outside this range (or inhibitor test kit indicates low level), the inhibitor level may not be sufficient to prevent corrosion.
5. Verify and test antifreeze concentration, if used.

⚠ WARNING

Test antifreeze concentration at least annually. If concentration is low, add antifreeze or drain system and refill with correct mixture.

6. Follow instructions on antifreeze container to determine the amount of antifreeze needed. DO NOT exceed 50% by volume concentration of antifreeze.
7. Follow the instructions on the Sentinel test kit to sample the system water and verify inhibitor concentration.
8. Check inhibitor level after adjustments are made. Check concentration annually.

Verify Thermostat Circuits

1. To avoid wiring errors, mark wires connected thermostat inputs on the control board (Unity 2.0 board for System Type A applications and the TIU board for System Type B and C applications). Disconnect wires.

2. Close each thermostat, zone valve and/or relay in the external circuit one at a time and check the voltmeter reading at each wire to a ground to ensure no voltage is being feed back into the boiler's control module.
3. There should NEVER be a voltage reading when external devise is closed.
4. If a voltage reading is measured on the incoming wires, check and correct the external wiring. DO NOT connect the thermostat terminals to 3-wire zone valves. This could cause control damage.
5. Once the external thermostat circuit wiring is checked and corrected, if necessary, reconnect the external thermostat circuit wires.

Verify Flow Rate Through Eco™HP

1. Check the hydraulic configuration to find out the space heating loops that can be closed by mechanical, electronic, or other valves.
2. Close all space heating loops that can be closed.
3. Start and operate the circulation pump.
 - a. The **Test run** menu in the **For Serviceman** menu contains a **Point check** menu where Pump_i can be actuated manually.
4. The circulator included with the Eco™HP can read flow through its accompanying iPhone or Android app. Refer to and follow the instructions included with the circulator to download the app and configure app to read flow rate.
 - a. If the app cannot be used for any reason, the pump can be set to just higher than the "MIN" on the speed dial, until a more accurate flow reading can be made. **It is recommended to set the dial to "MAX" which will provide a flow rate of around 9 gpm if using the WM Easy-Up Manifold.**
5. Read out the flow rate and adjust circulator speed until the set value reaches the minimum flow rate required greater than 3.08 gpm.

Verify Heating Operation

1. For system **Type A** applications:
 - a. provide a thermostat call to test. The Eco™HP should run and begin heating. If the Eco™HP does not run, verify the outdoor temperature or target temperature is not above or below application limits (if so, adjust AHD settings temporarily to enable test). Be sure to change back to application settings before finalizing commissioning.
 - b. To verify boiler operation AHD settings should be changed to operate boiler first. Refer to the boiler manual for startup checks. Be sure to change back to application settings before finalizing commissioning.

General Commissioning (continued)

2. For system **Type B** applications
 - a. Provide a thermostat call to test. The Eco™HP should run and begin heating. If the Eco™HP does not run, verify the outdoor temperature is not above or below application limits (if so, adjust T4HMAX and T4HMIN temporarily to enable test). Be sure to change back to application settings before finalizing commissioning.
 - b. The SG contacts can be used to force AHS calls, although no thermostat or DHW input call may. Close the contacts and the boiler should receive a call for heat and enable verification of proper function. Refer to the boiler manual for startup checks.
3. For system **Type C** applications
 - a. Provide a thermostat call to test. The Eco™HP should run and begin heating. If the Eco™HP does not run, verify the outdoor temperature is not above or below application limits (if so, adjust T4HMAX and T4HMIN temporarily to enable test). Be sure to change back to application settings before finalizing commissioning.
4. Repeat tests as needed for each zone or for DHW calls.

Troubleshooting

This section provides useful information for diagnosing and correcting certain troubles which may occur in the unit. This troubleshooting and related corrective actions may only be carried out by your local technician. Refer to the boiler and heat pump manuals for further information and troubleshooting details.

General Guidelines

Before starting the troubleshooting procedure, carry out a thorough visual inspection of the unit and look for obvious defects such as loose connections or defective wiring.

WARNING

When inspecting internal components ensure power is removed from the unit.

1. Inspect the most recent items listed in the error or lockout histories of each unit. See the error codes section for details on each error code for the Eco™HP
2. Using a volt-meter, verify both boiler and heat pump indoor unit have 120Vac power. Verify the heat pump outdoor unit has 240Vac. Refer to boiler and heat pump manuals for details on power connections.
3. Ensure thermostat is providing call for heat and 24Vac is present between thermostat wires and ground.
4. Verify no safety devices have been activated. If a safety device was activated, stop the unit and find out why the safety device was activated before resetting it. Under no circumstances can safety devices be bridged or changed to a value other than the factory setting. If the cause of the problem cannot be found, call your local dealer.
5. Verify all control connectors are securely seated in their respective connections.
6. Verify all fuses are not blown. If necessary, replace blown fuses.
7. Verify temperature sensors are reading properly using known temperatures and resistance measurements of the sensors. See Table for heat pump temperature sensors.

CAUTION

If the pressure relief valve is not working correctly and is to be replaced, ensure that the drain piping is properly reconnected.

Error Codes

Error Code	Description	Notes
C7	Transducer module temperature too high protection.	
E0	Water flow failure (E8 appears 3 times)	Verify circulator is operating and there is no air in the system
E1	Phase sequence error (for 3phase models)	Not applicable to the Eco™HP
E2	Communication error between the main control board of the hydraulic module and user interface	Verify wiring connections are secure between indoor unit control board and wired controller
E3	Backup electric heater exchanger water outlet temperature sensor T1 error	Not applicable to Eco™HP
E4	Domestic hot water tank temperature sensor T5 error	Not applicable to Eco™HP
E5	Air side heat exchanger refrigerant outlet temperature sensor T3 error	
E6	Outdoor ambient temperature sensor T4 error	
E7	Balance tank sensor Tbt1 error	Not applicable to Eco™HP
E8	Water flow failure within 3 times	Verify circulator is operating and there is no air in the system
E9	Suction pipe temperature sensor Th error	
EA	Discharge pipe temperature sensor Tp error	
Eb	Solar board sensor Tsolar error	Not applicable to Eco™HP
Ec	Balance tank sensor Tbt2 error	Not applicable to Eco™HP
Ed	Water side heat exchanger inlet temperature sensor Twin error	
EE	Hydronic box EEPROM error	
F1	DC generatrix voltage is too low	
H0	Communication error between outdoor unit main control chip and hydronic box main control chip	Verify wiring connections are secure between outdoor unit main control board and indoor unit main control board
H1	Communication error between outdoor unit main control chip and inverter driver chip	Verify wiring connections are secure between outdoor unit main control board and inverter driver board
H2	Water side heat exchanger refrigerant outlet (liquid pipe) temperature sensor T2 error	
H3	Water side heat exchanger refrigerant inlet (gas pipe) temperature sensor T2B error	
H4	Inverter module protection (L0/L1 appear 3 times in one hour)	
H5	Room temperature sensor Ta error	
H6	DC fan error	
H7	Abnormal main circuit voltage	Verify voltage to indoor unit is 120Vac and the outdoor unit is 240Vac
H8	Pressure sensor error	
H9	Zone 2 water outlet temperature sensor Tw2 error	
HA	Water side heat exchanger water outlet temperature sensor error	
Hb	PP protection appears three times in a row and Twout<44.6°F	
HF	Invert module EEPROM error	

Error Codes (continued)

Error Code	Description	Notes
HH	H6 appears 10 times in 120min	
HP	Low pressure protection (pressure < 0.6MPa for 3 times in one hour)	
P0	Low pressure protection	
P1	High pressure protection	
P3	Compressor current protection	
P4	Discharge temperature sensor Tp protection	
P5	High temperature difference between water side heat exchanger water inlet and water outlet temperatures protection	
P6	Inverter module protection	
L0	Inverter module protection	
L1	DC bus low voltage protection	
L2	DC bus high voltage protection	
L4	MCE error	
L5	Zero speed protection	
L7	Phase sequence error	Not applicable to Eco™HP
L8	Compressor frequency variation greater than 15Hz within one second protection	
L9	Actual compressor frequency differs from target frequency by more than 15Hz protection	
Pb	Water side heat exchanger anti-freeze protection	
Pd	Air side heat exchanger refrigerant outlet temperature sensor T3 error	
PP	Water side heat exchanger inlet temperature is higher than outlet temperature in heating/DHW mode	
bH	PED board error	

General Symptoms

Symptom 1: The unit is turned on but the unit is not heating or cooling as expected

POSSIBLE CAUSES	CORRECTIVE ACTION
The temperature setting is not correct.	Ensure all parameters listed in the application settings are set correctly.
The water flow is too low.	<ul style="list-style-type: none"> • Check that all shut off valves of the water circuit are in the right position. • Check if the strainer is plugged. • Make sure there is no air in the water system. • Check on the pressure and temperature gage that there is sufficient water pressure. The water pressure must be >14.5 PSI (water is cold). • Make sure that the expansion vessel is not broken. • Check that the resistance in the water circuit is not too high for the pump.
The water volume in the installation is too low.	Make sure that the water volume in the installation is above the minimum required value

Error Codes (continued)

Symptom 2: The unit is turned on but the compressor is not starting (space heating or domestic water heating)

POSSIBLE CAUSES	CORRECTIVE ACTION
The unit maybe operate out of its operation range (the water temperature is too low).	In case of low water temperature, the system utilizes the AHS to reach the minimum water temperature first (54 °F). <ul style="list-style-type: none"> • Verify AHS parameters are set correctly • Verify the boiler is called when AHS is activated

Symptom 3: Pump is making noise (cavitation)

POSSIBLE CAUSES	CORRECTIVE ACTION
There is air in the system.	Purge air.
Water pressure at pump inlet is too low.	<ul style="list-style-type: none"> • Check on the pressure and temperature gage that there is sufficient water pressure. The water pressure must be > 14.5 psi (water is cold). • Check that the pressure and temperature gage is not broken. • Check that the expansion vessel is not broken. • Check that the setting of the pre-pressure of the expansion vessel is correct.

Symptom 4: The water pressure relief valve opens

POSSIBLE CAUSES	CORRECTIVE ACTION
The expansion vessel is broken.	Replace the expansion vessel.
The filling water pressure in the installation is higher than 43.5 psi.	Make sure that the filling water pressure in the installation is about 12-15 psi.

Symptom 5: The water pressure relief valve leaks

POSSIBLE CAUSES	CORRECTIVE ACTION
Dirt is blocking the water pressure relief valve outlet.	<p>Check for correct operation of the pressure relief valve by activating the lever</p> <ul style="list-style-type: none"> • If you do not hear a clacking sound, contact your local dealer. • In case the water keeps running out of the unit, close both the water inlet and outlet shut-off valves first and then contact your local dealer.

Symptom 6: Space heating capacity shortage at low outdoor temperatures

POSSIBLE CAUSES	CORRECTIVE ACTION
AHS is not activated.	Ensure the AHS is on and configured to provide heat.



Error Codes (continued)

Symptom 7: Heat mode can't change to DHW mode immediately

POSSIBLE CAUSES	CORRECTIVE ACTION
The heat pump does not receive the control signal DHW=ON	Check whether there is a problem with the DHW wiring and whether the DHW=ON signal can be sent correctly.

Symptom 8: DHW mode can't change to Heat mode immediately

POSSIBLE CAUSES	CORRECTIVE ACTION
The heat pump did not receive the DHW shutdown signal.	Check that the tank controller can correctly send the DHW shutdown signal.



EcoCalc Value Records

	Parameter	Description	Priority 1	Priority 2	Priority 3
Boiler (System Type A)	WWSD Temp	Max outdoor temperature heating will operate			
	Outdoor Temperature Setpoint	Min outdoor temperature HP will operate			
	Target Crossover Temp	Max Target Temperature HP will operate			
	AHD Assign Contact	AHD Contact used for Priority			
	AHD Priority	Order AHD contact will activate, 1st (contacts close immediately with call for heat), 2nd (boiler fires first with call for heat), ODT (contact closes based on outdoor temperature setpoint and actions), Target Temp (contact closes based on system target temp and actions).			
	Response Time	Time to wait before performing the secondary activate contact action (e.g. if AHD closes first, will wait x minutes to activate boiler)			
	System Temp Dependent	If yes, system temperature must be below target temp before AHD contacts close			
	Activate contact below set point / above Crossover	"1st, 2nd, Emergency, or OFF -if limited by supply temp, set to 1st or Emergency -if limited by capacity, set to 1st (Boiler will run after response time has elapsed)"			
	Activate contact above set point / below Crossover	1st, 2nd, Emergency, or OFF (always set to 1st in Type A systems)			
	Max Target Temp	Max target water flow temperature			
	Min Target Temp	Min target water flow temperature			
	Outdoor Temp for Max Target	Outdoor temp for Max target water flow temp			
Outdoor Temp for Min Target	Outdoor temp for Min target water flow temp				
"Boiler (System Type B)	Enter any settings applied on System Type B boiler (outdoor reset, target temp, etc.)				
"Heat Pump (System Type A, B, or C)"	T4HMAX	"Max outdoor temperature HP heating will operate -if System Type A, this will be equal to the WWSD Temp"			
	T4HMIN	"Min outdoor temperature HP heating will operate -if system Type A and limited by supply temp, this will be equal to the Outdoor Temperature Setpoint -if system Type A and limited by capacity, this will be determined by the ECOCalc calculation to some temp below the ODT setpoint -if system Type B and limited by supply temp, this will be equal to T4_AHS_ON -if system Type B and limited by capacity, this will be determined by the ECOCalc calculation to some temp below T4_AHS_ON"			
	T1SetH1	Max target HP water flow temperature			
	T1SetH2	Min target HP water flow temperature			
	T4H1	Outdoor temp for Max target HP water flow temp			
	T4H2	Outdoor temp for Min target HP water flow temp			
	dT1SH	On differential for heating. The unit will not activate if the actual temp is less than dT1SH degrees below the target temp			
Heat Pump (System Type B)	T4_AHS_ON	Temperature HP will activate boiler, for Type B systems, usually equal to T4HMIN			
	dT1_AHS_ON	On differential for AHS. The AHS will not activate if the actual temp is less than dT1_AHS_ON degrees below the target temp. If dT1SH is greater than dT1_AHS_ON, then AHS will not turn on until the actual temp is dT1SH degrees below the target temp.			

