



# ULTRA<sup>®</sup>

Gas-Fired Water Boilers – Series 4  
Featuring **UControl**<sup>®</sup>

## Application Guide For Piping, Wiring & U-Control Setups



**⚠ WARNING**

This guide must only be used by a qualified heating installer/service technician. Read all instructions, including this Ultra boiler manual and all other information shipped with the boiler, before installing. Perform steps in the order given. Failure to comply could result in severe personal injury, death or substantial property damage.



# Read before proceeding

## Hazard definitions

The following defined terms are used throughout this manual to bring attention to the presence of hazards of various risk levels or to important information concerning the life of the product.

**⚠ DANGER** Indicates presence of hazards that will cause severe personal injury, death or substantial property damage.

**⚠ WARNING** Indicates presence of hazards that can cause severe personal injury, death or substantial property damage.

**⚠ CAUTION** Indicates presence of hazards that will or can cause minor personal injury or property damage.

**NOTICE** Indicates special instructions on installation, operation or maintenance that are important but not related to personal injury or property damage.

**NOTICE** This guide is meant to be used as a general guideline for piping and controlling Ultra Series 4 boilers in a variety of applications. Some installations can be piped in numerous other ways that will work equally as well as the suggestions here.

**NOTICE** Always follow recognized piping and control practices and all applicable codes. Provide and install all required controls on the boiler and system.

**NOTICE** See the Contents listing and the Application finder to select the system closest to your needs.

**NOTICE** Refer to the Ultra Boiler manual for details on expansion tank piping, relief valve piping and pipe sizing.

**⚠ WARNING** This guide provides application information only. It must be used only as a supplement to the Ultra Boiler manual and applicable code requirements. Follow all instructions in the Ultra Boiler manual for installation and start-up.



# Contents

<b>General piping requirements . . . . .</b>	<b>4</b>	<b>Application 13 . . . . .</b>	<b>.34</b>
The Ultra boiler must ALWAYS be piped in a secondary loop off of the primary loop		Single-zone BASEBOARD   DHW (System, as zone)	
<b>Weil-McLain Easy-Up® Manifold . . . . .</b>	<b>5</b>	<b>Application 14 . . . . .</b>	<b>.36</b>
Factory-built manifolds including near-boiler piping and system secondary connection		Multi-zone BASEBOARD (Zone valves)   Multi-zone RADIANT (Zone valves)   DHW (Direct-connected) (Radiant load must be <30% of total heat loss)	
<b>U-Control Screens . . . . .</b>	<b>6</b>	<b>Application 15 . . . . .</b>	<b>.38</b>
<b>U-Control menu access . . . . .</b>	<b>7</b>	Single-zone BASEBOARD   Single-zone RADIANT   POOL Heat exchanger (Radiant load must be <30% of total heat loss)	
BOILER SETTINGS   SYSTEM SETTINGS		<b>Application 16 . . . . .</b>	<b>.40</b>
<b>Application 1 . . . . .</b>	<b>8</b>	Single or Multi-zone SPACE HEATING   DHW (Direct-connected)   ISOLATION Heat exchanger (Tall buildings) (Use where space heating system operating pressure is over 25 PSIG)	
Single-zone BASEBOARD   DHW (Direct-connected)		<b>Multiple boiler operation options . . . . .</b>	<b>.42</b>
<b>Application 2 . . . . .</b>	<b>10</b>	Using the U-Control settings	
Single-zone FAN COIL(S)   DHW (Direct-connected)		<b>Application 17 — Multiple heat sources . . . . .</b>	<b>.44</b>
<b>Application 3 . . . . .</b>	<b>12</b>	ALTERNATIVE Heat source as primary / ULTRA as back-up   Single-zone BASEBOARD or FAN COIL — DHW (Direct-connected)	
Single-zone CAST IRON RADIATORS   DHW (Direct-connected)		<b>Application 17a — Multiple heat sources . . . . .</b>	<b>.46</b>
<b>Application 4 . . . . .</b>	<b>14</b>	NON-HYDRONIC PRIMARY Heat source as Type 1 (LEAD) / ULTRA as Type 2 (BACKUP) — Single-zone or multi-zone BASEBOARD or FAN COIL   DHW (Direct-connected)	
Multi-zone SPACE HEATING (Circulators + WMCR)   DHW (As zone in system)		<b>Application 18 — Multiple boilers . . . . .</b>	<b>.48</b>
<b>Application 5 . . . . .</b>	<b>16</b>	Multiple Ultra boilers   Multiple-zone SPACE HEATING (Circulators with WMCR)   DHW (Direct-connected)	
Multi-zone RADIANT   DHW (Direct-connected)   HEAT EXCHANGER (WMBP or WMPH) (<30% of total heat loss)		<b>Application 19 — Multiple boilers . . . . .</b>	<b>.52</b>
<b>Application 6 . . . . .</b>	<b>18</b>	Multiple Ultra boilers   Multi-zone SPACE HEATING & DHW (In system) (Circulators with WMCR controllers)	
Multi-zone RADIANT   DHW (Direct-connected)   Small BASEBOARD zone (<30% of total heat loss)		<b>Application 20 — Multiple boilers . . . . .</b>	<b>.56</b>
<b>Application 7 . . . . .</b>	<b>20</b>	Multiple Ultra boilers   Multiple loads on SECONDARY loops   DHW (Direct-connected)	
Multiple HI-TEMP HEATING zones   DHW (Direct-connected)   Small RADIANT zone (<30 of total heat loss)		<b>Application 21 — Multiple boilers . . . . .</b>	<b>.60</b>
<b>Application 7a . . . . .</b>	<b>22</b>	BASE LOADING with ULTRA boilers   DHW (Direct connected)	
Multi-zone HI-TEMP HEATING plus RADIANT (with mixing valve)   DHW (Direct-connected) (No limits on the relative heating loads of radiant or hi-temp space heating circuits)		<b>Appendix A . . . . .</b>	<b>.64</b>
<b>Application 8 . . . . .</b>	<b>24</b>	OUTDOOR RESET Settings and Troubleshooting	
Multi-zone BASEBOARD (Zone valves + WMZV controller)   DHW (Direct-connected)		<b>Appendix B . . . . .</b>	<b>.65</b>
<b>Application 9 . . . . .</b>	<b>26</b>	BOILER SETTINGS menu detail	
Multi-zone BASEBOARD (Circulators + WMCR controller)   DHW (Direct-connected)		<b>Appendix C . . . . .</b>	<b>.66</b>
<b>Application 10 . . . . .</b>	<b>28</b>	SYSTEM SETTINGS menu detail	
Multi-zone FAN COILS (Circs. + WMCR contr.)   DHW (Direct-connected)   Small RADIANT zone (<30% of total heat loss)			
<b>Application 11 . . . . .</b>	<b>30</b>		
CAST IRON RADIATORS   DHW (Direct-connected)   Small RADIANT zone (<30% of total heat loss)			
<b>Application 12 . . . . .</b>	<b>32</b>		
FAN COIL zone   BASEBOARD zone   Small RADIANT zone (<30% of total heat loss)			



# General piping requirements

The Ultra boiler must ALWAYS be piped in a secondary loop off of the primary loop

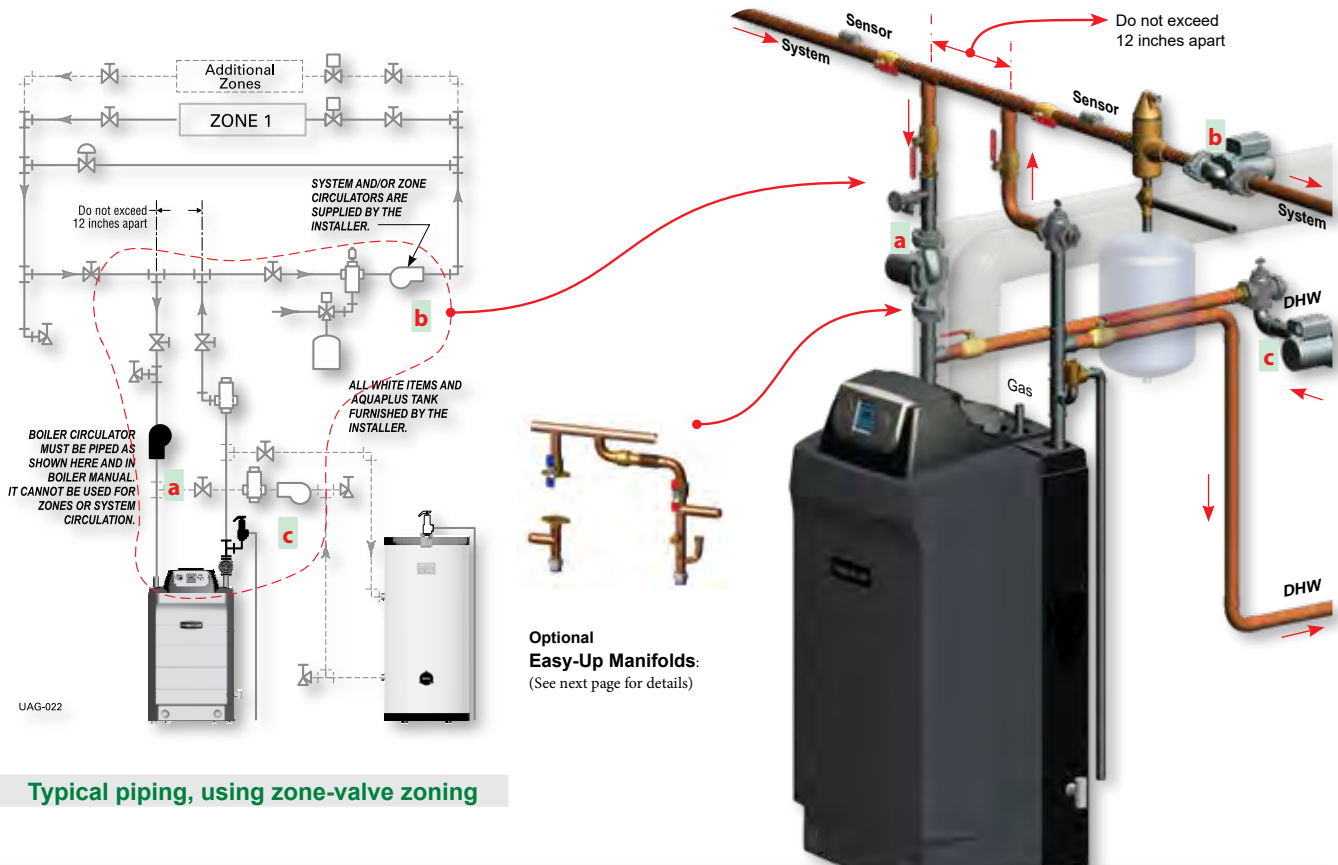

Typical piping, using zone-valve zoning

The circulator supplied with the boiler (a) must be used only in the boiler secondary loop as shown in the schematic above and in the manual. System (b) and zone circulators and DHW circulator (c) must be supplied by the installer. Above right is a typical installation, showing the near-boiler piping and connection to the system.

Boiler loop piping must be sized to the minimums listed in the boiler manual. Using smaller piping will cause performance problems.

- Ultra-80 / Ultra-105 . . . . . use 1" or larger
- Ultra-155 / Ultra-230 . . . . . use 1¼" or larger
- Ultra-299 / Ultra-399 . . . . . use 1½" or larger

**RIGHT**

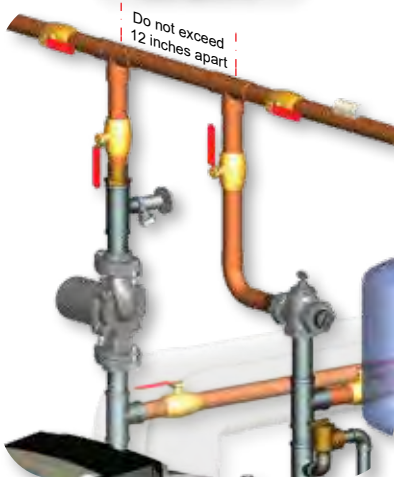

## INSTALLING THE PRIMARY/SECONDARY TEES

The near-boiler piping must be primary/secondary as shown above and left, with the boiler loop piping entering the tees in the branch connection. DO NOT connect boiler piping to the tee through connections as shown at right. The system will not work correctly this way.

**WRONG**

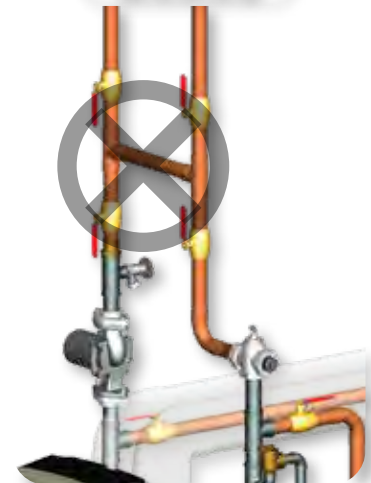



# Weil-McLain Easy-Up® Manifold

Factory-built manifolds including near-boiler piping and system secondary connection

<b>NOTICE</b>	To ensure proper system operation, install <b>system headers</b> sized to the guidelines at right:	Ultra-80 . . . . . 1" or larger
		Ultra-105, -155 . . . . . 1¼" or larger
		Ultra-230 . . . . . 1½" or larger
		Ultra-299, -399 . . . . . 2" or larger

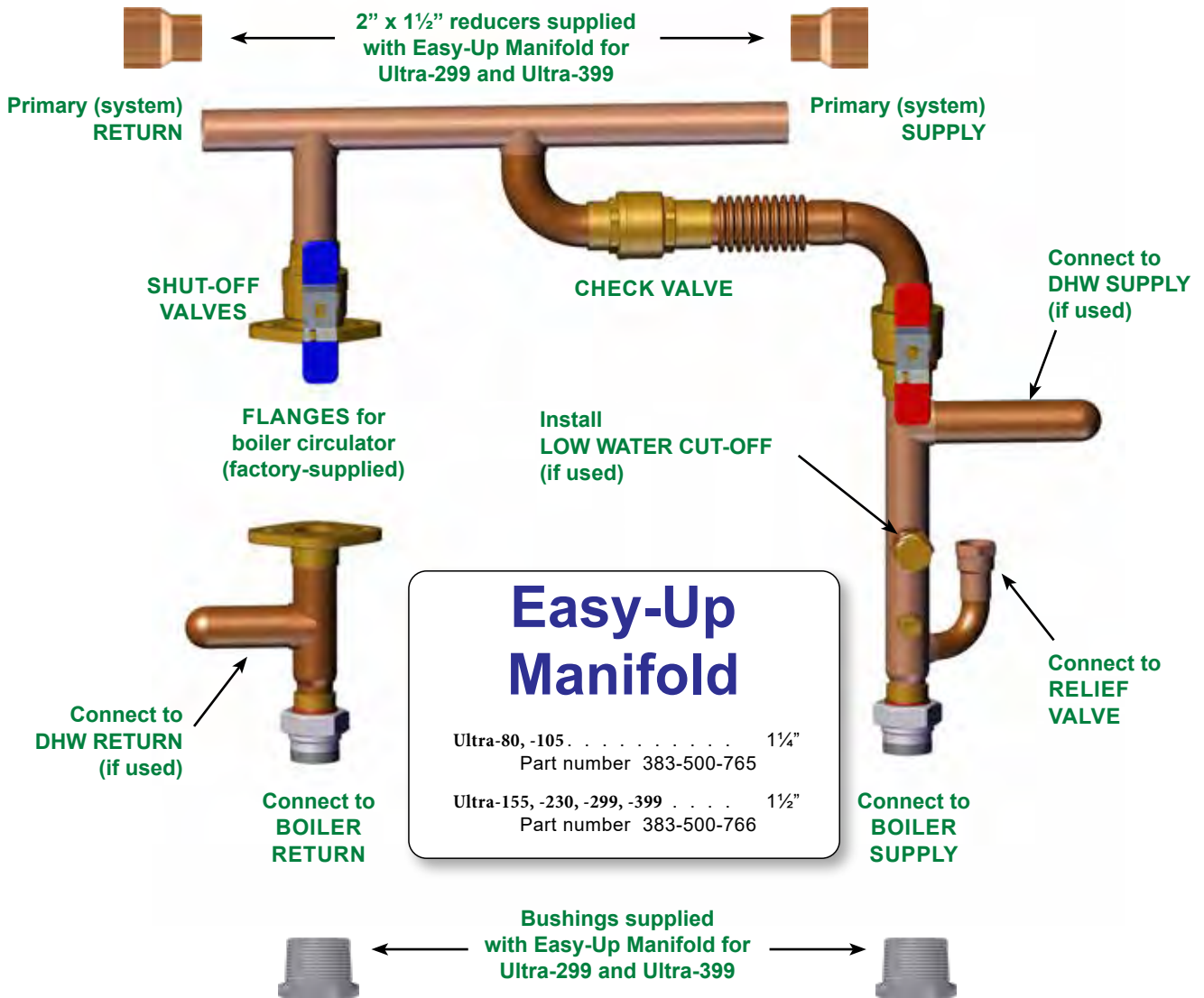

**⚠ WARNING** Follow all instructions in the Easy-Up Manifold Instructions supplied with the kit. Failure to follow instructions could result in severe personal injury, death or substantial property damage.



## U-Control Screens

**NOTICE** See individual application instructions for required and optional control settings using the BOILER SETTINGS and SYSTEM SETTINGS menus. See Appendices for additional menu details.





# U-Control menu access

BOILER SETTINGS | SYSTEM SETTINGS

**NOTICE** See individual application instructions for required and optional control settings using the BOILER SETTINGS and SYSTEM SETTINGS menus. See Appendices for additional menu details.

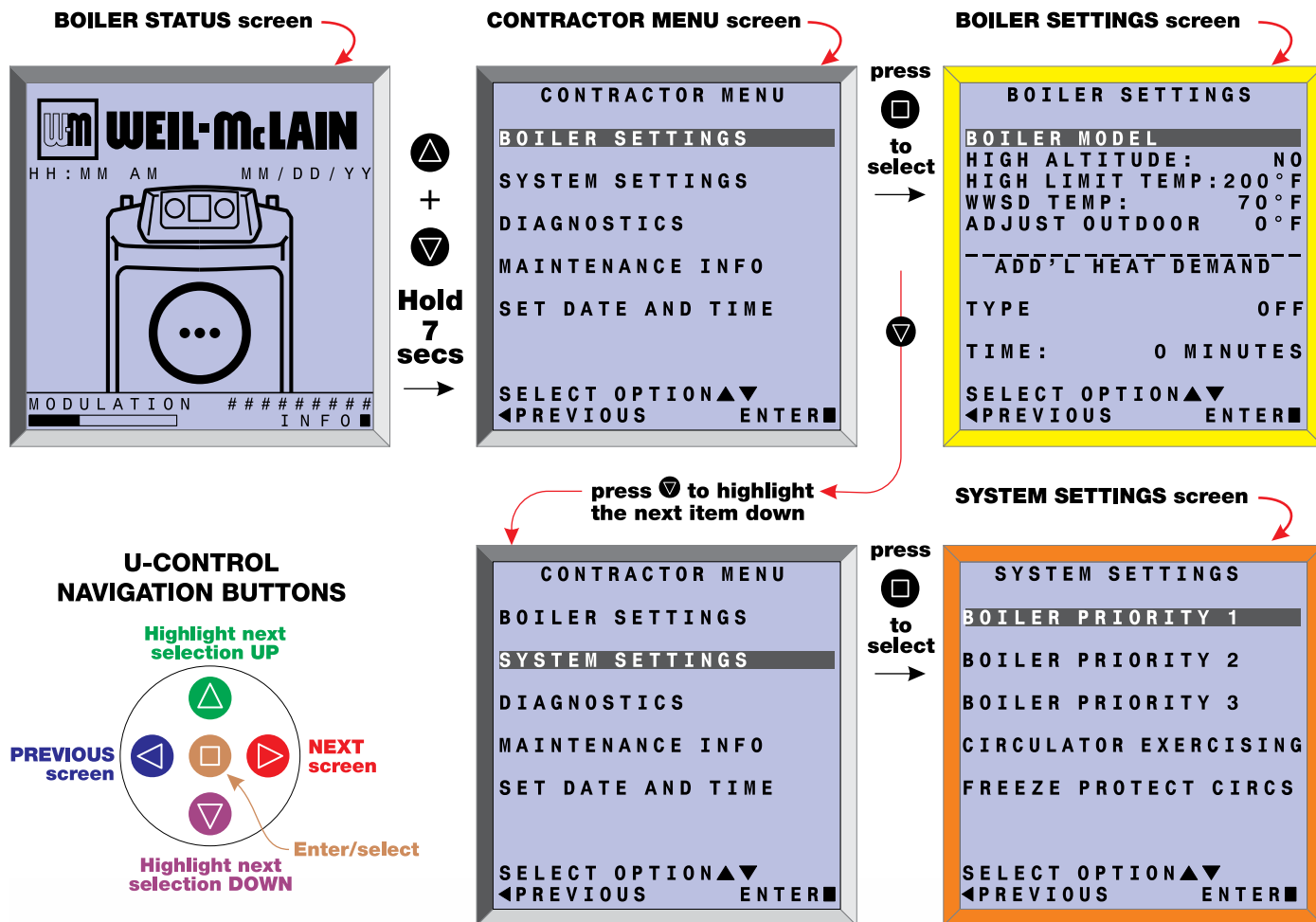



# Application 1

Single-zone BASEBOARD | DHW (Direct-connected)

## Purpose

- Space heating with finned tube or cast iron baseboard, plus DHW supplied by a single boiler.
- DHW priority — space heating is disabled during call for heat from water heater.

## U-Control settings

- See the table at right for required and optional settings.
- To see the navigation sequence to access the BOILER SETTINGS and SYSTEM SETTINGS menus, see page 7.
- Select DHW DIRECT for the DHW BOILER PRIORITY 1. This informs the control that the DHW tank is directly connected to the boiler.

## Circulators and piping

- Piping must be primary/secondary as shown, with the boiler piped in a secondary loop and the DHW piped to the boiler loop.

### DHW

- DHW circulator must be selected to handle the pressure drop through the Ultra boiler, water heater and piping — see boiler manual for recommended sizing. DHW circulator supplied by installer.
- For some large indirect water heaters, the required flow rate may require piping the water heater differently — see boiler manual and other applications in this guide.
- U-Control is set for DHW priority — space heating will be discontinued during a call for DHW.

### BASEBOARD system

- Size for required flow.
- System circulator supplied by installer.
- Single zone only (see other applications in this guide for zoning)
- Piping can be one-pipe or two-pipe (provide balancing valves if needed).
- U-Control is set for DHW priority — space heating will be discontinued during a call for DHW.

### BOILER

- Circulator shipped loose with boiler.
- Boiler loop piping can be provided using optional Easy-Up Manifolds, available from Weil-McLain (see page 5).

## Wiring

- Connect field wiring as shown on next page.
- This application applies only to single-zone space heating — see other applications in this guide for multiple-zone systems.
- For circulators connected to the U-Control, the maximum circulator load is 2.2 amps each — if load is higher, provide a circulator relay or contactor for circulator power.

<b>U-CONTROL SETTINGS</b> (SEE NAVIGATION FLOW BELOW)			
	<b>XXX</b>	— VALUE MUST BE SET (OR VERIFIED) AS INDICATED	
	<b>D</b>	— DEFAULT ACCEPTABLE; CHANGE ONLY IF DESIRED	
<b>BOILER SETTINGS</b>			
BOILER MODEL		Verify model number is correct	
HIGH ALTITUDE		Set to YES if high altitude	
HIGH LIMIT		D	
WWSD TEMP		DEFAULT (70 °F) OR AS REQUIRED	
ADJUST OUTDOOR		DEFAULT (0 °F) OR AS REQUIRED	
ADD'L HEAT DEMAND TYPE		D	
ADD'L HEAT DEMAND TIME		D	
<b>SYSTEM SETTINGS</b>			
<b>BOILER PRIORITY 1 DHW</b>	SYSTEM TYPE	Select from list	<b>DHW DIRECT</b>
	TEMPERATURES	Max Supply	<b>190 F</b>
		Max OD Reset	D
		Min OD Reset	D
		Modulate On Diff	D
	TIMES	Modulate Off Diff	D
		Max On Time	D
		Boost Interval Prepump Time: Postpump Time:	D D D
	CIRCULATORS	Circulator 1 Circulator 2 Circulator 3	<b>ON</b> <b>OFF</b> <b>OFF</b>
	MAXIMUM RATE		D
MINIMUM RATE		D	
<b>BOILER PRIORITY 2 Baseboard (Finned tube or cast iron)</b>	SYSTEM TYPE	Select from list	<b>FTB or CIB</b>
	TEMPERATURES	Max Supply	<b>180 F</b>
		Min Supply	D
		Max OD Reset	<b>D (70F) or as req'd</b>
		Min OD Reset	<b>D (0F) or as req'd</b>
	TIMES	Modulate On Diff	D
		Modulate Off Diff	D
		Max On Time Min On Time Boost Interval Prepump Time: Postpump Time:	D D D D D
	CIRCULATORS	Circulator 1 Circulator 2 Circulator 3	<b>OFF</b> <b>ON</b> <b>ON</b>
	MAXIMUM RATE		D
MINIMUM RATE		D	
<b>BOILER PRIORITY 3 Not used</b>	SYSTEM TYPE	Select from list	D
	TEMPERATURES	Max Supply	D
		Min Supply	D
		Max OD Reset	D
		Min OD Reset	D
	TIMES	Modulate On Diff	D
		Modulate Off Diff	D
		Min On Time Boost Interval Prepump Time: Postpump Time:	D D D D
	CIRCULATORS	Circulator 1 Circulator 2 Circulator 3	D D D
	MAXIMUM RATE		D
MINIMUM RATE		D	
CIRCULATOR EXERCISING	Circulator 1 Circulator 2 Circulator 3	D D D	
FREEZE PROTECT CIRC'S	Circulator 1 Circulator 2 Circulator 3	D D D	





## PIPING

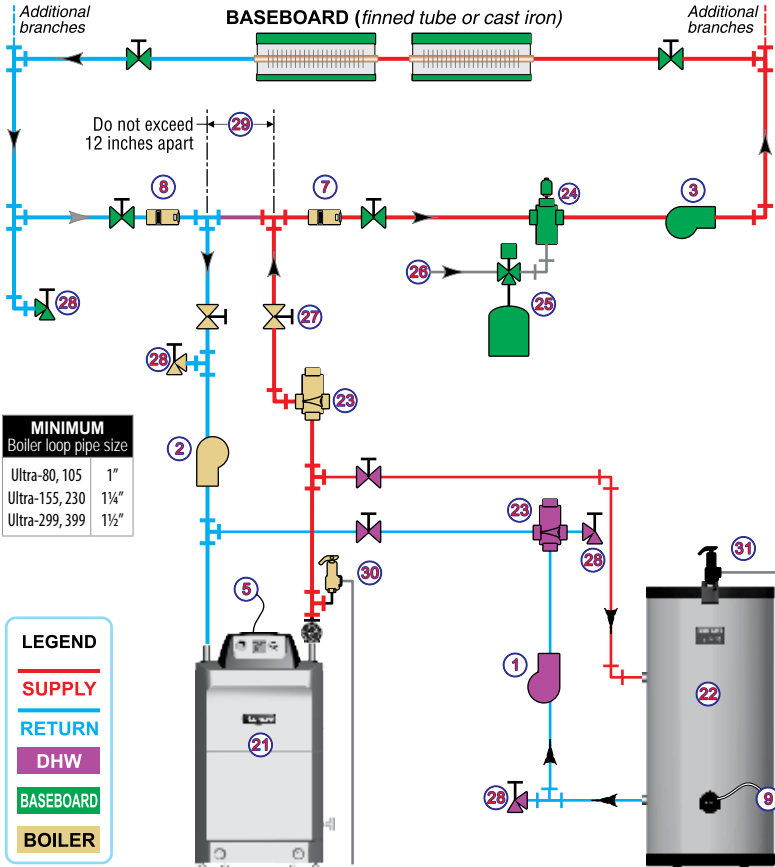

## LEGEND

\* = Supplied by installer

- 1 DHW circulator \*
- 2 BOILER circulator (shipped loose with boiler)
- 3 SYSTEM circulator \*
- 4 120VAC power supply, 15-amp minimum rating
- 5 U-Control
- 6 House thermostat \*
- 7 Supply temperature sensor — strap to supply line
- 8 Return temperature sensor — strap to return line
- 9 DHW tank aquastat or sensor\*
- 10 Outdoor temperature sensor (supplied with boiler; install if U-Control will be set for outdoor reset operation)
- 11 Low water cutoff (if used) \*
- 21 Ultra boiler
- 22 Indirect water heater \*
- 23 Flow/check valves \*
- 24 Air separator with automatic air vent \*
- 25 Diaphragm-type expansion tank \*
- 26 Fresh water supply — install per applicable codes \*
- 27 Isolation valves \*
- 28 Purge/drain valves \*
- 29 Secondary piping connection for boiler loop \*
- 30 Boiler relief valve (install per boiler manual)
- 31 DHW Temperature and Pressure relief valve (install per boiler manual)

## FIELD WIRING

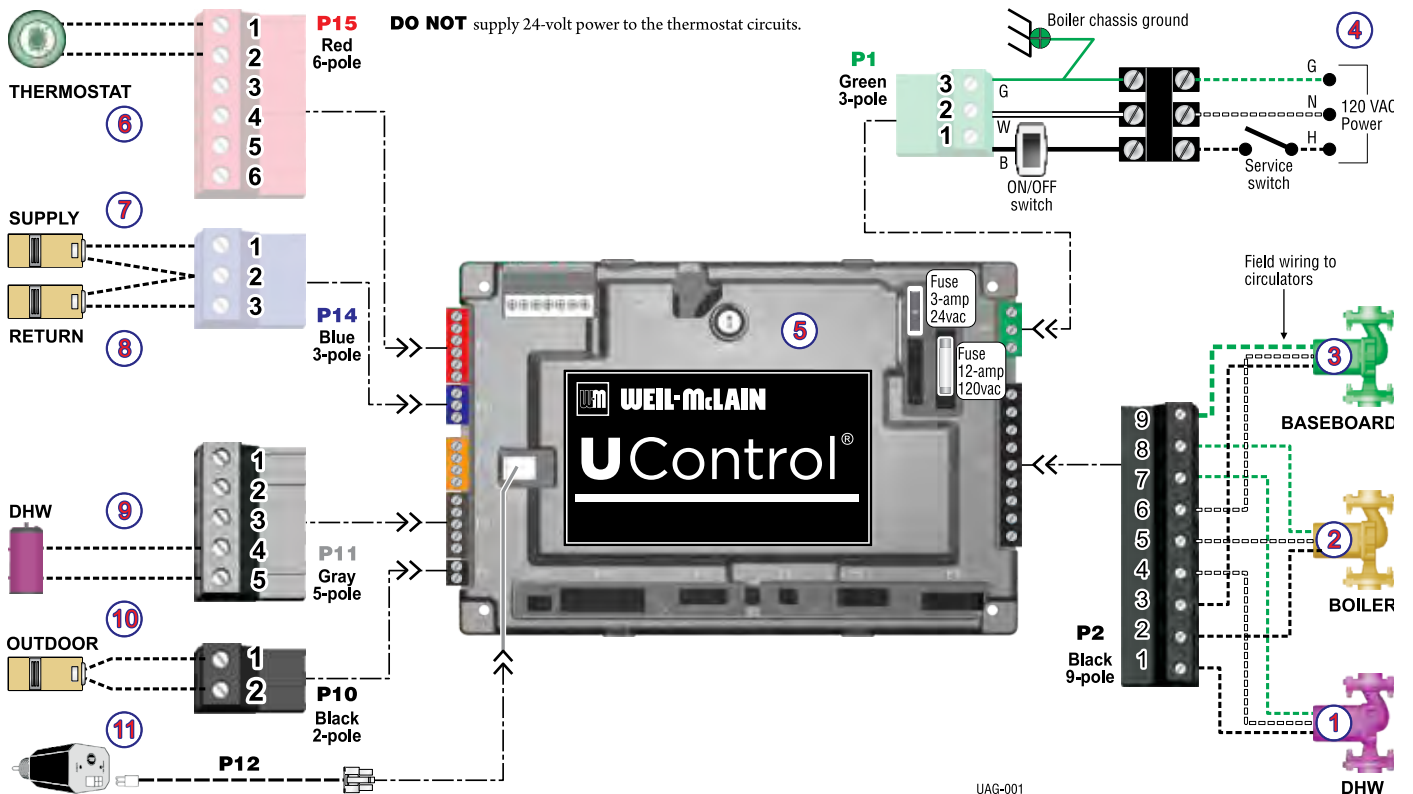



# Application 2

Single-zone **FAN COIL(S)** | DHW (Direct-connected)

## Purpose

- Space heating with fan coil(s) and DHW supplied by a single boiler.
- DHW priority — space heating is disabled during call for heat from water heater.

## U-Control settings

- See the table at right for required and optional settings.
- To see the navigation sequence to access the BOILER SETTINGS and SYSTEM SETTINGS menus, see page 7.
- Select DHW DIRECT for the DHW BOILER PRIORITY 1. This informs the control that the DHW tank is directly connected to the boiler.

## Circulators and piping

- Piping must be primary/secondary as shown, with the boiler piped in a secondary loop and the DHW piped to the boiler loop.

### DHW

- DHW circulator must be selected to handle the pressure drop through the Ultra boiler, water heater and piping — see boiler manual for recommended sizing. DHW circulator supplied by installer.
- For some large indirect water heaters, the required flow rate may require piping the water heater differently — see boiler manual and other applications in this guide.
- U-Control is set for DHW priority — space heating will be discontinued during a call for DHW.

### FAN COIL system

- Size for required flow.
- System circulator supplied by installer.
- Single zone only (see other applications in this guide for zoning)
- Piping can be one-pipe or two-pipe (provide balancing valves if needed).
- U-Control is set for DHW priority — space heating will be discontinued during a call for DHW.

### BOILER

- See boiler manual for sizing.
- Circulator shipped loose with boiler.
- Boiler loop piping can be provided using optional Easy-Up Manifolds, available from Weil-McLain (see page 5).

## Wiring

- Connect field wiring as shown on next page.
- This application applies only to single-zone space heating — see other applications in this guide for multiple-zone systems.
- For circulators connected to the U-Control, the maximum circulator load is 2.2 amps each — if load is higher, provide a circulator relay or contactor for circulator power.

<b>U-CONTROL SETTINGS</b> (SEE NAVIGATION FLOW BELOW)			
	<b>XXX</b>	— VALUE MUST BE SET (OR VERIFIED) AS INDICATED	
	<b>D</b>	— DEFAULT ACCEPTABLE; CHANGE ONLY IF DESIRED	
<b>BOILER SETTINGS</b>			
BOILER MODEL		Verify model number is correct	
HIGH ALTITUDE		Set to YES if high altitude	
HIGH LIMIT		D	
WWSD TEMP		DEFAULT (70 °F) OR AS REQUIRED	
ADJUST OUTDOOR		DEFAULT (0 °F) OR AS REQUIRED	
ADD'L HEAT DEMAND TYPE		D	
ADD'L HEAT DEMAND TIME		D	
<b>SYSTEM SETTINGS</b>			
<b>BOILER PRIORITY 1 DHW</b>	SYSTEM TYPE	Select from list	<b>DHW DIRECT</b>
	TEMPERATURES	Max Supply	<b>190 F</b>
		Max OD Reset	D
		Min OD Reset	D
		Modulate On Diff	D
	TIMES	Modulate Off Diff	D
		Max On Time	D
		Boost Interval Prepump Time: Postpump Time:	D D D
	CIRCULATORS	Circulator 1	<b>ON</b>
		Circulator 2	<b>OFF</b>
Circulator 3		<b>OFF</b>	
MAXIMUM RATE		D	
MINIMUM RATE		D	
<b>BOILER PRIORITY 2 Fan coils</b>	SYSTEM TYPE	Select from list	<b>FCL</b>
	TEMPERATURES	Max Supply	<b>190 F</b>
		Min Supply	D
		Max OD Reset	<b>D (70F) or as req'd</b>
		Min OD Reset	<b>D (0F) or as req'd</b>
	TIMES	Modulate On Diff	D
		Modulate Off Diff	D
		Max On Time Min On Time Boost Interval Prepump Time: Postpump Time:	D D D D D
	CIRCULATORS	Circulator 1	<b>OFF</b>
		Circulator 2	<b>ON</b>
Circulator 3		<b>ON</b>	
MAXIMUM RATE		D	
MINIMUM RATE		D	
<b>BOILER PRIORITY 3 Not used</b>	SYSTEM TYPE	Select from list	D
	TEMPERATURES	Max Supply	D
		Min Supply	D
		Max OD Reset	D
		Min OD Reset	D
	TIMES	Modulate On Diff	D
		Modulate Off Diff	D
		Min On Time Boost Interval Prepump Time: Postpump Time:	D D D D
	CIRCULATORS	Circulator 1	D
		Circulator 2	D
Circulator 3		D	
MAXIMUM RATE		D	
MINIMUM RATE		D	
<b>CIRCULATOR EXERCISING</b>	Circulator 1	D	
	Circulator 2	D	
	Circulator 3	D	
<b>FREEZE PROTECT CIRC'S</b>	Circulator 1	D	
	Circulator 2	D	
	Circulator 3	D	



## PIPING

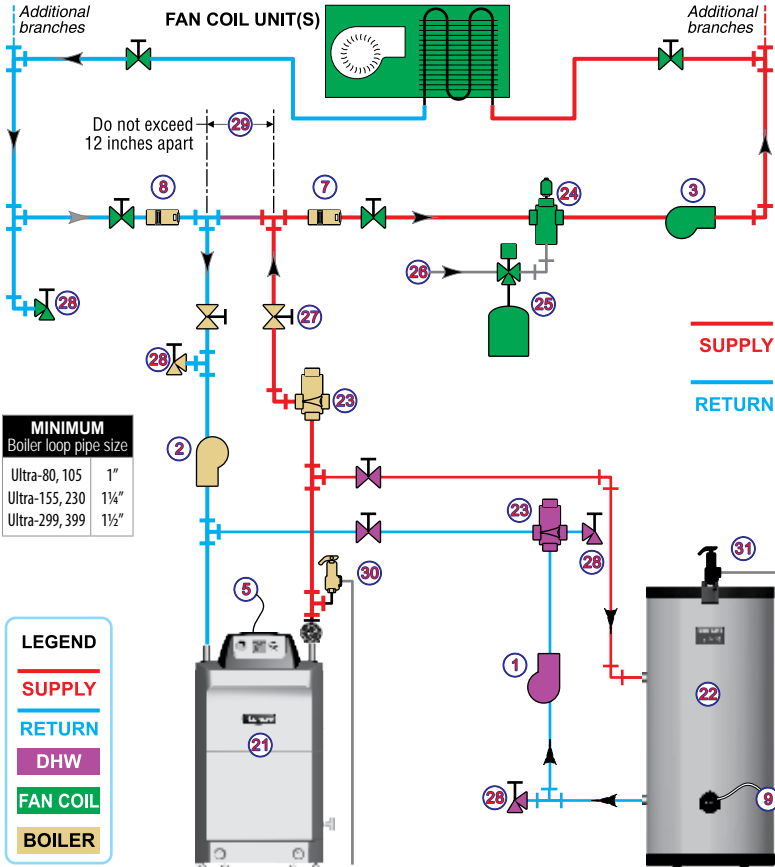

## LEGEND

\* = Supplied by installer

- DHW circulator \*
- BOILER circulator (shipped loose with boiler)
- SYSTEM circulator \*
- 120VAC power supply, 15-amp minimum rating
- U-Control
- House thermostat \*
- Supply temperature sensor — strap to supply line
- Return temperature sensor — strap to return line
- DHW tank aquastat or sensor \*
- Outdoor temperature sensor (supplied with boiler; install if U-Control will be set for outdoor reset operation)
- Low water cutoff (if used) \*
- Ultra boiler
- Indirect water heater \*
- Flow/check valves \*
- Air separator with automatic air vent \*
- Diaphragm-type expansion tank \*
- Fresh water supply — install per applicable codes \*
- Isolation valves \*
- Purge/drain valves \*
- Secondary piping connection for boiler loop \*
- Boiler relief valve (install per boiler manual)
- DHW Temperature and Pressure relief valve (install per boiler manual)

## FIELD WIRING

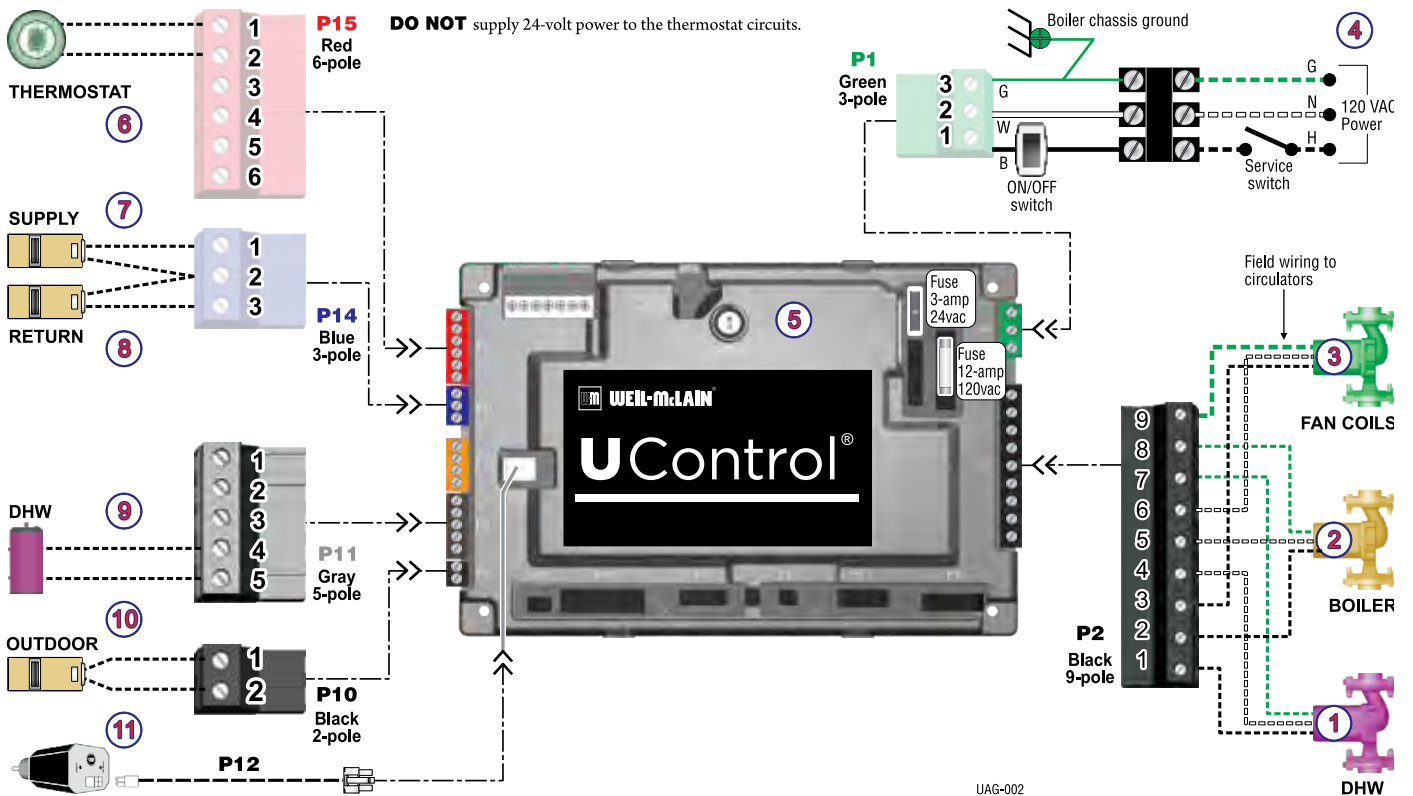



# Application 3

## Single-zone CAST IRON RADIATORS | DHW (Direct-connected)

### Purpose

- Space heating with cast iron radiators and DHW supplied by a single boiler.
- DHW priority — space heating is disabled during call for heat from water heater.

### U-Control settings

- See the table at right for required and optional settings.
- To see the navigation sequence to access the BOILER SETTINGS and SYSTEM SETTINGS menus, see page 7.
- Select DHW DIRECT for the DHW BOILER PRIORITY 1. This informs the control that the DHW tank is directly connected to the boiler.

### Circulators and piping

- Piping must be primary/secondary as shown, with the boiler piped in a secondary loop and the DHW piped to the boiler loop.

#### DHW

- DHW circulator must be selected to handle the pressure drop through the Ultra boiler, water heater and piping — see boiler manual for recommended sizing. DHW circulator supplied by installer.
- For some large indirect water heaters, the required flow rate may require piping the water heater differently — see boiler manual and other applications in this guide.
- U-Control is set for DHW priority — space heating will be discontinued during a call for DHW.

#### RADIATOR system

- Size for required flow.
- System circulator supplied by installer.
- Single zone only (see other applications in this guide for zoning)
- Piping can be one-pipe or two-pipe (provide balancing valves if needed).
- U-Control is set for DHW priority — space heating will be discontinued during a call for DHW.

#### BOILER

- See boiler manual for sizing.
- Circulator shipped loose with boiler.
- Boiler loop piping can be provided using optional Easy-Up Manifolds, available from Weil-McLain (see page 5).

### Wiring

- Connect field wiring as shown on next page.
- This application applies only to single-zone space heating — see other applications in this guide for multiple-zone systems.
- For circulators connected to the U-Control, the maximum circulator load is 2.2 amps each — if load is higher, provide a circulator relay or contactor for circulator power.

<b>U-CONTROL SETTINGS</b> (SEE NAVIGATION FLOW BELOW)			
	<b>XXX</b>	— VALUE MUST BE SET (OR VERIFIED) AS INDICATED	
	<b>D</b>	— DEFAULT ACCEPTABLE; CHANGE ONLY IF DESIRED	
<b>BOILER SETTINGS</b>			
BOILER MODEL		Verify model number is correct	
HIGH ALTITUDE		Set to YES if high altitude	
HIGH LIMIT		D	
WWSD TEMP		DEFAULT (70 °F) OR AS REQUIRED	
ADJUST OUTDOOR		DEFAULT (0 °F) OR AS REQUIRED	
ADD'L HEAT DEMAND TYPE		D	
ADD'L HEAT DEMAND TIME		D	
<b>SYSTEM SETTINGS</b>			
<b>BOILER PRIORITY 1 DHW</b>	SYSTEM TYPE	Select from list	<b>DHW DIRECT</b>
	TEMPERATURES	Max Supply	<b>190 F</b>
		Max OD Reset	D
		Min OD Reset	D
		Modulate On Diff	D
	TIMES	Modulate Off Diff	D
		Max On Time	D
		Boost Interval Prepump Time: Postpump Time:	D D D
	CIRCULATORS	Circulator 1	<b>ON</b>
		Circulator 2	<b>OFF</b>
Circulator 3		<b>OFF</b>	
MAXIMUM RATE		D	
MINIMUM RATE		D	
<b>BOILER PRIORITY 2 Radiators</b>	SYSTEM TYPE	Select from list	<b>CIR</b>
	TEMPERATURES	Max Supply	<b>180 F</b>
		Min Supply	D
		Max OD Reset	<b>D (70F) or as req'd</b>
		Min OD Reset	<b>D (0F) or as req'd</b>
	TIMES	Modulate On Diff	D
		Modulate Off Diff	D
		Max On Time Min On Time Boost Interval Prepump Time: Postpump Time:	D D D D D
	CIRCULATORS	Circulator 1	<b>OFF</b>
		Circulator 2	<b>ON</b>
Circulator 3		<b>ON</b>	
MAXIMUM RATE		D	
MINIMUM RATE		D	
<b>BOILER PRIORITY 3 Not used</b>	SYSTEM TYPE	Select from list	D
	TEMPERATURES	Max Supply	D
		Min Supply	D
		Max OD Reset	D
		Min OD Reset	D
	TIMES	Modulate On Diff	D
		Modulate Off Diff	D
		Min On Time Boost Interval Prepump Time: Postpump Time:	D D D D
	CIRCULATORS	Circulator 1	D
		Circulator 2	D
Circulator 3		D	
MAXIMUM RATE		D	
MINIMUM RATE		D	
<b>CIRCULATOR EXERCISING</b>	Circulator 1	D	
	Circulator 2	D	
	Circulator 3	D	
<b>FREEZE PROTECT CIRC'S</b>	Circulator 1	D	
	Circulator 2	D	
	Circulator 3	D	



## PIPING

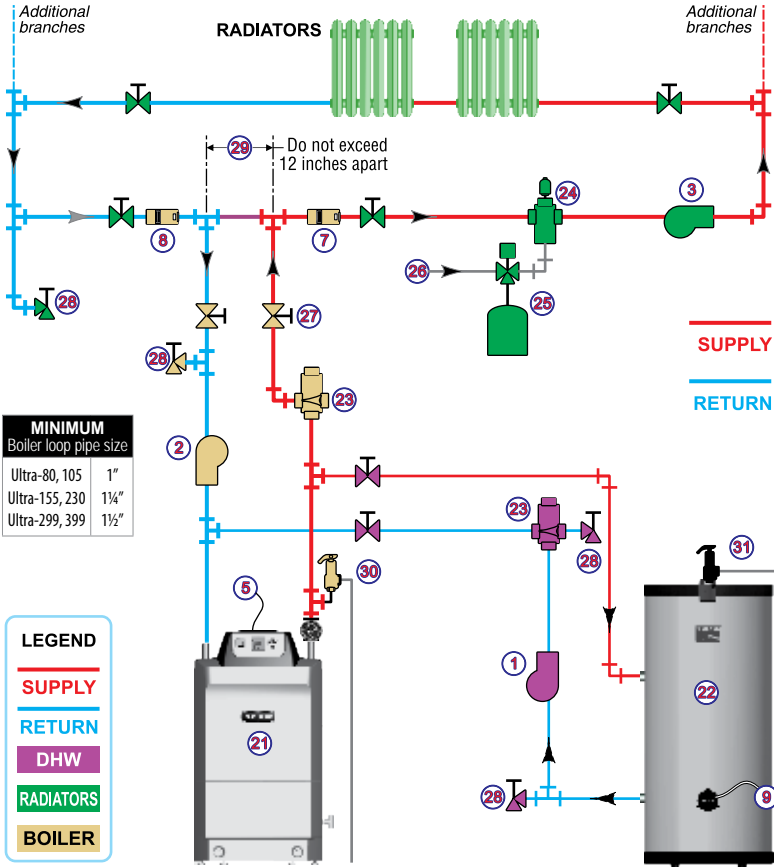

## LEGEND

\* = Supplied by installer

- DHW circulator \*
- BOILER circulator (shipped loose with boiler)
- SYSTEM circulator \*
- 120VAC power supply, 15-amp minimum rating
- U-Control
- House thermostat \*
- Supply temperature sensor — strap to supply line
- Return temperature sensor — strap to return line
- DHW tank aquastat or sensor \*
- Outdoor temperature sensor (supplied with boiler; install if U-Control will be set for outdoor reset operation)
- Low water cutoff (if used) \*
- Ultra boiler
- Indirect water heater \*
- Flow/check valves \*
- Air separator with automatic air vent \*
- Diaphragm-type expansion tank \*
- Fresh water supply — install per applicable codes \*
- Isolation valves \*
- Purge/drain valves \*
- Secondary piping connection for boiler loop \*
- Boiler relief valve (install per boiler manual)
- DHW Temperature and Pressure relief valve (install per boiler manual)

## FIELD WIRING

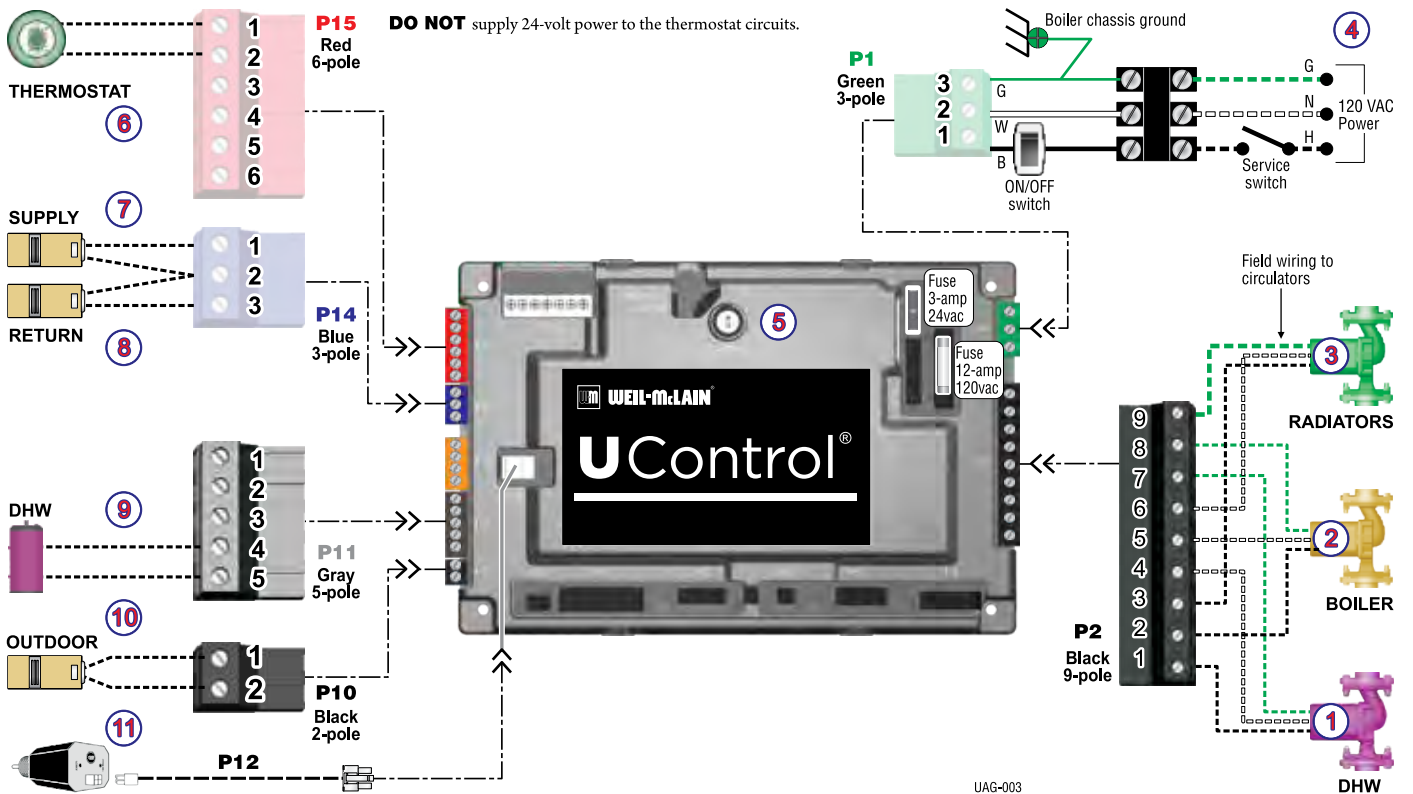



# Application 4

Multi-zone **SPACE HEATING** (Circulators + WMCR) | DHW (As zone in system)

## Purpose

- Space heating with multiple zones. This system is applicable to any terminal unit type, including radiant.
- Zoning with circulators.
- DHW piped as a separate zone.
- DHW priority — space heating is disabled during call for heat from water heater.

## U-Control settings

- See the table at right for required and optional settings.
- To see the navigation sequence to access the BOILER SETTINGS and SYSTEM SETTINGS menus, see page 7.
- Select DHW SYSTEM for the DHW BOILER PRIORITY 1. This informs the control that the DHW tank is a system zone, not directly connected to the boiler.

## Circulators and piping

- Piping must be primary/secondary as shown.

### DHW

- DHW circulator must be sized for required flow and head loss.
- DHW circulator supplied by installer.
- U-Control is set for DHW priority — space heating will be discontinued during a call for DHW.

### SPACE HEATING

- Multiple zones
- Size circulators for required flow.
- Space heating circulators supplied by installer.
- Circulators controlled by a circulator zone controller.

### BOILER

- See boiler manual for sizing.
- Circulator shipped loose with boiler.
- Boiler loop piping can be provided using optional Easy-Up Manifolds, available from Weil-McLain (see page 5).

## Wiring

- Connect field wiring as shown on next page.
- This application applies only to multiple-zone space heating, using a zone controller.
- For circulators connected to the U-Control, the maximum circulator load is 2.2 amps each — if load is higher, provide a circulator relay or contactor for circulator power.

<b>U-CONTROL SETTINGS</b> (SEE NAVIGATION FLOW BELOW)				
	<b>XXX</b>	— VALUE MUST BE SET (OR VERIFIED) AS INDICATED		
	<b>D</b>	— DEFAULT ACCEPTABLE; CHANGE ONLY IF DESIRED		
<b>BOILER SETTINGS</b>				
BOILER MODEL		Verify model number is correct		
HIGH ALTITUDE		Set to YES if high altitude		
HIGH LIMIT		D		
WWSD TEMP		DEFAULT (70 °F) OR AS REQUIRED		
ADJUST OUTDOOR		DEFAULT (0 °F) OR AS REQUIRED		
ADD'L HEAT DEMAND TYPE		D		
ADD'L HEAT DEMAND TIME		D		
<b>SYSTEM SETTINGS</b>				
<b>BOILER PRIORITY 1 DHW</b>	SYSTEM TYPE	Select from list	DHW SYSTEM	
		Max Supply	190 F	
	TEMPERATURES	Max OD Reset		D
		Min OD Reset		D
		Modulate On Diff		D
		Modulate Off Diff		D
	TIMES	Max On Time		D
		Boost Interval		D
		Prepump Time: Postpump Time:		D
	CIRCULATORS	Circulator 1		ON
Circulator 2			ON	
Circulator 3			OFF	
MAXIMUM RATE			D	
MINIMUM RATE			D	
<b>BOILER PRIORITY 2 Space heating (any type)</b>	SYSTEM TYPE	Select from list	Select type used	
	TEMPERATURES	Max Supply		As req'd
		Min Supply		D
		Max OD Reset		D (70F) or as req'd
		Min OD Reset		D (0F) or as req'd
		Modulate On Diff		D
		Modulate Off Diff		D
	TIMES	Max On Time		D
		Min On Time		D
		Boost Interval		D
Prepump Time: Postpump Time:			D	
			D	
CIRCULATORS	Circulator 1		OFF	
	Circulator 2		ON	
	Circulator 3		OFF	
MAXIMUM RATE			D	
MINIMUM RATE			D	
<b>BOILER PRIORITY 3 Not used</b>	SYSTEM TYPE	Select from list	D	
	TEMPERATURES	Max Supply		D
		Min Supply		D
		Max OD Reset		D
		Min OD Reset		D
		Modulate On Diff		D
		Modulate Off Diff		D
	TIMES	Min On Time		D
		Boost Interval		D
		Prepump Time: Postpump Time:		D
			D	
			D	
CIRCULATORS	Circulator 1		D	
	Circulator 2		D	
	Circulator 3		D	
MAXIMUM RATE			D	
MINIMUM RATE			D	
<b>CIRCULATOR EXERCISING</b>	Circulator 1		D	
	Circulator 2		D	
	Circulator 3		D	
<b>FREEZE PROTECT CIRC'S</b>	Circulator 1		D	
	Circulator 2		D	
	Circulator 3		D	



## PIPING

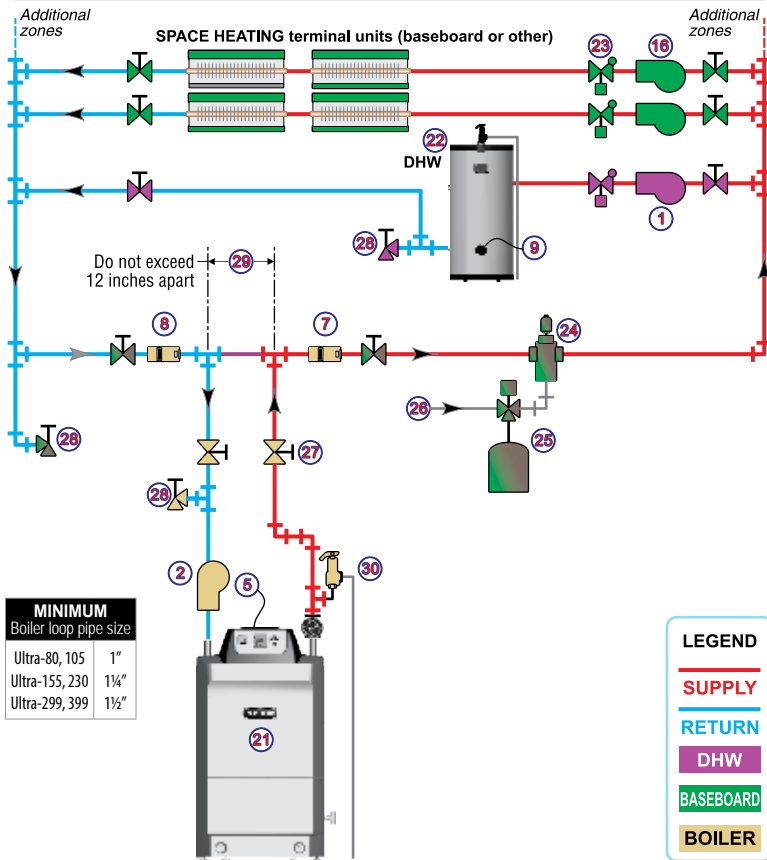

## LEGEND

- \* = Supplied by installer
- DHW circulator \*
  - BOILER circulator (shipped loose with boiler)
  - 120VAC power supply, 15-amp minimum rating
  - U-Control
  - Space heating zone thermostats \*
  - Supply temperature sensor — strap to supply line
  - Return temperature sensor — strap to return line
  - DHW tank aquastat or sensor\*
  - Outdoor temperature sensor
  - Low water cutoff (if used) \*
  - Circulator zone controller
  - Space heating zone circulators \*
  - Indirect water heater •
  - Flow/check valves \*
  - Air separator with automatic air vent \*
  - Diaphragm-type expansion tank \*
  - Fresh water supply — install per applicable codes \*
  - Isolation valves \*
  - Purge/drain valves \*
  - Secondary piping connection for boiler loop \*
  - Boiler relief valve (install per boiler manual)

## FIELD WIRING

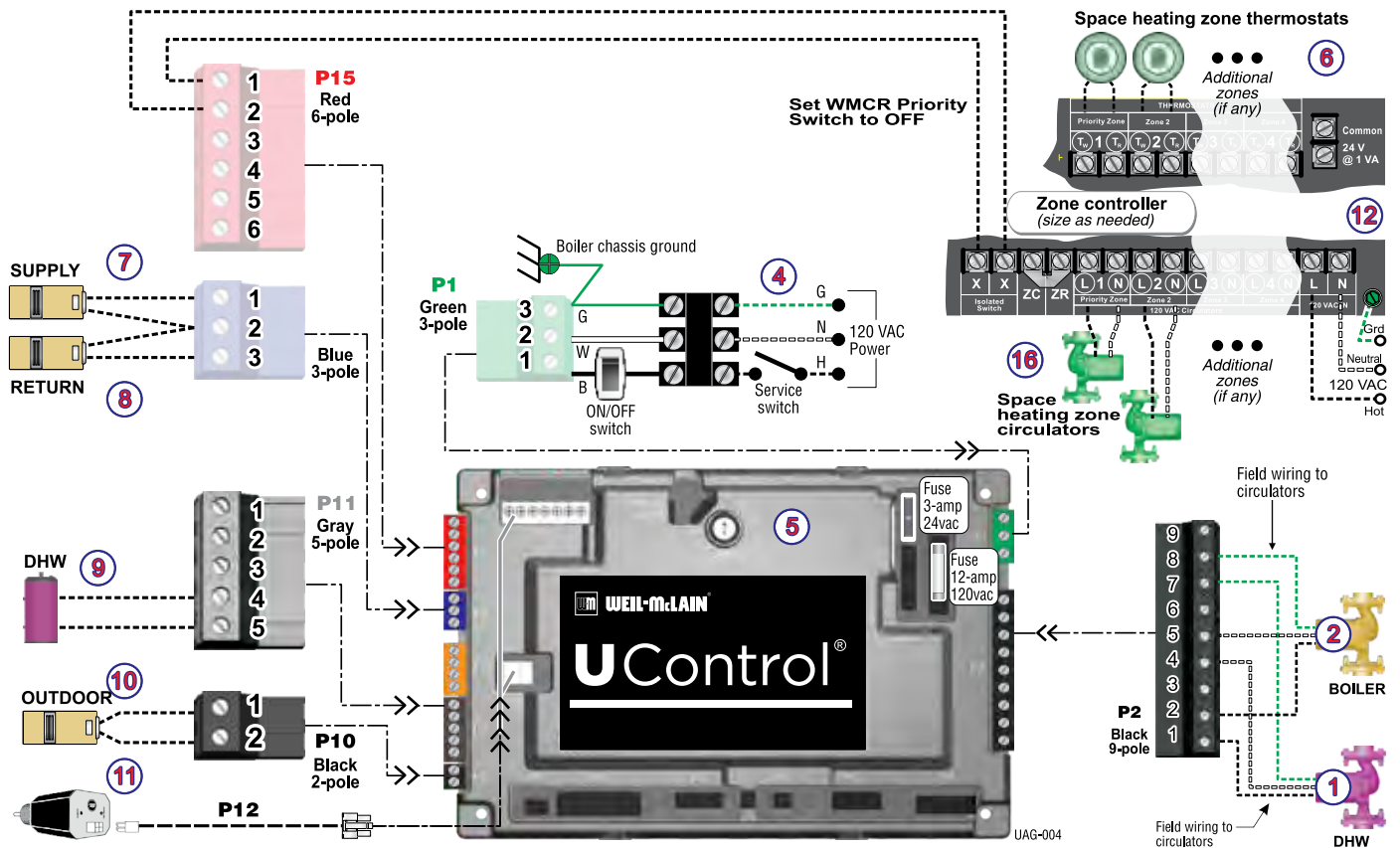



# Application 5

Multi-zone RADIANT | DHW (Direct-connected) | HEAT EXCHANGER (WMBP or WMPH) (<30% of total heat loss)

## Purpose

- Space heating with multiple radiant zones (zone valve zoning).
- Heat exchanger, brazed plate (WMBP) or pool heater (WMPH) in separate zone. Heating load must be less than 30% of total heat loss. Alternatively, see Application 7a, which does not limit load sizes.
- DHW piped directly to the boiler.
- DHW priority — space heating and heat exchanger heating are disabled during call for heat from water heater.

## U-Control setting notes

- See the table at right for required and optional settings.
- To see the navigation sequence to access the BOILER SETTINGS and SYSTEM SETTINGS menus, see page 7.
- Select DHW DIRECT for the DHW BOILER PRIORITY 1. This informs the control that the DHW tank is directly connected to the boiler.
- Select SYSTEM TYPE DHW for BOILER PRIORITY 3, the heat exchanger circuit. This prevents outdoor reset regulation of supply temperature during heat exchanger operation.

## Circulators and piping

- Piping must be primary/secondary as shown.

### DHW

- DHW circulator must be selected to handle the pressure drop through the Ultra boiler, water heater and piping — see boiler manual for recommended sizing. DHW circulator supplied by installer.
- For some large indirect water heaters, the required flow rate may require piping the water heater differently — see boiler manual and other applications in this guide.
- U-Control is set for DHW priority — space heating will be discontinued during a call for DHW.

### RADIANT

- Size circulators for required flow.
- Radiant circulators supplied by installer.

#### NOTICE

See **Application 7a**, page 22, for radiant heating using independent temperature control for the radiant zone.

### HEAT EXCHANGER

- Heat exchanger load must be less than 30% of total heat loss.
- Size circulator for required flow.
- Typical application shown using Weil-McLain brazed plate (WMBP) exchanger or pool heater (WMBP).
- Heat exchanger and circulator supplied by installer.

### BOILER

- See boiler manual for sizing.
- Circulator shipped loose with boiler.
- Boiler loop piping can be provided using optional Easy-Up Manifolds, available from Weil-McLain (see page 5).

## Wiring

- Connect field wiring as shown on next page.
- For circulators connected to the U-Control, the maximum circulator load is 2.2 amps each — if load is higher, provide a circulator relay or contactor for circulator power.
- Provide a relay to operate heat exchanger circulator and provide call for heat exchanger heating to U-Control input.

<b>U-CONTROL SETTINGS</b>			
(SEE NAVIGATION FLOW BELOW)		XXX	— VALUE MUST BE SET (OR VERIFIED) AS INDICATED
		D	— DEFAULT ACCEPTABLE; CHANGE ONLY IF DESIRED
<b>BOILER SETTINGS</b>			
BOILER MODEL		Verify model number is correct	
HIGH ALTITUDE		Set to YES if high altitude	
HIGH LIMIT		D	
WWSD TEMP		DEFAULT (70 °F) OR AS REQUIRED	
ADJUST OUTDOOR		DEFAULT (0 °F) OR AS REQUIRED	
ADD'L HEAT DEMAND TYPE		D	
ADD'L HEAT DEMAND TIME		D	
<b>SYSTEM SETTINGS</b>			
<b>BOILER PRIORITY 1 DHW</b>	SYSTEM TYPE	Select from list	DHW DIRECT
	TEMPERATURES	Max Supply	190 F
		Max OD Reset	D
		Min OD Reset	D
		Modulate On Diff	D
	TIMES	Max On Time	D
		Boost Interval	D
		Prepump Time: Postpump Time:	D D
	CIRCULATORS	Circulator 1 Circulator 2 Circulator 3	ON OFF OFF
	MAXIMUM RATE		D
MINIMUM RATE		D	
<b>BOILER PRIORITY 2 Radiant zones</b>	SYSTEM TYPE	Select from list	Note 1 (at left)
	TEMPERATURES	Max Supply	As required
		Min Supply	D
		Max OD Reset	D (70F) or as req'd
		Min OD Reset	D (0F) or as req'd
	TIMES	Max On Time	D
		Min On Time	D
		Boost Interval Prepump Time: Postpump Time:	D D D
	CIRCULATORS	Circulator 1 Circulator 2 Circulator 3	OFF ON ON
	MAXIMUM RATE		D
MINIMUM RATE		D	
<b>BOILER PRIORITY 3 Heat exchanger (&lt;30% of total heat loss)</b>	SYSTEM TYPE	Select from list	DHW SYSTEM
	TEMPERATURES	Max Supply	190 F
		Min Supply	D
		Max OD Reset	D
		Min OD Reset	D
	TIMES	Min On Time	D
		Boost Interval	D
		Prepump Time: Postpump Time:	D D
	CIRCULATORS	Circulator 1 Circulator 2 Circulator 3	OFF ON OFF
	MAXIMUM RATE		D
MINIMUM RATE		D	
CIRCULATOR EXERCISING	Circulator 1 Circulator 2 Circulator 3	D D D	
FREEZE PROTECT CIRCS	Circulator 1 Circulator 2 Circulator 3	D D D	





## PIPING

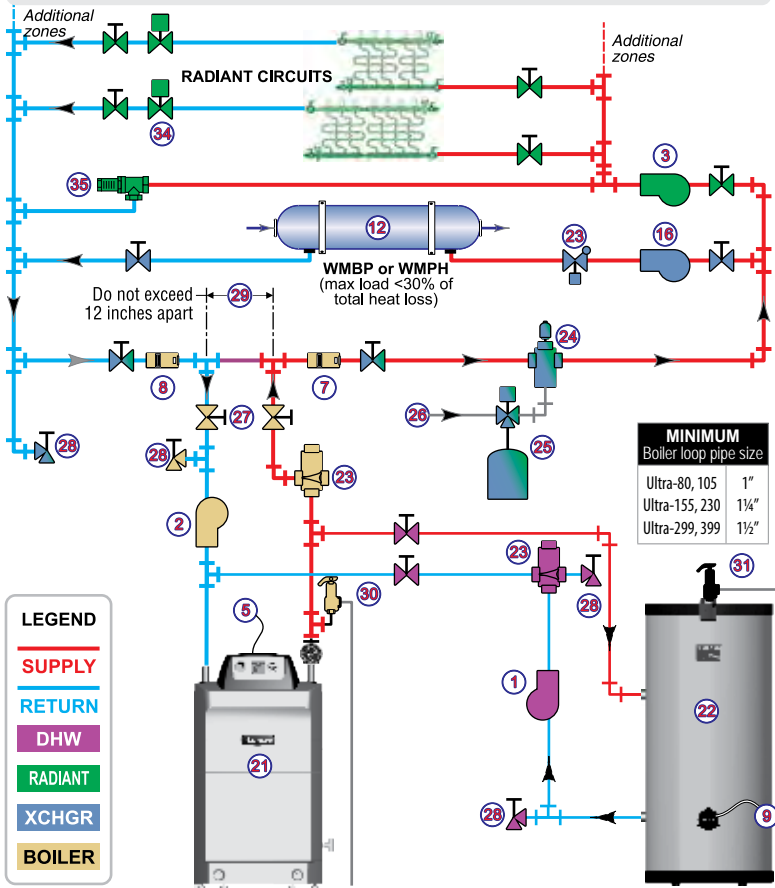

## LEGEND

\* = Supplied by installer

- 1 DHW circulator \*
- 2 BOILER circulator (shipped loose with boiler)
- 3 Radiant circulator \*
- 4 120VAC power supply, 15-amp minimum rating
- 5 U-Control
- 6 Radiant zone end switches \*
- 7 Supply temperature sensor — strap to supply line
- 8 Return temperature sensor — strap to return line
- 9 DHW tank aquastat or sensor \*
- 10 Outdoor temperature sensor (supplied with boiler; install if U-Control will be set for outdoor reset operation)
- 11 Low water cutoff (if used) \*
- 12 Heat exchanger
- 14 Heat exchanger aquastat or controller
- 15 2-pole relay for heat exchanger circulator operation \*
- 16 Heat exchanger circulator \*
- 21 Ultra boiler
- 22 Indirect water heater \*
- 23 Flow/check valves \*
- 24 Air separator with automatic air vent \*
- 25 Diaphragm-type expansion tank \*
- 26 Fresh water supply — install per applicable codes \*
- 27 Isolation valves \*
- 28 Purge/drain valves \*
- 29 Secondary piping connection for boiler loop \*
- 30 Boiler relief valve (install per boiler manual)
- 31 DHW Temperature and Pressure relief valve (install per boiler manual)
- 34 Zone valves
- 35 By-pass pressure regulator

## FIELD WIRING

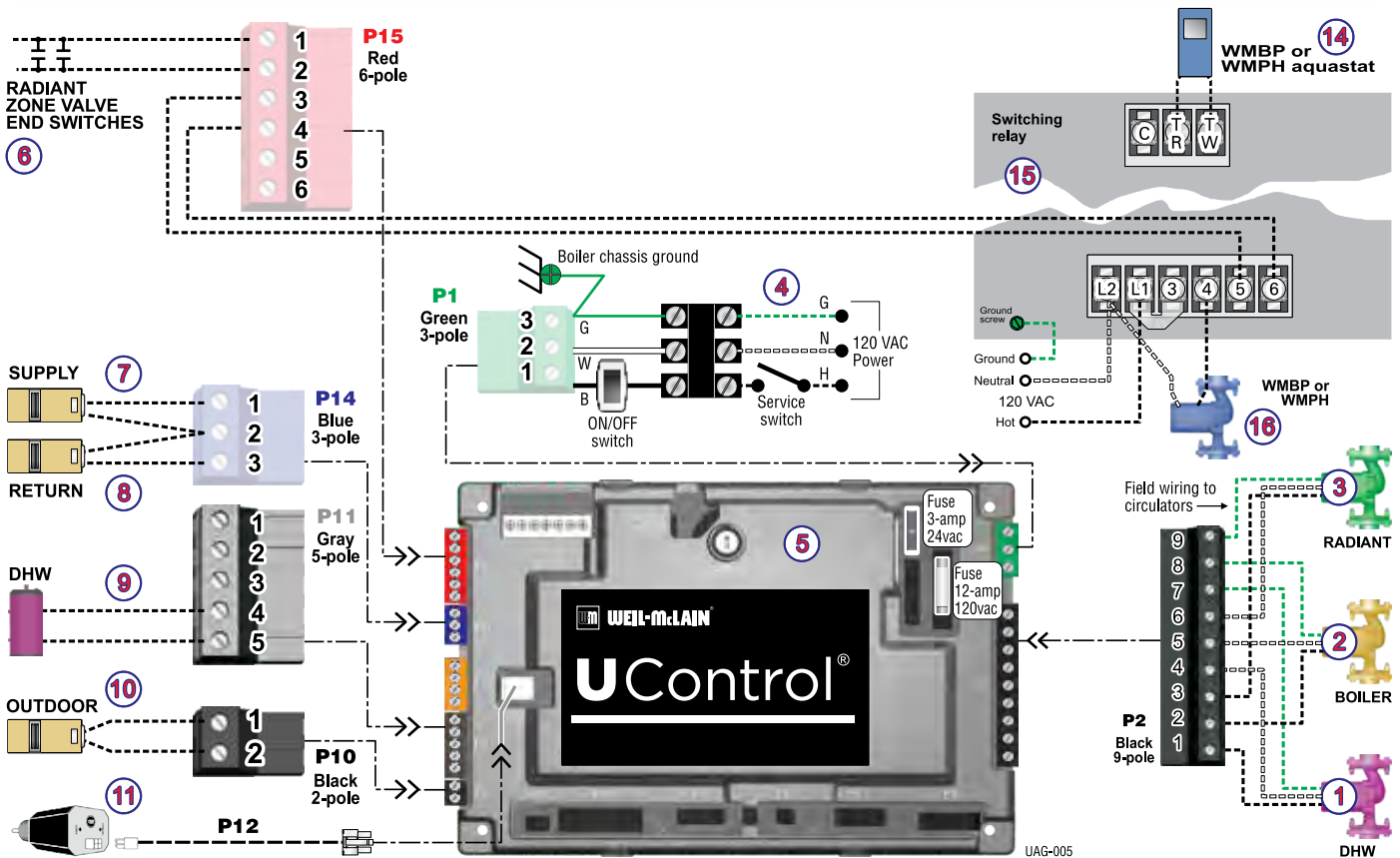



# Application 6

Multi-zone RADIANT | DHW (Direct-connected) | Small BASEBOARD zone (<30% of total heat loss)

## Purpose

- Radiant heating circuit with single or multiple zones (zone valves). Multiple-zone wiring not shown — must be provided using a zone controller or connecting zone valve end switches.
- Single-zone baseboard heating for a small space (heating load less than 30% of total heat loss — alternatively, see Application 7a, which does not limit load sizes).
- DHW piped directly to the boiler.
- DHW priority — space heating and heater exchanger heating are disabled during call for heat from water heater.

## U-Control setting notes

- See the table at right for required and optional settings.
- To see the navigation sequence to access the BOILER SETTINGS and SYSTEM SETTINGS menus, see page 7.
- Select DHW DIRECT for the DHW BOILER PRIORITY 1. This informs the control that the DHW tank is directly connected to the boiler.

## Circulators and piping

- Piping must be primary/secondary as shown.

### DHW

- DHW circulator must be selected to handle the pressure drop through the Ultra boiler, water heater and piping — see boiler manual for recommended sizing. DHW circulator supplied by installer.
- For some large indirect water heaters, the required flow rate may require piping the water heater differently — see boiler manual and other applications in this guide.
- U-Control is set for DHW priority — space heating will be discontinued during a call for DHW.

### RADIANT

- Size circulators for required flow.
- Radiant circulators supplied by installer.

#### NOTICE

See **Application 7a**, page 22, for radiant heating using independent temperature control for the radiant zone.

### BASEBOARD

- Baseboard load must be less than 30% of total heat loss.
- Size circulator for required flow.
- Baseboard circulator supplied by installer.

### BOILER

- See boiler manual for sizing.
- Circulator shipped loose with boiler.
- Boiler loop piping can be provided using optional Easy-Up Manifolds, available from Weil-McLain (see page 5).

## Wiring

- Connect field wiring as shown on next page.
- For circulators connected to the U-Control, the maximum circulator load is 2.2 amps each — if load is higher, provide a circulator relay or contactor for circulator power.
- Provide a relay to operate baseboard circulator and provide call for baseboard heating to U-Control input.
- If using multiple zones, provide components and wiring needed to operate zone components and provide call for heat to the U-control input.

<b>U-CONTROL SETTINGS</b>			
(SEE NAVIGATION FLOW BELOW)		XXX	— VALUE MUST BE SET (OR VERIFIED) AS INDICATED
		D	— DEFAULT ACCEPTABLE; CHANGE ONLY IF DESIRED
<b>BOILER SETTINGS</b>			
BOILER MODEL		Verify model number is correct	
HIGH ALTITUDE		Set to YES if high altitude	
HIGH LIMIT		D	
WWSD TEMP		DEFAULT (70 °F) OR AS REQUIRED	
ADJUST OUTDOOR		DEFAULT (0 °F) OR AS REQUIRED	
ADD'L HEAT DEMAND TYPE		D	
ADD'L HEAT DEMAND TIME		D	
<b>SYSTEM SETTINGS</b>			
<b>BOILER PRIORITY 1 DHW</b>	SYSTEM TYPE	Select from list	DHW DIRECT
	TEMPERATURES	Max Supply	190 F
		Max OD Reset	D
		Min OD Reset	D
		Modulate On Diff	D
	TIMES	Max On Time	D
		Boost Interval	D
		Prepump Time: Postpump Time:	D D
	CIRCULATORS	Circulator 1	ON
		Circulator 2	OFF
		Circulator 3	OFF
	MAXIMUM RATE		D
MINIMUM RATE		D	
<b>BOILER PRIORITY 2 Radiant</b>	SYSTEM TYPE	Select from list	Note 1 (at left)
	TEMPERATURES	Max Supply	As required
		Min Supply	D
		Max OD Reset	D (70F) or as req'd
		Min OD Reset	D (0F) or as req'd
	TIMES	Max On Time	D
		Min On Time	D
		Boost Interval	D
	CIRCULATORS	Circulator 1	OFF
		Circulator 2	ON
		Circulator 3	ON
	MAXIMUM RATE		D
MINIMUM RATE		D	
<b>BOILER PRIORITY 3 Baseboard (Finned tube or cast iron) (&lt;30% of total heat loss)</b>	SYSTEM TYPE	Select from list	FTB or CIB
	TEMPERATURES	Max Supply	180 F
		Min Supply	D
		Max OD Reset	D (70F) or as req'd
		Min OD Reset	D (0F) or as req'd
	TIMES	Min On Time	D
		Boost Interval	D
		Prepump Time: Postpump Time:	D D
	CIRCULATORS	Circulator 1	OFF
		Circulator 2	ON
		Circulator 3	OFF
	MAXIMUM RATE		D
MINIMUM RATE		D	
CIRCULATOR EXERCISING	Circulator 1 Circulator 2 Circulator 3		D D D
FREEZE PROTECT CIRCS	Circulator 1 Circulator 2 Circulator 3		D D D



## PIPING

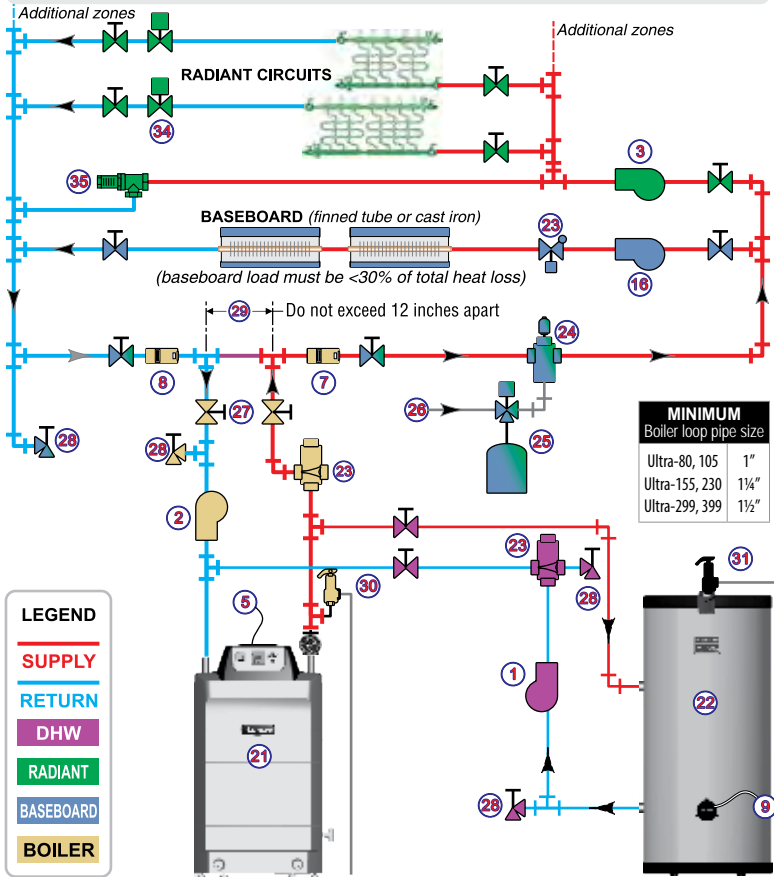

## LEGEND

\* = Supplied by installer

- DHW circulator \*
- BOILER circulator (shipped loose with boiler)
- Radiant circulator \*
- 120VAC power supply, 15-amp minimum rating
- U-Control
- Radiant zone end switches\*
- Supply temperature sensor — strap to supply line
- Return temperature sensor — strap to return line
- DHW tank aquastat or sensor\*
- Outdoor temperature sensor (supplied with boiler; install if U-Control will be set for outdoor reset operation)
- Low water cutoff (if used) \*
- Baseboard thermostat \*
- Two-pole relay to operate baseboard circulator \*
- Baseboard circulator \*
- Ultra boiler
- Indirect water heater \*
- Flow/check valves \*
- Air separator with automatic air vent \*
- Diaphragm-type expansion tank \*
- Fresh water supply — install per applicable codes \*
- Isolation valves \*
- Purge/drain valves \*
- Secondary piping connection for boiler loop \*
- Boiler relief valve (install per boiler manual)
- DHW Temperature and Pressure relief valve (install per boiler manual)
- Zone valves \*
- Bypass pressure regulator \*

## FIELD WIRING

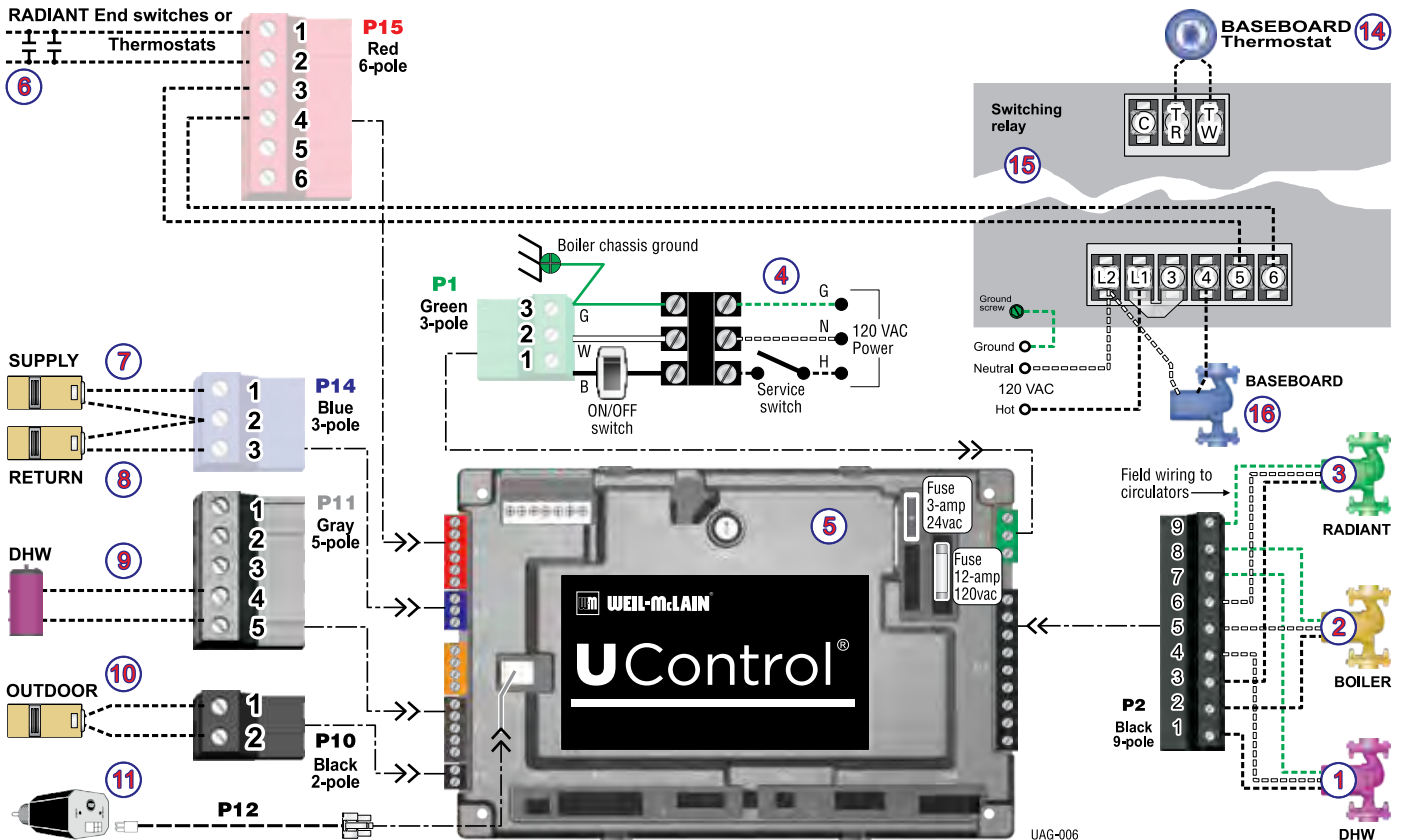



# Application 7

Multiple **HI-TEMP HEATING** zones | DHW (Direct-connected) | **Small RADIANT zone** (<30 of total heat loss)

## Purpose

- Radiant heating and hi-temp (180°F typical) space heating with single or multiple zones (circulator zoning). Hi-temp space heating terminal units can be baseboard, fan coil, radiators or heat exchangers. Fan coils must be equipped with minimum temp aquastats, because their circulators can operate during radiant circuit operation (supply water temperature could be too low for fan coils).
- DHW piped directly to the boiler.
- DHW priority — space heating and heater exchanger heating are disabled during call for heat from water heater.

## U-Control setting notes

- See the table at right for required and optional settings.
- To see the navigation sequence to access the BOILER SETTINGS and SYSTEM SETTINGS menus, see page 7.
- Select DHW DIRECT for the DHW BOILER PRIORITY 1. This informs the control that the DHW tank is directly connected to the boiler.

## Circulators and piping

- Piping must be primary/secondary as shown.

### DHW

- DHW circulator must be selected to handle the pressure drop through the Ultra boiler, water heater and piping — see boiler manual for recommended sizing. DHW circulator supplied by installer.
- For some large indirect water heaters, the required flow rate may require piping the water heater differently — see boiler manual and other applications in this guide.
- U-Control is set for DHW priority — space heating will be discontinued during a call for DHW.

### HI-TEMP SPACE HEATING

- Multiple zones with circulators controlled by a zone controller.
- Size circulators for required flow.
- Space heating zone circulators supplied by installer.

### RADIANT

- Radiant load must be less than 30% of total heat loss.

**NOTICE**

See **Application 7a**, page 22, for radiant heating using independent temperature control for the radiant zone, with no limit to the radiant load.

- Size circulator for required flow.
- Radiant circulator supplied by installer.

### BOILER

- See boiler manual for sizing.
- Circulator shipped loose with boiler.
- Boiler loop piping can be provided using optional Easy-Up Manifolds, available from Weil-McLain (see page 5).

## Wiring

- Connect field wiring as shown on next page.
- For circulators connected to the U-Control, the maximum circulator load is 2.2 amps each — if load is higher, provide a circulator relay or contactor for circulator power.
- Provide a circulator zone controller to control all hi-temp zone circulators, sized for the number of zones required.

<b>U-CONTROL SETTINGS</b>			
(SEE NAVIGATION FLOW BELOW)		<b>XXX</b>	— VALUE MUST BE SET (OR VERIFIED) AS INDICATED
		<b>D</b>	— DEFAULT ACCEPTABLE; CHANGE ONLY IF DESIRED
<b>BOILER SETTINGS</b>			
BOILER MODEL	Verify model number is correct		
HIGH ALTITUDE	Set to YES if high altitude		
HIGH LIMIT	D		
WWSD TEMP	DEFAULT (70 °F) OR AS REQUIRED		
ADJUST OUTDOOR	DEFAULT (0 °F) OR AS REQUIRED		
ADD'L HEAT DEMAND TYPE	D		
ADD'L HEAT DEMAND TIME	D		
<b>SYSTEM SETTINGS</b>			
<b>BOILER PRIORITY 1 DHW</b>	SYSTEM TYPE	Select from list	DHW Direct
	TEMPERATURES	Max Supply	190 F
		Max OD Reset	D
		Min OD Reset	D
		Modulate On Diff	D
	TIMES	Modulate Off Diff	D
		Max On Time	D
		Boost Interval	D
	CIRCULATORS	Prepump Time:	D
		Postpump Time:	D
Circulator 1		ON	
MAXIMUM RATE	Circulator 2	OFF	
	Circulator 3	OFF	
	MINIMUM RATE		D
<b>BOILER PRIORITY 2 Hi-temp space htg.</b>	SYSTEM TYPE	Select from list	Note 1 (at left)
	TEMPERATURES	Max Supply	As required
		Min Supply	D
		Max OD Reset	D (70F) or as req'd
		Min OD Reset	D (0F) or as req'd
	TIMES	Modulate On Diff	D
		Modulate Off Diff	D
		Min On Time	D
	CIRCULATORS	Boost Interval	D
		Prepump Time:	D
Postpump Time:		D	
MAXIMUM RATE	Circulator 1	OFF	
	Circulator 2	ON	
	Circulator 3	OFF	
MINIMUM RATE		D	
		D	
		D	
<b>BOILER PRIORITY 3 Radiant (&lt;30 of total heat loss)</b>	SYSTEM TYPE	Select from list	Note 2 (at left)
	TEMPERATURES	Max Supply	As required
		Min Supply	D
		Max OD Reset	D (70F) or as req'd
		Min OD Reset	D (0F) or as req'd
	TIMES	Modulate On Diff	D
		Modulate Off Diff	D
		Max On Time	D
	CIRCULATORS	Min On Time	D
		Boost Interval	D
Prepump Time:		D	
MAXIMUM RATE	Postpump Time:	D	
	Circulator 1	OFF	
	Circulator 2	ON	
MINIMUM RATE	Circulator 3	ON	
		D	
		D	
CIRCULATOR EXERCISING	Circulator 1	D	
	Circulator 2	D	
	Circulator 3	D	
FREEZE PROTECT CIRC'S	Circulator 1	D	
	Circulator 2	D	
	Circulator 3	D	



## PIPING

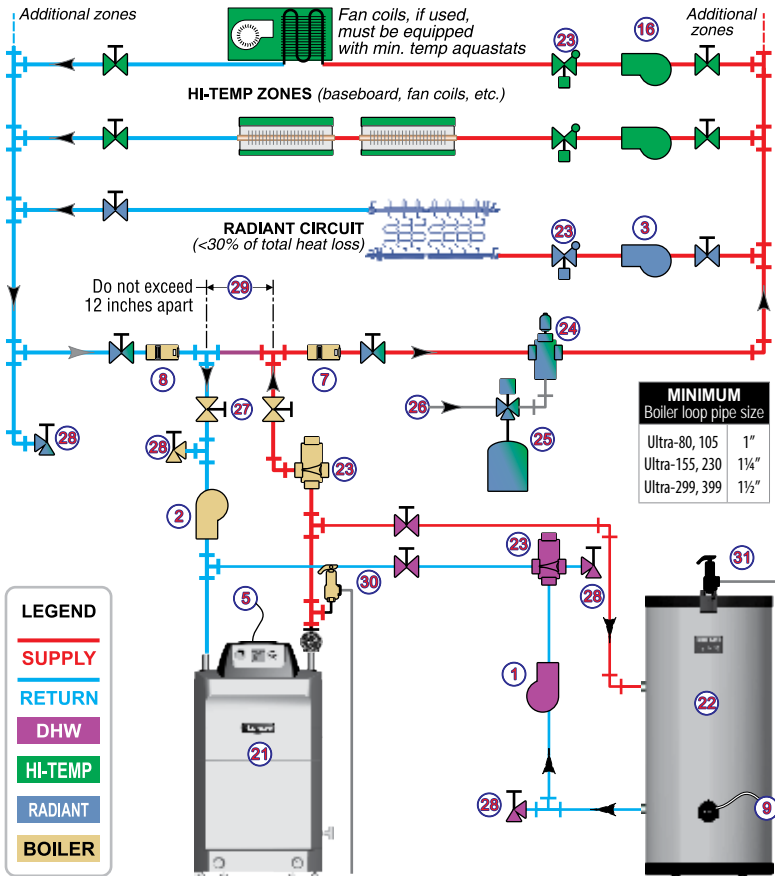

## LEGEND

\* = Supplied by installer

- 1 DHW circulator \*
- 2 BOILER circulator (shipped loose with boiler)
- 3 Radiant zone circulator \*
- 4 120VAC power supply, 15-amp minimum rating
- 5 U-Control
- 6 Hi-temp zone thermostat \*
- 7 Supply temperature sensor — strap to supply line
- 8 Return temperature sensor — strap to return line
- 9 DHW tank aquastat or sensor \*
- 10 Outdoor temperature sensor (supplied with boiler; install if U-Control will be set for outdoor reset operation)
- 11 Low water cutoff (if used) \*
- 14 Radiant zone thermostat \*
- 15 Circulator zone controller (select for number of zones required) \*
- 16 Hi-temp zone circulator \*
- 21 Ultra boiler
- 22 Indirect water heater \*
- 23 Flow/check valves \*
- 24 Air separator with automatic air vent \*
- 25 Diaphragm-type expansion tank \*
- 26 Fresh water supply — install per applicable codes \*
- 27 Isolation valves \*
- 28 Purge/drain valves \*
- 29 Secondary piping connection for boiler loop \*
- 30 Boiler relief valve (install per boiler manual)
- 31 DHW Temperature and Pressure relief valve (install per boiler manual)

## FIELD WIRING

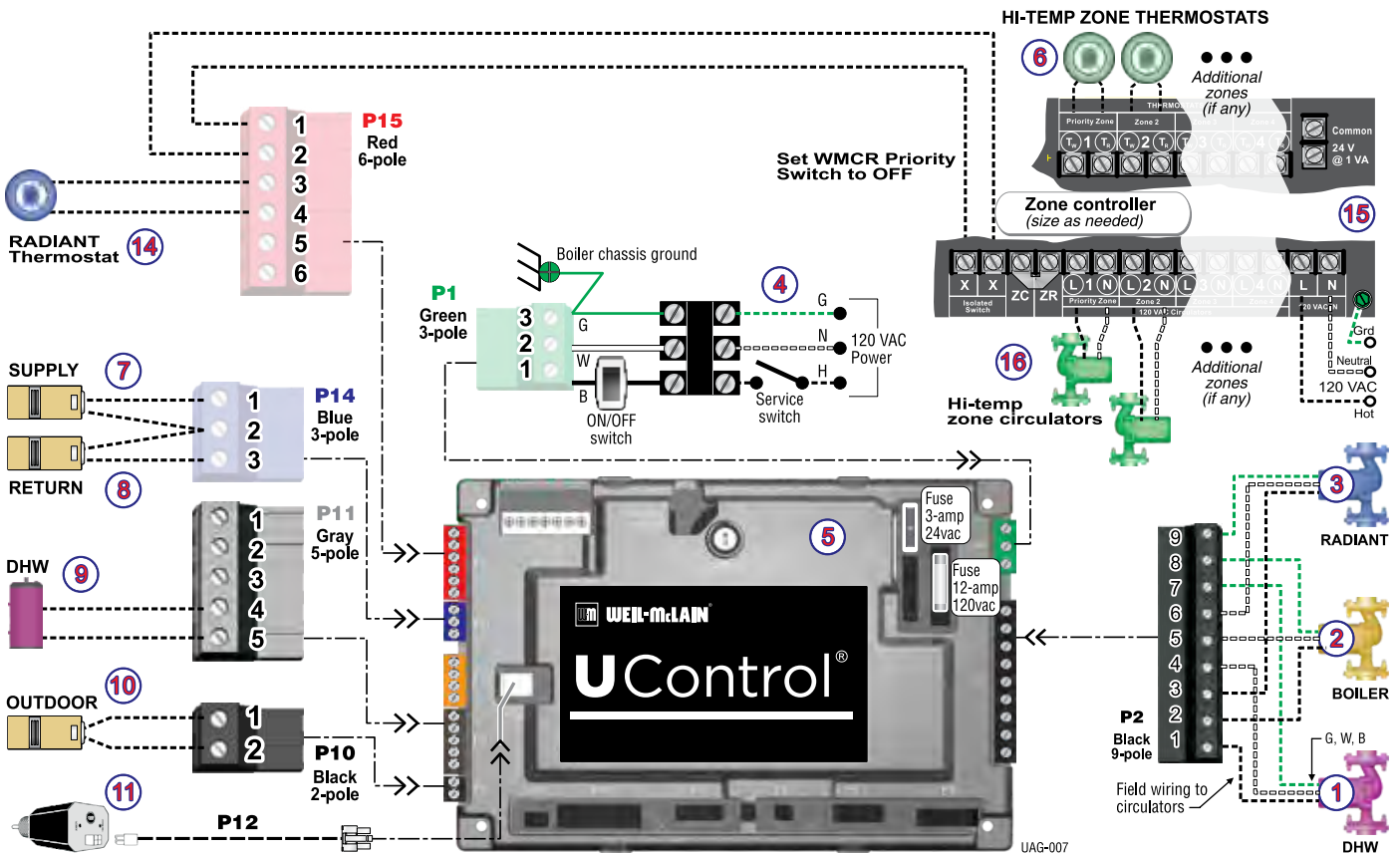



# Application 7a

**Multi-zone HI-TEMP HEATING plus RADIANT (with mixing valve) | DHW (Direct-connected)**  
 (No limits on the relative heating loads of radiant or hi-temp space heating circuits)

## Purpose

- Radiant heating and hi-temp (180°F typical) space heating with single or multiple zones (circulator zoning). Hi-temp space heating terminal units can be baseboard, fan coil, radiators or heat exchangers.
- Supply water temperature is selected for the hi-temp zones. The mixing valve regulates supply temperature to the lower-temperature radiant zones.
- All circulators (hi temp and radiant) are operated by a circulator zone controller.
- DHW piped directly to the boiler.
- DHW priority — space heating is disabled during call for heat from water heater.

## U-Control setting notes

- See the table at right for required and optional settings.
- To see the navigation sequence to access the BOILER SETTINGS and SYSTEM SETTINGS menus, see page 7.
- Select DHW DIRECT for the DHW BOILER PRIORITY 1. This informs the control that the DHW tank is directly connected to the boiler.

## Circulators and piping

- Piping must be primary/secondary as shown.

### DHW

- DHW circulator must be selected to handle the pressure drop through the Ultra boiler, water heater and piping — see boiler manual for recommended sizing. DHW circulator supplied by installer.
- For some large indirect water heaters, the required flow rate may require piping the water heater differently — see boiler manual and other applications in this guide.
- U-Control is set for DHW priority — space heating will be discontinued during a call for DHW.

### HI-TEMP SPACE HEATING

- Multiple zones with circulators controlled by a zone controller.
- Size circulators for required flow.
- All space heating circulators (hi-temp and radiant) supplied by installer.

### BOILER

- See boiler manual for sizing.
- Circulator shipped loose with boiler.
- Boiler loop piping can be provided using optional Easy-Up Manifolds, available from Weil-McLain (see page 5).

## Wiring

- Connect field wiring as shown on next page.
- For circulators connected to the U-Control, the maximum circulator load is 2.2 amps each — if load is higher, provide a circulator relay or contactor for circulator power.
- Provide a circulator zone controller to control all space heating zone circulators (hi-temp and radiant), sized for the number of zones required.

<b>U-CONTROL SETTINGS</b>		XXX	— VALUE MUST BE SET (OR VERIFIED) AS INDICATED
(SEE NAVIGATION FLOW BELOW)		D	— DEFAULT ACCEPTABLE; CHANGE ONLY IF DESIRED
<b>BOILER SETTINGS</b>			
BOILER MODEL		Verify model number is correct	
HIGH ALTITUDE		Set to YES if high altitude	
HIGH LIMIT		D	
WWSD TEMP		DEFAULT (70 °F) OR AS REQUIRED	
ADJUST OUTDOOR		DEFAULT (0 °F) OR AS REQUIRED	
ADD'L HEAT DEMAND TYPE		D	
ADD'L HEAT DEMAND TIME		D	
<b>SYSTEM SETTINGS</b>			
<b>BOILER PRIORITY 1 DHW</b>	SYSTEM TYPE	Select from list	DHW Direct
	TEMPERATURES	Max Supply	190 F
		Max OD Reset	D
		Min OD Reset	D
		Modulate On Diff	D
	TIMES	Modulate Off Diff	D
		Max On Time	D
		Boost Interval	D
	CIRCULATORS	Prepump Time:	D
		Postpump Time:	D
Circulator 1		ON	
MAXIMUM RATE	Circulator 2	OFF	
	Circulator 3	OFF	
	MINIMUM RATE		D
<b>BOILER PRIORITY 2 Space heating — select type most typical of hi-temp terminal units and highest supply temp required</b>	SYSTEM TYPE	Select from list	Select
	TEMPERATURES	Max Supply	As required
		Min Supply	D
		Max OD Reset	D (70F) or as req'd
		Min OD Reset	D (0F) or as req'd
	TIMES	Modulate On Diff	D
		Modulate Off Diff	D
		Min On Time	D
	CIRCULATORS	Boost Interval	D
		Prepump Time:	D
Postpump Time:		D	
MAXIMUM RATE	Circulator 1	OFF	
	Circulator 2	ON	
	Circulator 3	OFF	
MINIMUM RATE		D	
<b>BOILER PRIORITY 3 Not used</b>	SYSTEM TYPE	Select from list	D
	TEMPERATURES	Max Supply	D
		Min Supply	D
		Max OD Reset	D
		Min OD Reset	D
	TIMES	Modulate On Diff	D
		Modulate Off Diff	D
		Min On Time	D
	CIRCULATORS	Boost Interval	D
		Prepump Time:	D
Postpump Time:		D	
MAXIMUM RATE	Circulator 1	D	
	Circulator 2	D	
	Circulator 3	D	
MINIMUM RATE		D	
<b>CIRCULATOR EXERCISING</b>	Circulator 1	D	
	Circulator 2	D	
	Circulator 3	D	
<b>FREEZE PROTECT CIRC</b>	Circulator 1	D	
	Circulator 2	D	
	Circulator 3	D	



## PIPING

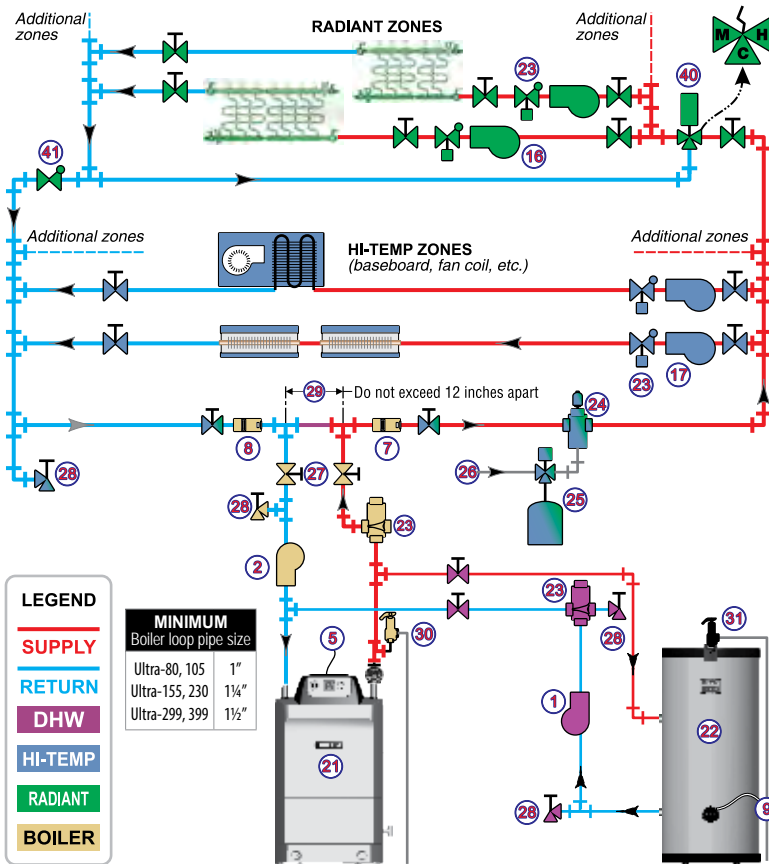

## LEGEND

\* = Supplied by installer

- 1 DHW circulator \*
- 2 BOILER circulator (shipped loose with boiler)
- 4 120VAC power supply, 15-amp minimum rating
- 5 U-Control
- 6 Hi-temp zone thermostats \*
- 7 Supply temperature sensor — strap to supply line
- 8 Return temperature sensor — strap to return line
- 9 DHW tank aquastat or sensor \*
- 10 Outdoor temperature sensor (supplied with boiler; install if U-Control will be set for outdoor reset operation)
- 11 Low water cutoff (if used) \*
- 15 Circulator zone controller \*
- 16 Radiant zone circulators \*
- 17 Hi-temp zone circulators \*
- 18 Radiant zone thermostat \*
- 21 Ultra boiler
- 22 Indirect water heater \*
- 23 Flow/check valves \*
- 24 Air separator with automatic air vent \*
- 25 Diaphragm-type expansion tank \*
- 26 Fresh water supply — install per applicable codes \*
- 27 Isolation valves \*
- 28 Purge/drain valves \*
- 29 Secondary piping connection for boiler loop \*
- 30 Boiler relief valve (install per boiler manual)
- 31 DHW Temperature and Pressure relief valve (install per boiler manual)
- 40 Mixing valve — controls supply temperature to radiant zones \*
- 41 Check valve \*

## FIELD WIRING

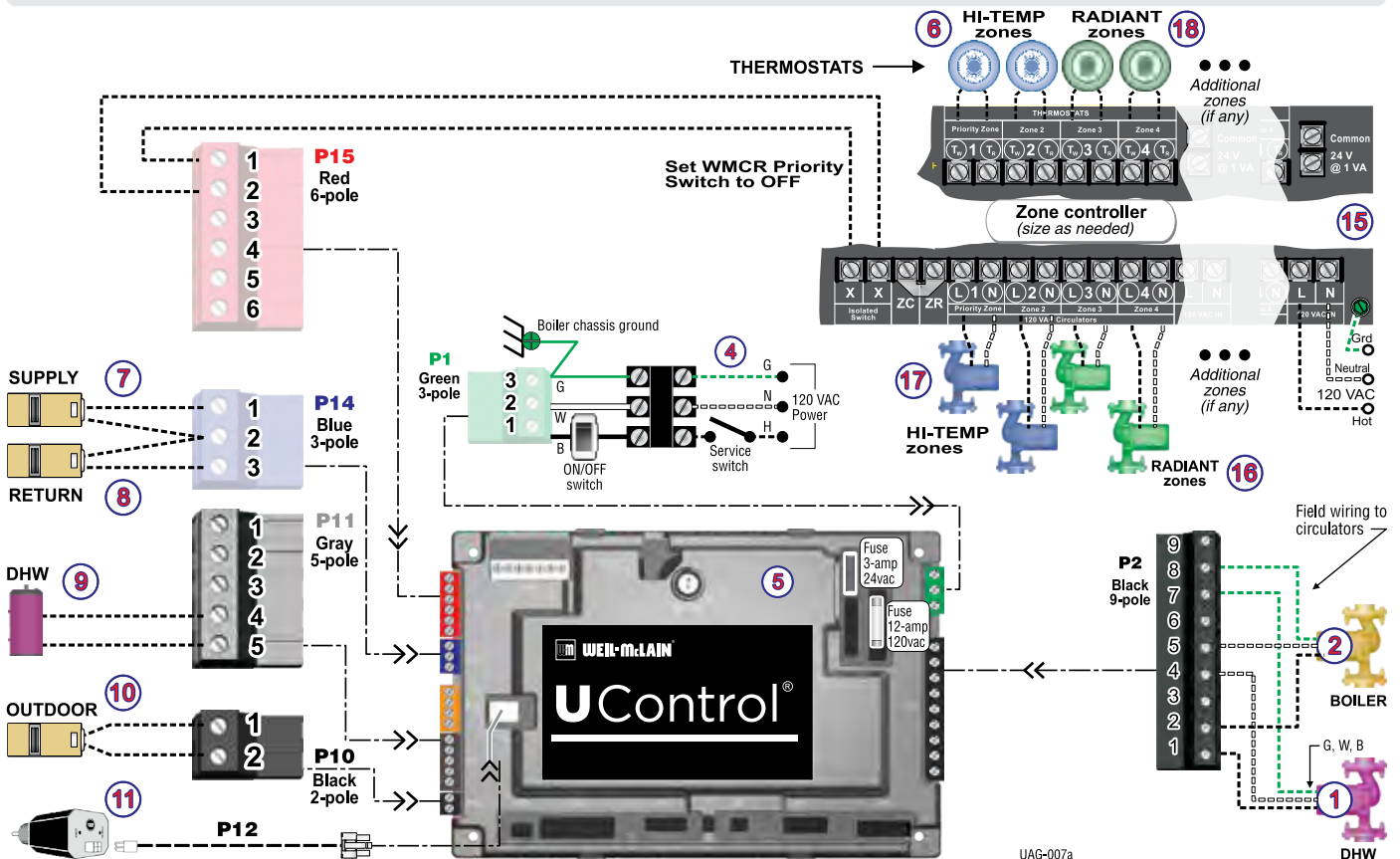



# Application 8

**Multi-zone BASEBOARD (Zone valves + WMZV controller) | DHW (Direct-connected)**

## Purpose

- Space heating with multiple baseboard zones.
- Zoning with zone valves.
- DHW piped directly to the boiler.
- DHW priority — space heating and heater exchanger heating are disabled during call for heat from water heater.

## U-Control setting notes

- See the table at right for required and optional settings.
- To see the navigation sequence to access the BOILER SETTINGS and SYSTEM SETTINGS menus, see page 7.
- Select DHW DIRECT for the DHW BOILER PRIORITY 1. This informs the control that the DHW tank is directly connected to the boiler.

## Circulators and piping

- Piping must be primary/secondary as shown.

### DHW

- DHW circulator must be selected to handle the pressure drop through the Ultra boiler, water heater and piping — see boiler manual for recommended sizing. DHW circulator supplied by installer.
- For some large indirect water heaters, the required flow rate may require piping the water heater differently — see boiler manual and other applications in this guide.
- U-Control is set for DHW priority — space heating will be discontinued during a call for DHW.

### BASEBOARD

- Size for required flow.
- System circulator supplied by installer.
- Multiple zones (with zone valves and bypass pressure regulator by installer).

### BOILER

- See boiler manual for sizing.
- Circulator shipped loose with boiler.
- Boiler loop piping can be provided using optional Easy-Up Manifolds, available from Weil-McLain (see page 5).

## Wiring

- Connect field wiring as shown on next page.
- This application applies only to multiple-zone space heating, using a zone controller.
- For circulators connected to the U-Control, the maximum circulator load is 2.2 amps each — if load is higher, provide a circulator relay or contactor for circulator power.
- Provide a zone valve controller.

<b>U-CONTROL SETTINGS</b>			
(SEE NAVIGATION FLOW BELOW)		<b>XXX</b>	— VALUE MUST BE SET (OR VERIFIED) AS INDICATED
		<b>D</b>	— DEFAULT ACCEPTABLE; CHANGE ONLY IF DESIRED
<b>BOILER SETTINGS</b>			
BOILER MODEL		Verify model number is correct	
HIGH ALTITUDE		Set to YES if high altitude	
HIGH LIMIT		D	
WWSD TEMP		DEFAULT (70 °F) OR AS REQUIRED	
ADJUST OUTDOOR		DEFAULT (0 °F) OR AS REQUIRED	
ADD'L HEAT DEMAND TYPE		D	
ADD'L HEAT DEMAND TIME		D	
<b>SYSTEM SETTINGS</b>			
<b>BOILER PRIORITY 1 DHW</b>	SYSTEM TYPE	Select from list	DHW Direct
	TEMPERATURES	Max Supply	190 F
		Max OD Reset	D
		Min OD Reset	D
		Modulate On Diff	D
	TIMES	Modulate Off Diff	D
		Max On Time	D
		Boost Interval Prepump Time: Postpump Time:	D D D
	CIRCULATORS	Circulator 1	ON
		Circulator 2	OFF
Circulator 3		OFF	
MAXIMUM RATE		D	
MINIMUM RATE		D	
<b>BOILER PRIORITY 2 Baseboard (Finned tube or cast iron)</b>	SYSTEM TYPE	Select from list	FTB or CIB
	TEMPERATURES	Max Supply	180 F
		Min Supply	D
		Max OD Reset	D (70F) or as req'd
		Min OD Reset	D (0F) or as req'd
	TIMES	Modulate On Diff	D
		Modulate Off Diff	D
		Max On Time Min On Time Boost Interval Prepump Time: Postpump Time:	D D D D D
	CIRCULATORS	Circulator 1	OFF
		Circulator 2	ON
Circulator 3		ON	
MAXIMUM RATE		D	
MINIMUM RATE		D	
<b>BOILER PRIORITY 3 Not used</b>	SYSTEM TYPE	Select from list	D
	TEMPERATURES	Max Supply	D
		Min Supply	D
		Max OD Reset	D
		Min OD Reset	D
	TIMES	Modulate On Diff	D
		Modulate Off Diff	D
		Min On Time Boost Interval Prepump Time: Postpump Time:	D D D D
	CIRCULATORS	Circulator 1	D
		Circulator 2	D
Circulator 3		D	
MAXIMUM RATE		D	
MINIMUM RATE		D	
<b>CIRCULATOR EXERCISING</b>	Circulator 1	D	
	Circulator 2	D	
	Circulator 3	D	
<b>FREEZE PROTECT CIRC'S</b>	Circulator 1	D	
	Circulator 2	D	
	Circulator 3	D	





## PIPING

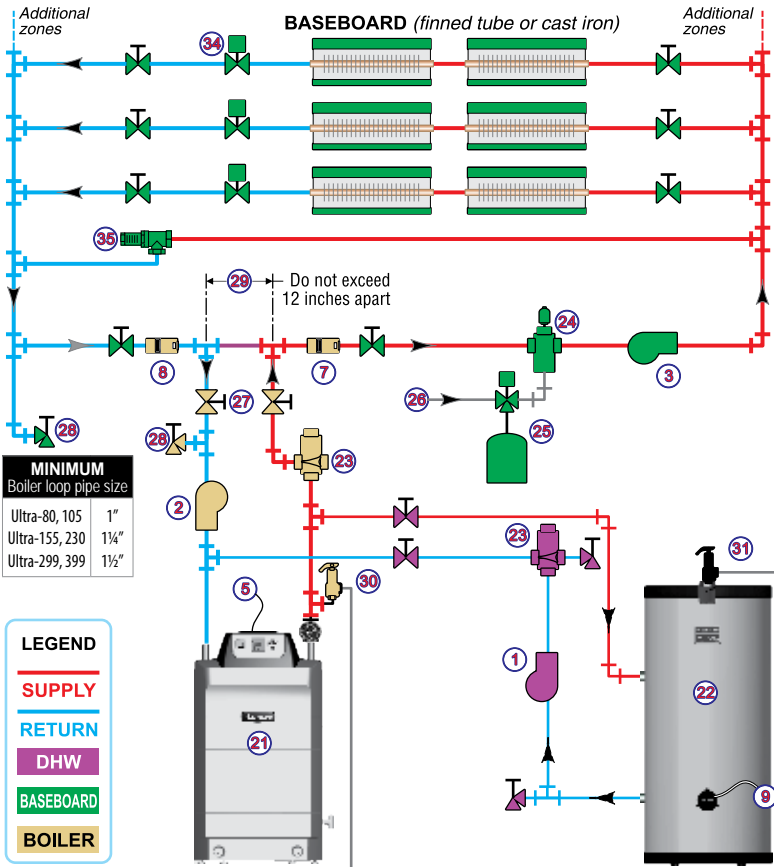

## LEGEND

\* = Supplied by installer

- DHW circulator \*
- BOILER circulator (shipped loose with boiler)
- SYSTEM circulator \*
- 120VAC power supply, 15-amp minimum rating
- U-Control
- Baseboard zone thermostats \*
- Supply temperature sensor — strap to supply line
- Return temperature sensor — strap to return line
- DHW tank aquastat or sensor\*
- Outdoor temperature sensor (supplied with boiler; install if U-Control will be set for outdoor reset operation)
- Low water cutoff (if used) \*
- Ultra boiler
- Indirect water heater \*
- Flow/check valves \*
- Air separator with automatic air vent \*
- Diaphragm-type expansion tank \*
- Fresh water supply — install per applicable codes \*
- Isolation valves \*
- Purge/drain valves \*
- Secondary piping connection for boiler loop \*
- Boiler relief valve (install per boiler manual)
- DHW Temperature and Pressure relief valve (install per boiler manual)
- Zone valves \*
- Bypass pressure regulator \*
- Zone valve controller \*

## FIELD WIRING

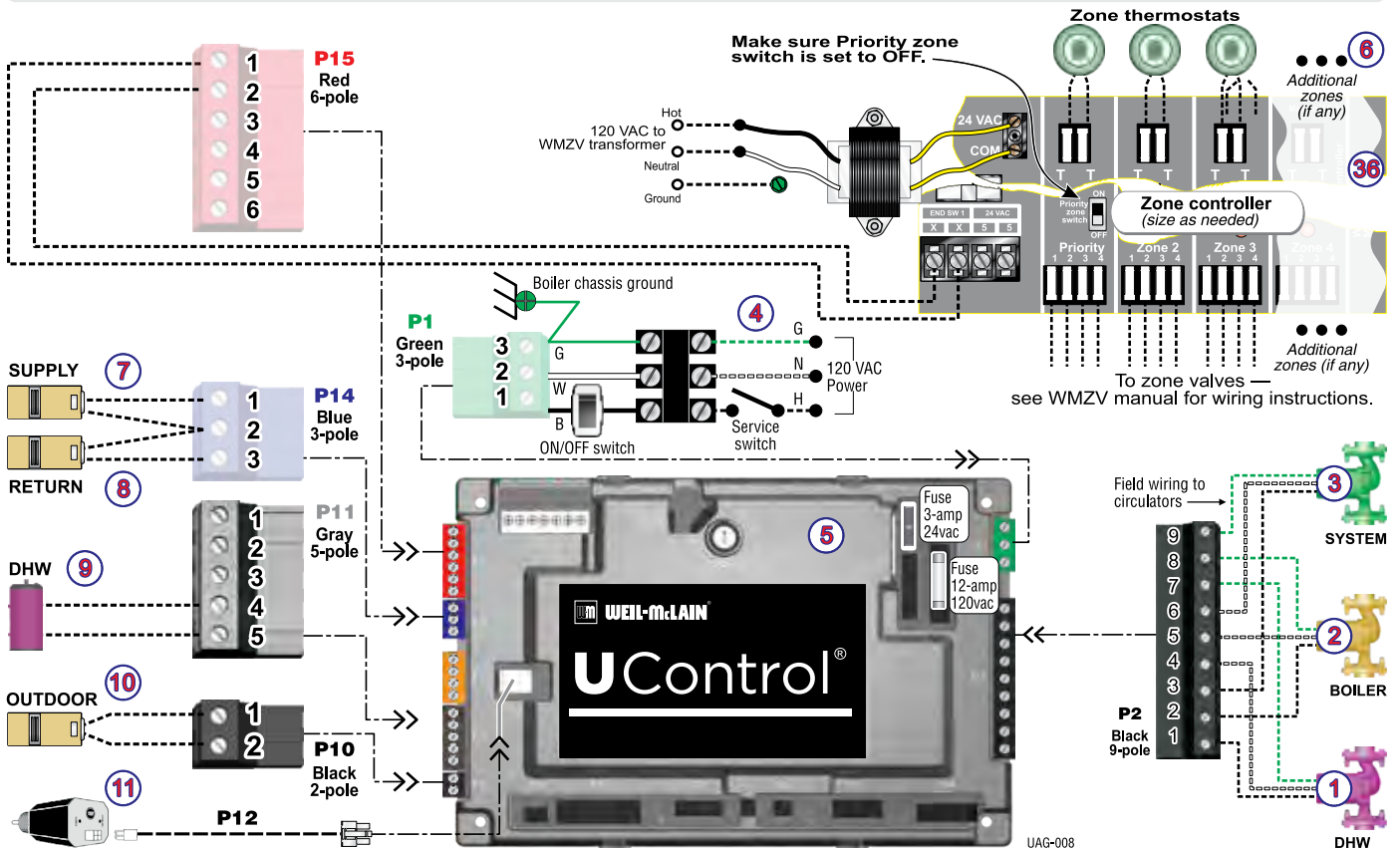



# Application 9

Multi-zone BASEBOARD (Circulators + WMCR controller) | DHW (Direct-connected)

## Purpose

- Space heating with multiple baseboard zones.
- Zoning with circulators.
- DHW piped directly to the boiler.
- DHW priority — space heating and heater exchanger heating are disabled during call for heat from water heater.

## U-Control setting notes

- See the table at right for required and optional settings.
- To see the navigation sequence to access the BOILER SETTINGS and SYSTEM SETTINGS menus, see page 7.
- Select DHW DIRECT for the DHW BOILER PRIORITY 1. This informs the control that the DHW tank is directly connected to the boiler.

## Circulators and piping

- Piping must be primary/secondary as shown.

### DHW

- DHW circulator must be selected to handle the pressure drop through the Ultra boiler, water heater and piping — see boiler manual for recommended sizing. DHW circulator supplied by installer.
- For some large indirect water heaters, the required flow rate may require piping the water heater differently — see boiler manual and other applications in this guide.
- U-Control is set for DHW priority — space heating will be discontinued during a call for DHW.

### BASEBOARD

- Size for required flow.
- Baseboard zone circulators supplied by installer.
- Multiple zones.

### BOILER

- See boiler manual for sizing.
- Circulator shipped loose with boiler.
- Boiler loop piping can be provided using optional Easy-Up Manifolds, available from Weil-McLain (see page 5).

## Wiring

- Connect field wiring as shown on next page.
- This application applies only to multiple-zone space heating, using a zone controller.
- For circulators connected to the U-Control, the maximum circulator load is 2.2 amps each — if load is higher, provide a circulator relay or contactor for circulator power.
- Provide a circulator zone controller.

<b>U-CONTROL SETTINGS</b>			
(SEE NAVIGATION FLOW BELOW)		<b>XXX</b>	— VALUE MUST BE SET (OR VERIFIED) AS INDICATED
		<b>D</b>	— DEFAULT ACCEPTABLE; CHANGE ONLY IF DESIRED
<b>BOILER SETTINGS</b>			
BOILER MODEL		Verify model number is correct	
HIGH ALTITUDE		Set to YES if high altitude	
HIGH LIMIT		D	
WWSD TEMP		DEFAULT (70 °F) OR AS REQUIRED	
ADJUST OUTDOOR		DEFAULT (0 °F) OR AS REQUIRED	
ADD'L HEAT DEMAND TYPE		D	
ADD'L HEAT DEMAND TIME		D	
<b>SYSTEM SETTINGS</b>			
<b>BOILER PRIORITY 1 DHW</b>	SYSTEM TYPE	Select from list	DHW Direct
	TEMPERATURES	Max Supply	190 F
		Max OD Reset	D
		Min OD Reset	D
		Modulate On Diff	D
	TIMES	Modulate Off Diff	D
		Max On Time	D
		Boost Interval Prepump Time: Postpump Time:	D D D
	CIRCULATORS	Circulator 1	ON
		Circulator 2	OFF
Circulator 3		OFF	
MAXIMUM RATE		D	
MINIMUM RATE		D	
<b>BOILER PRIORITY 2 Baseboard (Finned tube or cast iron)</b>	SYSTEM TYPE	Select from list	FTB or CIB
	TEMPERATURES	Max Supply	180 F
		Min Supply	D
		Max OD Reset	D (70F) or as req'd
		Min OD Reset	D (0F) or as req'd
	TIMES	Modulate On Diff	D
		Modulate Off Diff	D
		Max On Time Min On Time Boost Interval Prepump Time: Postpump Time:	D D D D D
	CIRCULATORS	Circulator 1	OFF
		Circulator 2	ON
Circulator 3		OFF	
MAXIMUM RATE		D	
MINIMUM RATE		D	
<b>BOILER PRIORITY 3 Not used</b>	SYSTEM TYPE	Select from list	D
	TEMPERATURES	Max Supply	D
		Min Supply	D
		Max OD Reset	D
		Min OD Reset	D
	TIMES	Modulate On Diff	D
		Modulate Off Diff	D
		Min On Time Boost Interval Prepump Time: Postpump Time:	D D D D
	CIRCULATORS	Circulator 1	D
		Circulator 2	D
Circulator 3		D	
MAXIMUM RATE		D	
MINIMUM RATE		D	
<b>CIRCULATOR EXERCISING</b>	Circulator 1	D	
	Circulator 2	D	
	Circulator 3	D	
<b>FREEZE PROTECT CIRC</b>	Circulator 1	D	
	Circulator 2	D	
	Circulator 3	D	



## PIPING

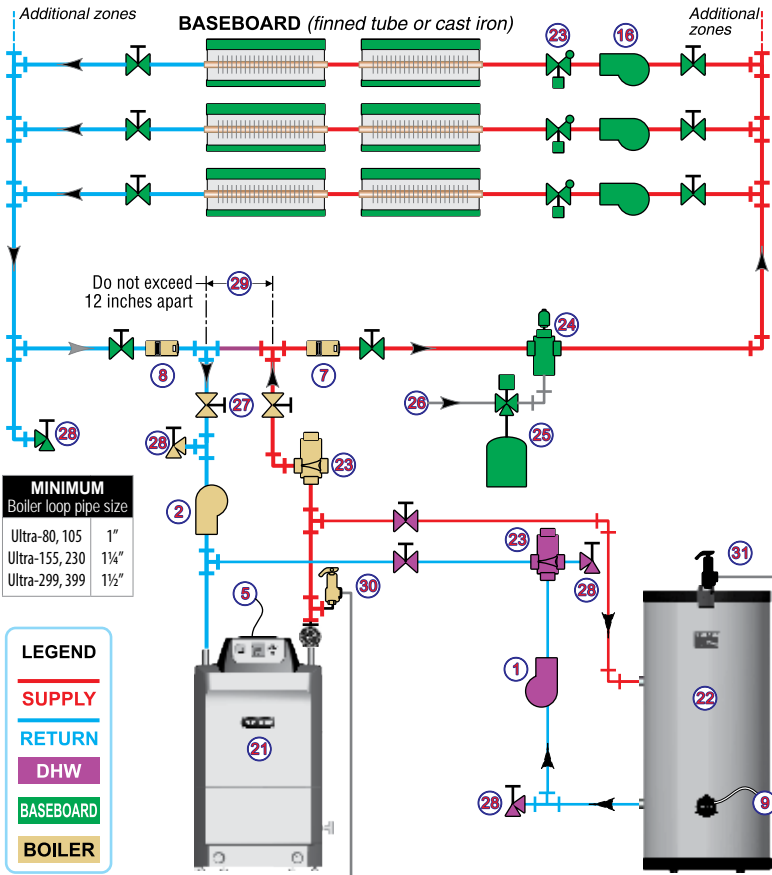

## LEGEND

\* = Supplied by installer

- DHW circulator \*
- BOILER circulator (shipped loose with boiler)
- 120VAC power supply, 15-amp minimum rating
- U-Control
- Baseboard zone thermostats \*
- Supply temperature sensor — strap to supply line
- Return temperature sensor — strap to return line
- DHW tank aquastat or sensor\*
- Outdoor temperature sensor (supplied with boiler; install if U-Control will be set for outdoor reset operation)
- Low water cutoff (if used) \*
- Circulator zone controller \*
- Baseboard zone circulators \*
- Ultra boiler
- Indirect water heater \*
- Flow/check valves \*
- Air separator with automatic air vent \*
- Diaphragm-type expansion tank \*
- Fresh water supply — install per applicable codes \*
- Isolation valves \*
- Purge/drain valves \*
- Secondary piping connection for boiler loop \*
- Boiler relief valve (install per boiler manual)
- DHW Temperature and Pressure relief valve (install per boiler manual)

## FIELD WIRING

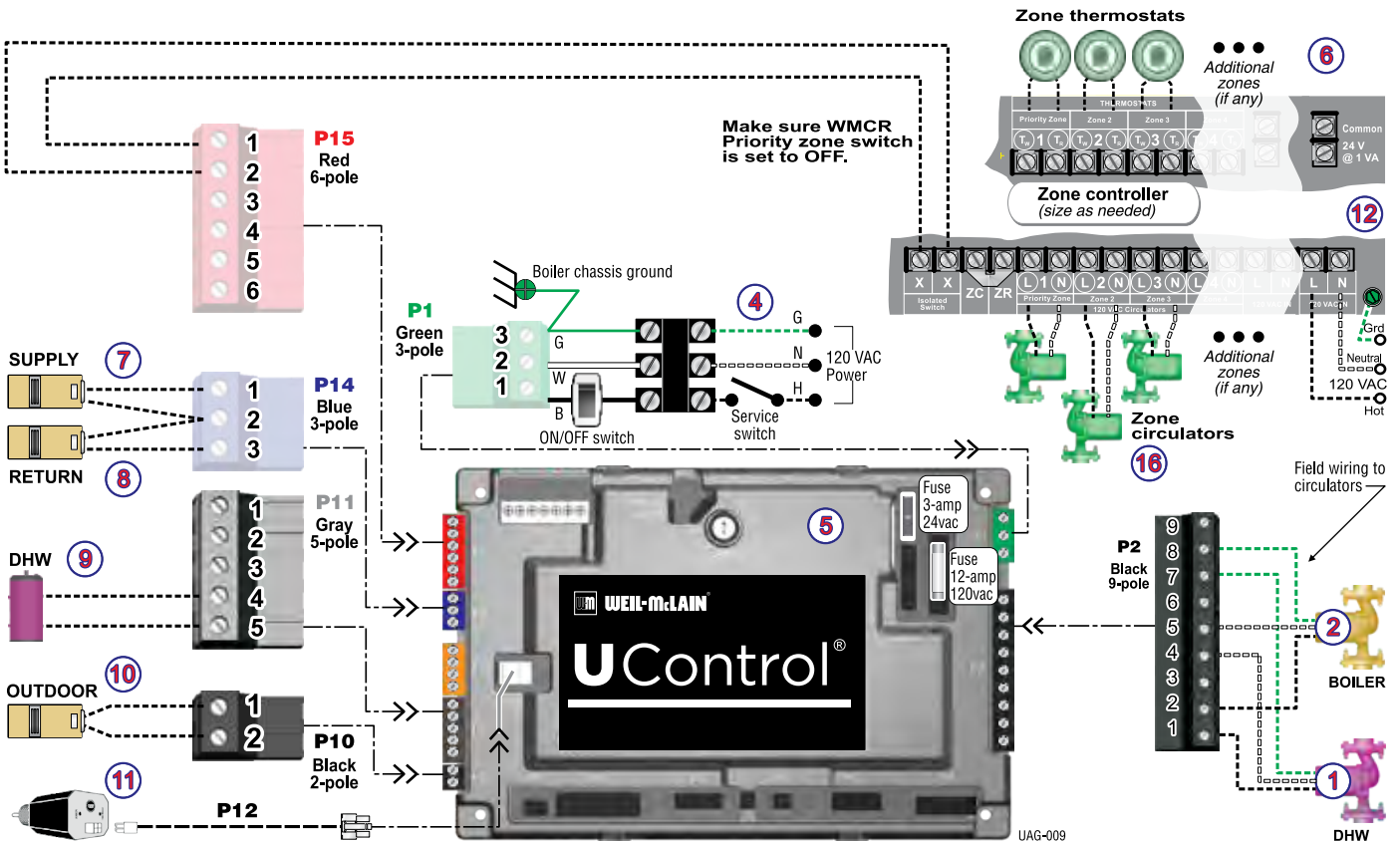



# Application 10

Multi-zone FAN COILS (Circs. + WMCR contr.) | DHW (Direct-connected) | Small RADIANT zone (<30% of total heat loss)

## Purpose

- Space heating with multiple fan coil zones, circulator zoning.
- Single radiant zone for small space (heating load less than 30% of total heat loss — alternatively, see Application 7a, which does not limit load sizes). Fan coil zones are disabled during radiant call for heat.
- DHW piped directly to the boiler.
- DHW priority — space heating and heater exchanger heating are disabled during call for heat from water heater.

## U-Control setting notes

- See the table at right for required and optional settings.
- To see the navigation sequence to access the BOILER SETTINGS and SYSTEM SETTINGS menus, see page 7.
- Select DHW DIRECT for the DHW BOILER PRIORITY 1. This informs the control that the DHW tank is directly connected to the boiler.

## Circulators and piping

- Piping must be primary/secondary as shown.

### DHW

- DHW circulator must be selected to handle the pressure drop through the Ultra boiler, water heater and piping — see boiler manual for recommended sizing. DHW circulator supplied by installer.
- For some large indirect water heaters, the required flow rate may require piping the water heater differently — see boiler manual and other applications in this guide.
- U-Control is set for DHW priority — space heating will be discontinued during a call for DHW.

### FAN COIL

- Multiple zones with circulators controlled by a zone controller.
- Size circulators for required flow. Fan coil circulators supplied by installer.

### RADIANT

- Radiant load must be less than 30% of total heat loss.
- Size circulator for required flow. Radiant circulator supplied by installer.

#### NOTICE

See **Application 7a**, page 22, for radiant heating using independent temperature control for the radiant zone, with no limit to the radiant load.

### BOILER

- See boiler manual for sizing.
- Circulator shipped loose with boiler.
- Boiler loop piping can be provided using optional Easy-Up Manifolds, available from Weil-McLain (see page 5).

## Wiring

- Connect field wiring as shown on next page.
- This application applies only to multiple-zone space heating, using a zone controller.
- For circulators connected to the U-Control, the maximum circulator load is 2.2 amps each — if load is higher, provide a circulator relay or contactor for circulator power.
- Provide a circulator zone controller to control fan coil zone circulators.
- Provide a single-pole normally-closed contact relay, 120 VAC coil, to disable fan coil zones during radiant call for heat.

#### NOTICE

The single-pole relay can be omitted if the fan coil units are equipped with minimum temperature aquastats.

<b>U-CONTROL SETTINGS</b>			
(SEE NAVIGATION FLOW BELOW)		<b>XXX</b>	— VALUE MUST BE SET (OR VERIFIED) AS INDICATED
		<b>D</b>	— DEFAULT ACCEPTABLE; CHANGE ONLY IF DESIRED
<b>BOILER SETTINGS</b>			
BOILER MODEL		Verify model number is correct	
HIGH ALTITUDE		Set to YES if high altitude	
HIGH LIMIT		D	
WWSD TEMP		DEFAULT (70 °F) OR AS REQUIRED	
ADJUST OUTDOOR		DEFAULT (0 °F) OR AS REQUIRED	
ADD'L HEAT DEMAND TYPE		D	
ADD'L HEAT DEMAND TIME		D	
<b>SYSTEM SETTINGS</b>			
<b>BOILER PRIORITY 1 DHW</b>	SYSTEM TYPE	Select from list	DHW Direct
	TEMPERATURES	Max Supply	190 F
		Max OD Reset	D
		Min OD Reset	D
		Modulate On Diff	D
	TIMES	Modulate Off Diff	D
		Max On Time	D
		Boost Interval	D
	CIRCULATORS	Prepump Time:	D
		Circulator 1	ON
Circulator 2		OFF	
MAXIMUM RATE	Circulator 3	OFF	
	MINIMUM RATE		D
<b>BOILER PRIORITY 2 Fan coil zones</b>	SYSTEM TYPE	Select from list	FCL
	TEMPERATURES	Max Supply	190 F
		Min Supply	D
		Max OD Reset	D (70F) or as req'd
		Min OD Reset	D (0F) or as req'd
	TIMES	Modulate On Diff	D
		Modulate Off Diff	D
		Max On Time	D
	CIRCULATORS	Min On Time	D
		Boost Interval	D
Prepump Time:		D	
MAXIMUM RATE	Postpump Time:	D	
	MINIMUM RATE		D
<b>BOILER PRIORITY 3 Radiant zone &lt;30% of total heat loss</b>	SYSTEM TYPE	Select from list	Note 1 (at left)
	TEMPERATURES	Max Supply	As required
		Min Supply	D
		Max OD Reset	D (70F) or as req'd
		Min OD Reset	D (0F) or as req'd
	TIMES	Modulate On Diff	D
		Modulate Off Diff	D
		Min On Time	D
	CIRCULATORS	Boost Interval	D
		Prepump Time:	D
Postpump Time:		D	
MAXIMUM RATE	Circulator 1	OFF	
	MINIMUM RATE		D
CIRCULATOR EXERCISING	Circulator 2	ON	
	Circulator 3	ON	
	FREEZE PROTECT CIRC'S	Circulator 1	D
Circulator 2		D	
Circulator 3		D	



## PIPING

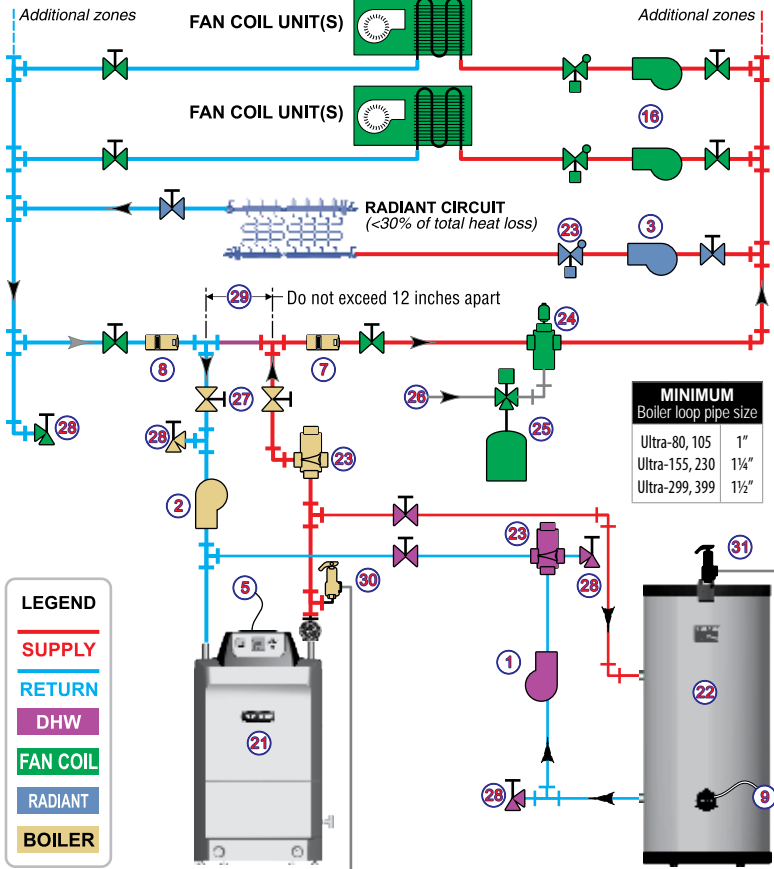

## LEGEND

\* = Supplied by installer

- 1 DHW circulator \*
- 2 BOILER circulator (shipped loose with boiler)
- 3 Radiant zone circulator \*
- 4 120VAC power supply, 15-amp minimum rating
- 5 U-Control
- 6 Fan coil zone thermostats \*
- 7 Supply temperature sensor — strap to supply line
- 8 Return temperature sensor — strap to return line
- 9 DHW tank aquastat or sensor\*
- 10 Outdoor temperature sensor (supplied with boiler; install if U-Control will be set for outdoor reset operation)
- 11 Low water cutoff (if used) \*
- 12 Circulator zone controller \*
- 13 SPST relay with 120 VAC coil \*
- 14 Radiant zone thermostat \*
- 16 Fan coil zone circulators \*
- 21 Ultra boiler
- 22 Indirect water heater \*
- 23 Flow/check valves \*
- 24 Air separator with automatic air vent \*
- 25 Diaphragm-type expansion tank \*
- 26 Fresh water supply — install per applicable codes \*
- 27 Isolation valves \*
- 28 Purge/drain valves \*
- 29 Secondary piping connection for boiler loop \*
- 30 Boiler relief valve (install per boiler manual)
- 31 DHW Temperature and Pressure relief valve (install per boiler manual)



## FIELD WIRING

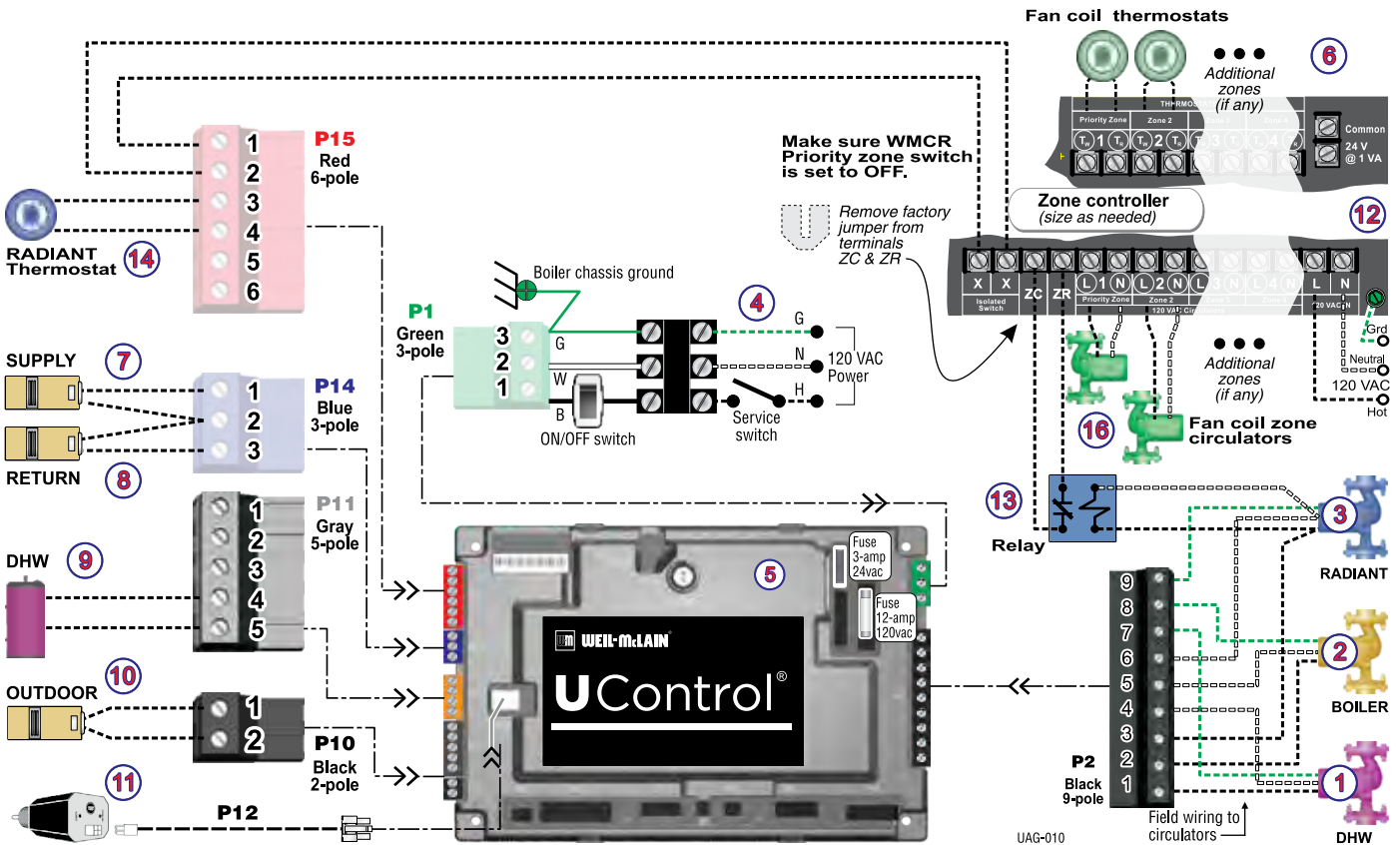



# Application 11

**CAST IRON RADIATORS** | DHW (Direct-connected) | **Small RADIANT zone** (<30% of total heat loss)

## Purpose

- Single cast iron radiator zone.
- Single radiant zone for small space (heating load less than 30% of total heat loss — alternatively, see Application 7a, which does not limit load sizes). Radiator zone is disabled during radiant call for heat.
- DHW piped directly to the boiler.
- DHW priority — space heating is disabled during call for heat from water heater.

## U-Control setting notes

- See the table at right for required and optional settings.
- To see the navigation sequence to access the BOILER SETTINGS and SYSTEM SETTINGS menus, see page 7.
- Select DHW DIRECT for the DHW BOILER PRIORITY 1. This informs the control that the DHW tank is directly connected to the boiler.

## Circulators and piping

- Piping must be primary/secondary as shown.

### DHW

- DHW circulator must be selected to handle the pressure drop through the Ultra boiler, water heater and piping — see boiler manual for recommended sizing. DHW circulator supplied by installer.
- For some large indirect water heaters, the required flow rate may require piping the water heater differently — see boiler manual and other applications in this guide.
- U-Control is set for DHW priority — space heating will be discontinued during a call for DHW.

### RADIATORS

- Size circulator for required flow.
- Radiator zone circulator supplied by installer.

### RADIANT

- Radiant load must be less than 30% of total heat loss.

#### NOTICE

See **Application 7a**, page 22, for radiant heating using independent temperature control for the radiant zone, with no limit to the radiant load.

- Size circulator for required flow. Radiant circulator supplied by installer.

### BOILER

- See boiler manual for sizing.
- Circulator shipped loose with boiler.
- Boiler loop piping can be provided using optional Easy-Up Manifolds, available from Weil-McLain (see page 5).

## Wiring

- Connect field wiring as shown on next page.
- For circulators connected to the U-Control, the maximum circulator load is 2.2 amps each — if load is higher, provide a circulator relay or contactor for circulator power.
- Provide a relay to operate radiator circulator(s) and provide call for radiator zone heating to U-Control input.
- If using multiple zones, provide components and wiring needed to operate zone components and provide call for heat to the U-control input.

<b>U-CONTROL SETTINGS</b>			
(SEE NAVIGATION FLOW BELOW)		<b>xxx</b>	— VALUE MUST BE SET (OR VERIFIED) AS INDICATED
		<b>D</b>	— DEFAULT ACCEPTABLE; CHANGE ONLY IF DESIRED
<b>BOILER SETTINGS</b>			
BOILER MODEL	Verify model number is correct		
HIGH ALTITUDE	Set to YES if high altitude		
HIGH LIMIT	D		
WWSD TEMP	DEFAULT (70 °F) OR AS REQUIRED		
ADJUST OUTDOOR	DEFAULT (0 °F) OR AS REQUIRED		
ADD'L HEAT DEMAND TYPE	D		
ADD'L HEAT DEMAND TIME	D		
<b>SYSTEM SETTINGS</b>			
<b>BOILER PRIORITY 1 DHW</b>	SYSTEM TYPE	Select from list	DHW Direct
	TEMPERATURES	Max Supply	190 F
		Max OD Reset	D
		Min OD Reset	D
		Modulate On Diff	D
	TIMES	Modulate Off Diff	D
		Max On Time	D
		Boost Interval	D
	CIRCULATORS	Prepump Time:	D
		Postpump Time:	D
Circulator 1		ON	
MAXIMUM RATE	Circulator 2	OFF	
	Circulator 3	OFF	
MINIMUM RATE	D		
<b>BOILER PRIORITY 2 Radiator zone</b>	SYSTEM TYPE	Select from list	CIR
	TEMPERATURES	Max Supply	180 F
		Min Supply	D
		Max OD Reset	D (70F) or as req'd
		Min OD Reset	D (0F) or as req'd
	TIMES	Modulate On Diff	D
		Modulate Off Diff	D
		Max On Time	D
	CIRCULATORS	Min On Time	D
		Boost Interval	D
Prepump Time:		D	
MAXIMUM RATE	Postpump Time:	D	
	Circulator 1	OFF	
MINIMUM RATE	Circulator 2	ON	
	Circulator 3	OFF	
<b>BOILER PRIORITY 3 Radiant zone &lt;30% of total heat loss</b>	SYSTEM TYPE	Select from list	Note 1 (at left)
	TEMPERATURES	Max Supply	As required
		Min Supply	D
		Max OD Reset	D (70F) or as req'd
		Min OD Reset	D (0F) or as req'd
	TIMES	Modulate On Diff	D
		Modulate Off Diff	D
		Min On Time	D
	CIRCULATORS	Boost Interval	D
		Prepump Time:	D
Postpump Time:		D	
MAXIMUM RATE	Circulator 1	OFF	
	Circulator 2	ON	
MINIMUM RATE	Circulator 3	ON	
	CIRCULATOR EXERCISING	Circulator 1	D
FREEZE PROTECT CIRC'S	Circulator 2	D	
	Circulator 3	D	
	Circulator 1	D	
	Circulator 2	D	
	Circulator 3	D	



## PIPING

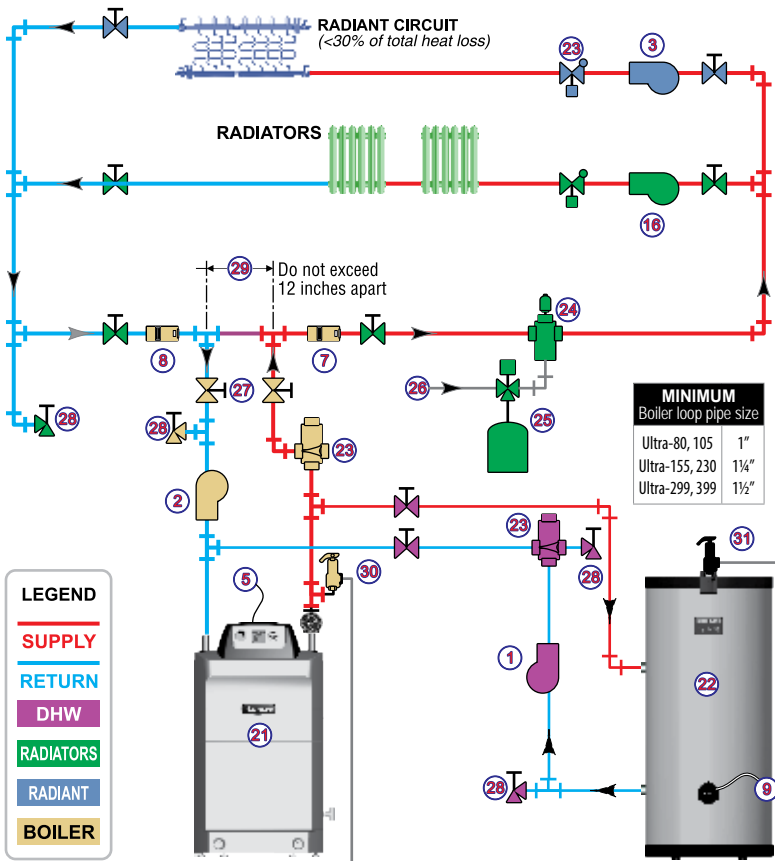

## LEGEND

\* = Supplied by installer

- 1 DHW circulator \*
- 2 BOILER circulator (shipped loose with boiler)
- 3 Radiant circuit circulator \*
- 4 120VAC power supply, 15-amp minimum rating
- 5 U-Control
- 6 Radiator zone thermostat \*
- 7 Supply temperature sensor — strap to supply line
- 8 Return temperature sensor — strap to return line
- 9 DHW tank aquastat or sensor\*
- 10 Outdoor temperature sensor (supplied with boiler; install if U-Control will be set for outdoor reset operation)
- 11 Low water cutoff (if used) \*
- 14 Radiant thermostat \*
- 15 2-pole relay \*
- 16 Radiator zone circulator \*
- 21 Ultra boiler
- 22 Indirect water heater \*
- 23 Flow/check valves \*
- 24 Air separator with automatic air vent \*
- 25 Diaphragm-type expansion tank \*
- 26 Fresh water supply — install per applicable codes \*
- 27 Isolation valves \*
- 28 Purge/drain valves \*
- 29 Secondary piping connection for boiler loop \*
- 30 Boiler relief valve (install per boiler manual)
- 31 DHW Temperature and Pressure relief valve (install per boiler manual)

## FIELD WIRING

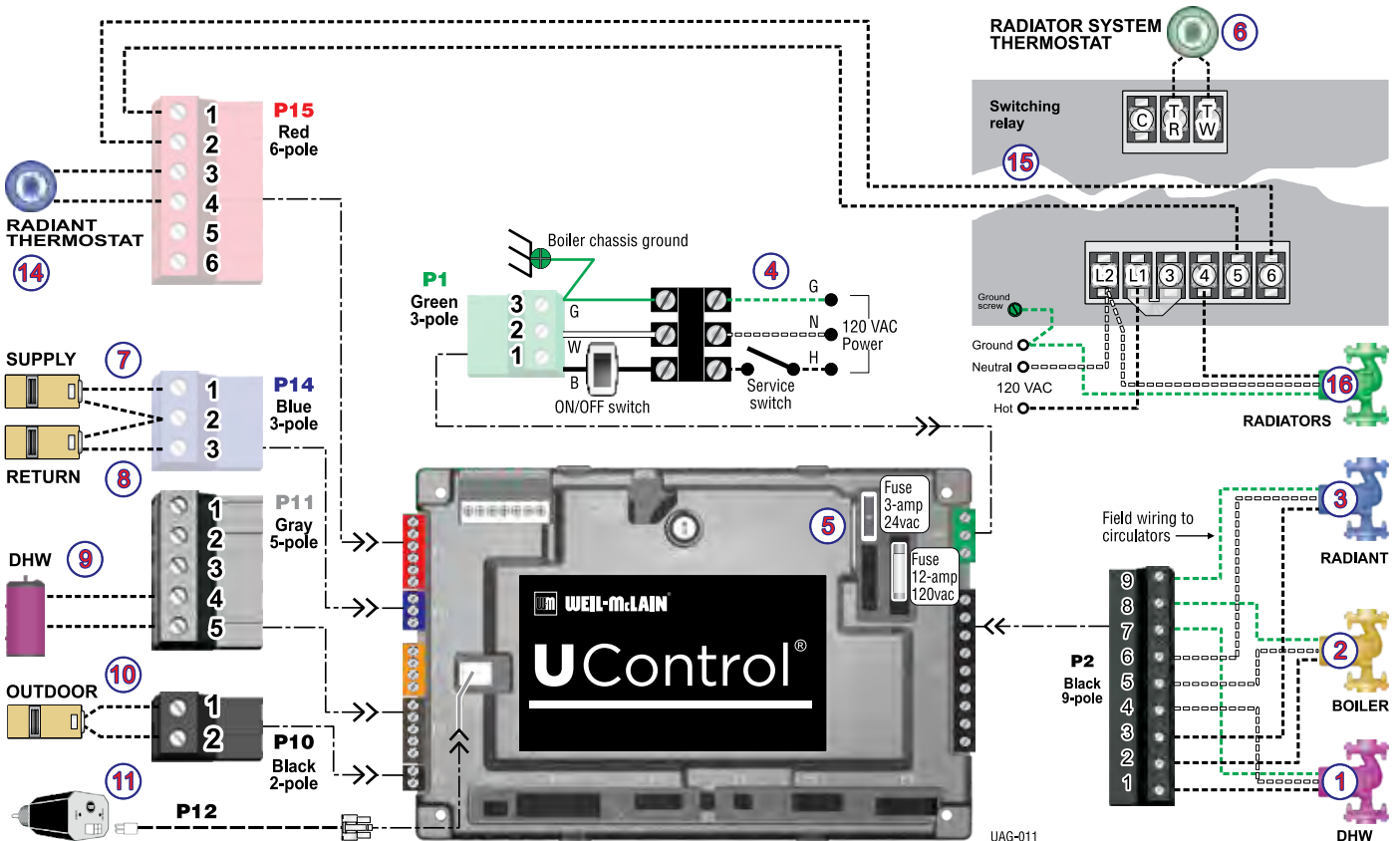



# Application 12

FAN COIL zone | BASEBOARD zone | Small RADIANT zone (<30% of total heat loss)

## Purpose

- Space heating with a single zone of baseboard, single zone of radiant and single zone of fan coil.
- The radiant load must be no more than 30% of the total heating load to use the control strategy of this application. Alternatively, see Application 7a, which does not limit load sizes.
- Zoning with circulators.

## U-Control setting notes

- See the table at right for required and optional settings.
- To see the navigation sequence to access the BOILER SETTINGS and SYSTEM SETTINGS menus, see page 7.

## Circulators and piping

- Piping must be primary/secondary as shown.

### FAN COIL

- Size circulator for required flow.
- Fan coil circulator supplied by installer.

### BASEBOARD

- Size circulator for required flow.
- Baseboard circulator supplied by installer.

### RADIANT

- Radiant load must be less than 30% of total heat loss.

#### NOTICE

See **Application 7a**, page 22, for radiant heating using independent temperature control for the radiant zone, with no limit to the radiant load.

- Size circulator for required flow. Radiant circulator supplied by installer.

### BOILER

- See boiler manual for sizing.
- Circulator shipped loose with boiler.
- Boiler loop piping can be provided using optional Easy-Up Manifolds, available from Weil-McLain (see page 5).

## Wiring

- Connect field wiring as shown on next page.
- For circulators connected to the U-Control, the maximum circulator load is 2.2 amps each — if load is higher, provide a circulator relay or contactor for circulator power.
- Provide a relay to operate baseboard circulator and provide call for heat to U-Control.

<b>U-CONTROL SETTINGS</b> (SEE NAVIGATION FLOW BELOW)		XXX	— VALUE MUST BE SET (OR VERIFIED) AS INDICATED
		D	— DEFAULT ACCEPTABLE; CHANGE ONLY IF DESIRED
<b>BOILER SETTINGS</b>			
BOILER MODEL		Verify model number is correct	
HIGH ALTITUDE		Set to YES if high altitude	
HIGH LIMIT		D	
WWSD TEMP		DEFAULT (70 °F) OR AS REQUIRED	
ADJUST OUTDOOR		DEFAULT (0 °F) OR AS REQUIRED	
ADD'L HEAT DEMAND TYPE		TYPE 1	
ADD'L HEAT DEMAND TIME		DEFAULT (0 MINUTES)	
<b>SYSTEM SETTINGS</b>			
<b>BOILER PRIORITY 1</b>  Fan coil zone	SYSTEM TYPE	Select from list	FCL
	TEMPERATURES	Max Supply	190 F
		Min Supply	D
		Max OD Reset	Default
		Min OD Reset	Default
		Modulate On Diff	D
		Modulate Off Diff	D
	TIMES	Max On Time	D (30 minutes)
	CIRCULATORS	Circulator 1	ON
		Circulator 2	ON
Circulator 3		OFF	
MAXIMUM RATE		D	
MINIMUM RATE		D	
<b>BOILER PRIORITY 2</b>  Baseboard (Finned tube or cast iron)	SYSTEM TYPE	Select from list	FTB or CIB
	TEMPERATURES	Max Supply	180 F
		Min Supply	D
		Max OD Reset	Default
		Min OD Reset	Default
		Modulate On Diff	D
		Modulate Off Diff	D
	TIMES	Max On Time	D (30 minutes)
	CIRCULATORS	Circulator 1	OFF
		Circulator 2	ON
Circulator 3		OFF	
MAXIMUM RATE		D	
MINIMUM RATE		D	
<b>BOILER PRIORITY 3</b>  Radiant zone <30% of total heat loss	SYSTEM TYPE	Select from list	Note 1 (at left)
	TEMPERATURES	Max Supply	As required
		Min Supply	D
		Max OD Reset	Default
		Min OD Reset	Default
		Modulate On Diff	D
		Modulate Off Diff	D
	TIMES	Min On Time	D
	CIRCULATORS	Circulator 1	OFF
		Circulator 2	ON
Circulator 3		ON	
MAXIMUM RATE		D	
MINIMUM RATE		D	
CIRCULATOR EXERCISING	Circulator 1	D	
	Circulator 2	D	
	Circulator 3	D	
FREEZE PROTECT CIRC	Circulator 1	D	
	Circulator 2	D	
	Circulator 3	D	

**Note 1 —**  
Select system type:  
RSG = Slab on grade  
RTS = Thin slab  
RSU = Below floor  
RAF = Above floor





## PIPING

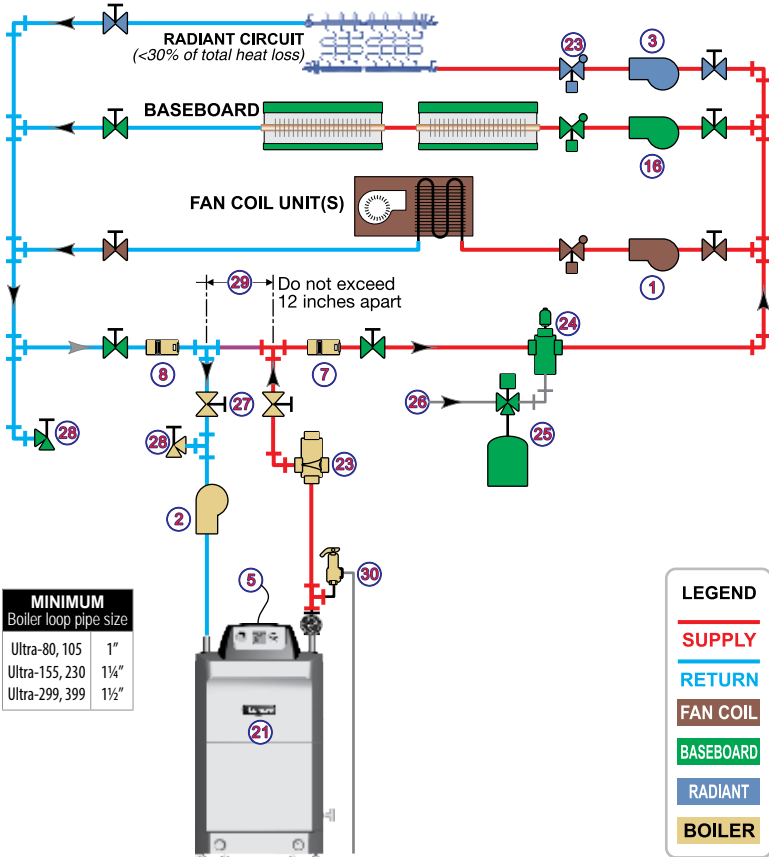

MINIMUM Boiler loop pipe size	
Ultra-80, 105	1"
Ultra-155, 230	1¼"
Ultra-299, 399	1½"



## LEGEND

\* = Supplied by installer

- 1 Fan coil zone circulator \*
- 2 BOILER circulator (shipped loose with boiler)
- 3 Radiant zone circulator \*
- 4 120VAC power supply, 15-amp minimum rating
- 5 U-Control
- 6 Baseboard zone thermostat \*
- 7 Supply temperature sensor — strap to supply line
- 8 Return temperature sensor — strap to return line
- 9 Fan coil zone thermostat \*
- 10 Outdoor temperature sensor (supplied with boiler; install if U-Control will be set for outdoor reset operation)
- 11 Low water cutoff (if used) \*
- 14 Radiant thermostat \*
- 15 2-pole relay \*
- 16 Baseboard zone circulator \*
- 21 Ultra boiler
- 23 Flow/check valves \*
- 24 Air separator with automatic air vent \*
- 25 Diaphragm-type expansion tank \*
- 26 Fresh water supply — install per applicable codes \*
- 27 Isolation valves \*
- 28 Purge/drain valves \*
- 29 Secondary piping connection for boiler loop \*
- 30 Boiler relief valve (install per boiler manual)

## FIELD WIRING

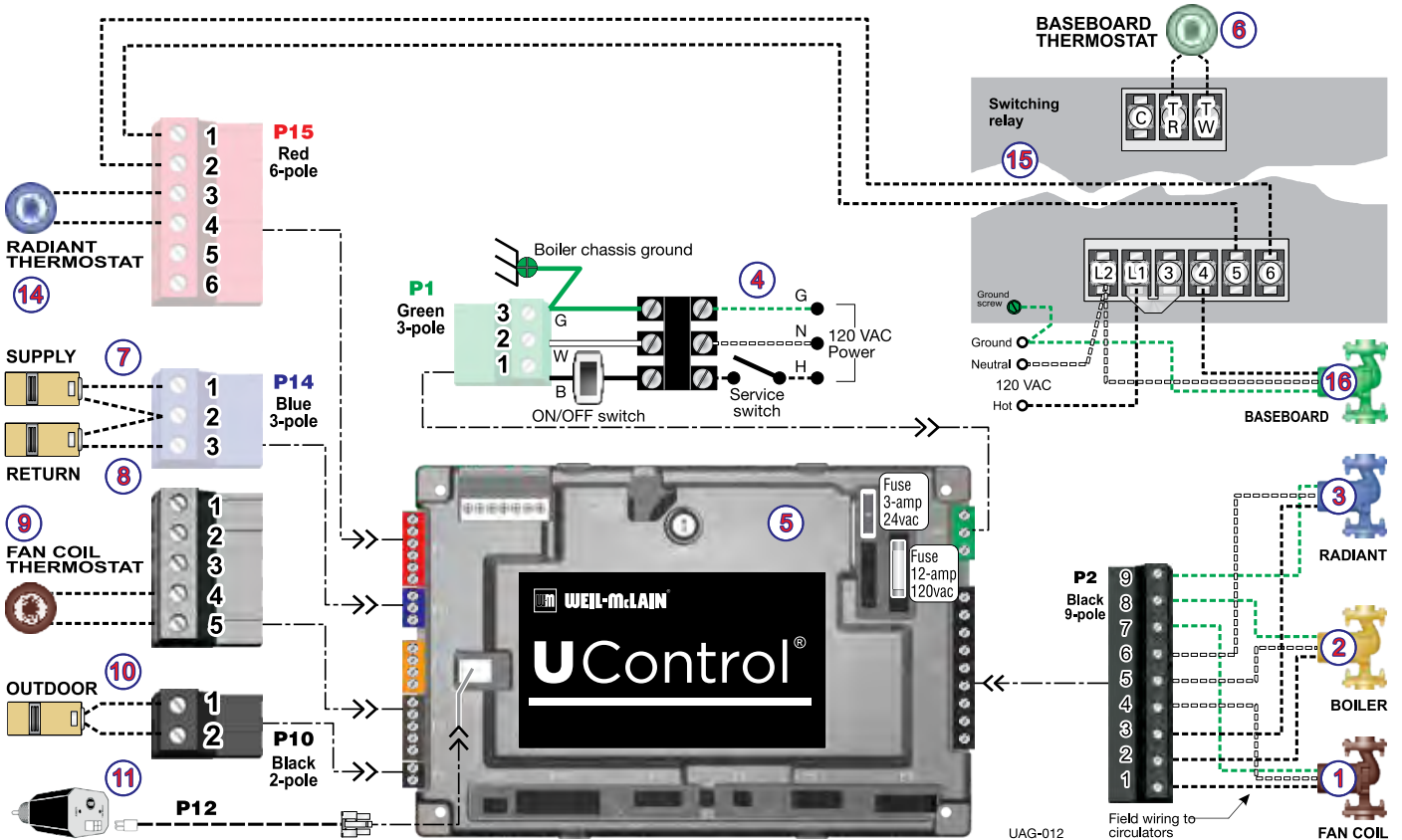



# Application 13

Single-zone BASEBOARD | DHW (System, as zone)

## Purpose

- Space heating with single zone of baseboard (finned tube or cast iron). This application can be adapted for multiple baseboard zones if piping components and controls are added to control the zone circulators or zone valves and provide a call for heat signal to the U-Control.
- DHW piped as a separate zone.
- DHW priority — space heating is disabled during call for heat from water heater.

## U-Control settings

- See the table at right for required and optional settings.
- To see the navigation sequence to access the BOILER SETTINGS and SYSTEM SETTINGS menus, see page 7.
- Select DHW SYSTEM for the DHW BOILER PRIORITY 1. This informs the control that the DHW tank is a system zone, not directly connected to the boiler.

## Circulators and piping

- Piping must be primary/secondary as shown.

DHW
<ul style="list-style-type: none"> <li>• DHW circulator must be sized for required flow and head loss.</li> <li>• DHW circulator supplied by installer.</li> <li>• U-Control is set for DHW priority — space heating will be discontinued during a call for DHW.</li> </ul>

BASEBOARD
<ul style="list-style-type: none"> <li>• Single zone. Multiple zones can be used if zone controller and piping components are added.</li> <li>• Size circulator for required flow.</li> <li>• Baseboard circulator supplied by installer.</li> </ul>

BOILER
<ul style="list-style-type: none"> <li>• See boiler manual for sizing.</li> <li>• Circulator shipped loose with boiler.</li> <li>• Boiler loop piping can be provided using optional Easy-Up Manifolds, available from Weil-McLain (see page 5).</li> </ul>

## Wiring

- Connect field wiring as shown on next page.
- For circulators connected to the U-Control, the maximum circulator load is 2.2 amps each — if load is higher, provide a circulator relay or contactor for circulator power.
- If using multiple zones of baseboard, provide components and wiring needed to operate zone components and provide call for heat to the U-control input.

<b>U-CONTROL SETTINGS</b>			
(SEE NAVIGATION FLOW BELOW)		<b>XXX</b> — VALUE MUST BE SET (OR VERIFIED) AS INDICATED	<b>D</b> — DEFAULT ACCEPTABLE; CHANGE ONLY IF DESIRED
<b>BOILER SETTINGS</b>			
BOILER MODEL		Verify model number is correct	
HIGH ALTITUDE		Set to YES if high altitude	
HIGH LIMIT		D	
WWSD TEMP		DEFAULT (70 °F) OR AS REQUIRED	
ADJUST OUTDOOR		DEFAULT (0 °F) OR AS REQUIRED	
ADD'L HEAT DEMAND TYPE		D	
ADD'L HEAT DEMAND TIME		D	
<b>SYSTEM SETTINGS</b>			
<b>BOILER PRIORITY 1 DHW</b>	SYSTEM TYPE	Select from list	DHW SYSTEM
	TEMPERATURES	Max Supply	190 F
		Max OD Reset	D
		Min OD Reset	D
		Modulate On Diff	D
	TIMES	Max On Time	D
		Boost Interval	D
		Prepump Time: Postpump Time:	D
	CIRCULATORS	Circulator 1	ON
		Circulator 2	ON
Circulator 3		OFF	
MAXIMUM RATE		D	
MINIMUM RATE		D	
<b>BOILER PRIORITY 2 Baseboard (Finned tube or cast iron)</b>	SYSTEM TYPE	Select from list	FTB or CIB
	TEMPERATURES	Max Supply	180 F
		Min Supply	D
		Max OD Reset	D (70F) or as req'd
		Min OD Reset	D (0F) or as req'd
	TIMES	Modulate On Diff	D
		Modulate Off Diff	D
		Max On Time Min On Time Boost Interval Prepump Time: Postpump Time:	D
	CIRCULATORS	Circulator 1	OFF
		Circulator 2	ON
Circulator 3		ON	
MAXIMUM RATE		D	
MINIMUM RATE		D	
<b>BOILER PRIORITY 3 Not used</b>	SYSTEM TYPE	Select from list	D
	TEMPERATURES	Max Supply	D
		Min Supply	D
		Max OD Reset	D
		Min OD Reset	D
	TIMES	Modulate On Diff	D
		Modulate Off Diff	D
		Min On Time Boost Interval Prepump Time: Postpump Time:	D
	CIRCULATORS	Circulator 1	D
		Circulator 2	D
Circulator 3		D	
MAXIMUM RATE		D	
MINIMUM RATE		D	
<b>CIRCULATOR EXERCISING</b>	Circulator 1	D	
	Circulator 2	D	
	Circulator 3	D	
<b>FREEZE PROTECT CIRC</b>	Circulator 1	D	
	Circulator 2	D	
	Circulator 3	D	



**PIPING**

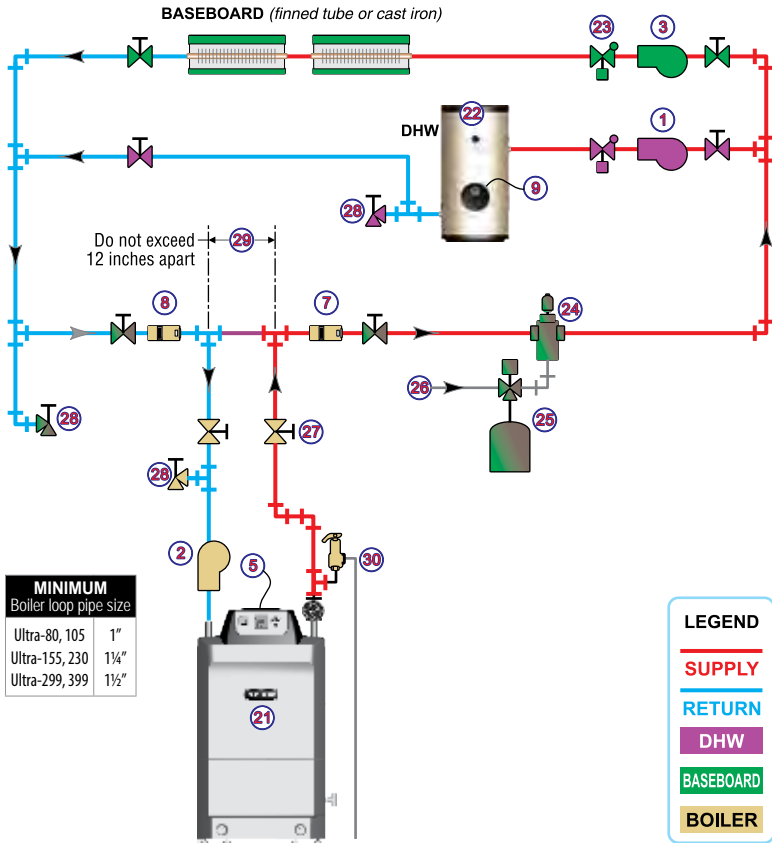

**LEGEND**

\* = Supplied by installer

- 1 DHW circulator \*
- 2 BOILER circulator (shipped loose with boiler)
- 3 Baseboard circulator \*
- 4 120VAC power supply, 15-amp minimum rating
- 5 U-Control
- 6 Baseboard thermostat \*
- 7 Supply temperature sensor — strap to supply line
- 8 Return temperature sensor — strap to return line
- 9 DHW tank aquastat \*
- 10 Outdoor temperature sensor (supplied with boiler; install if U-Control will be set for outdoor reset operation)
- 11 Low water cutoff (if used) \*
- 21 Ultra boiler
- 22 Indirect water heater \*
- 23 Flow/check valves \*
- 24 Air separator with automatic air vent \*
- 25 Diaphragm-type expansion tank \*
- 26 Fresh water supply — install per applicable codes \*
- 27 Isolation valves \*
- 28 Purge/drain valves \*
- 29 Secondary piping connection for boiler loop \*
- 30 Boiler relief valve (install per boiler manual)

**FIELD WIRING**

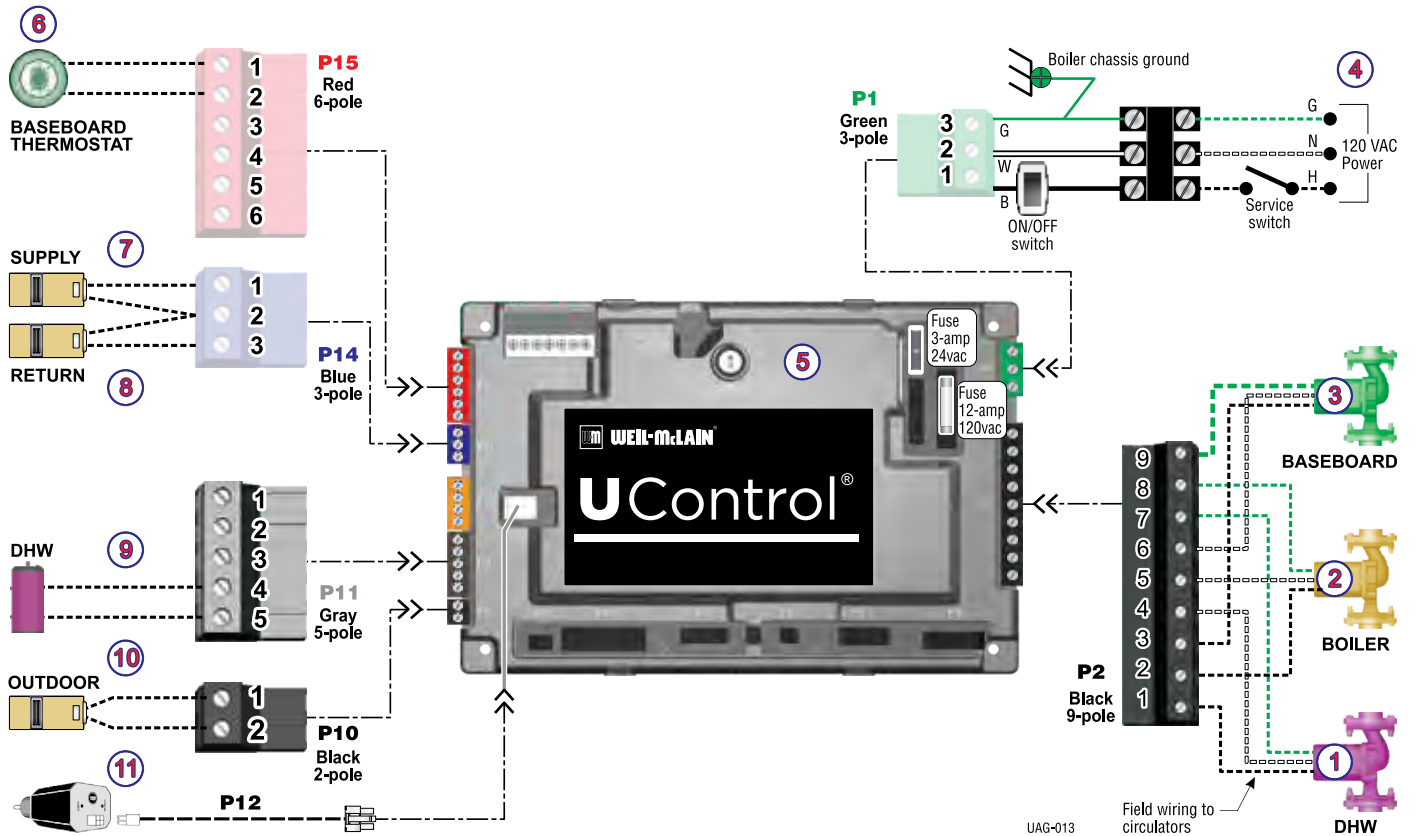



# Application 14

Multi-zone BASEBOARD (Zone valves) | Multi-zone RADIANT (Zone valves) | DHW (Direct-connected)  
(Radiant load must be <30% of total heat loss)

## Purpose

- Space heating with multiple baseboard (finned tube or cast iron) zones and multiple radiant zones, zoning with zone valves.
- The radiant load must be no more than 30% of the total heating load to use the control strategy of this application. Alternatively, see Application 7a, which does not limit load sizes.
- DHW piped directly to the boiler.
- DHW priority — space heating is disabled during call for heat from water heater.

## U-Control setting notes

- See the table at right for required and optional settings.
- To see the navigation sequence to access the BOILER SETTINGS and SYSTEM SETTINGS menus, see page 7.
- Select DHW DIRECT for the DHW BOILER PRIORITY 1. This informs the control that the DHW tank is directly connected to the boiler.

## Circulators and piping

- Piping must be primary/secondary as shown.

### DHW

- DHW circulator must be selected to handle the pressure drop through the Ultra boiler, water heater and piping — see boiler manual for recommended sizing. DHW circulator supplied by installer.
- For some large indirect water heaters, the required flow rate may require piping the water heater differently — see boiler manual and other applications in this guide.
- U-Control is set for DHW priority — space heating will be discontinued during a call for DHW.

### BASEBOARD

- Multiple zones using zone valves.
- Size circulator for required flow.
- Baseboard circulator and zone valves supplied by installer.

### RADIANT

- Multiple zones using zone valves. Radiant load must be less than 30% of total heat loss.

#### NOTICE

See **Application 7a**, page 22, for radiant heating using independent temperature control for the radiant zone, with no limit to the radiant load.

- Size circulator for required flow. Radiant circulator and zone valves supplied by installer.

### BOILER

- See boiler manual for sizing.
- Circulator shipped loose with boiler.
- Boiler loop piping can be provided using optional Easy-Up Manifolds, available from Weil-McLain (see page 5).

## Wiring

- Connect field wiring as shown on next page.
- Zone valve end switches and DHW aquastat activate the U-Control. The U-Control activates the circulators for DHW and radiant circuits.
- This application applies only to multiple-zone space heating, using a zone controller.
- For circulators connected to the U-Control, the maximum circulator load is 2.2 amps each — if load is higher, provide a circulator relay or contactor for circulator power.
- Provide a relay to operate baseboard circulator.

<b>U-CONTROL SETTINGS</b>		XXX	— VALUE MUST BE SET (OR VERIFIED) AS INDICATED
(SEE NAVIGATION FLOW BELOW)		D	— DEFAULT ACCEPTABLE; CHANGE ONLY IF DESIRED
<b>BOILER SETTINGS</b>			
BOILER MODEL		Verify model number is correct	
HIGH ALTITUDE		Set to YES if high altitude	
HIGH LIMIT		D	
WWSD TEMP		DEFAULT (70 °F) OR AS REQUIRED	
ADJUST OUTDOOR		DEFAULT (0 °F) OR AS REQUIRED	
ADD'L HEAT DEMAND TYPE		Type 1	
ADD'L HEAT DEMAND TIME		DEFAULT (0 minutes)	
<b>SYSTEM SETTINGS</b>			
<b>BOILER PRIORITY 1 DHW</b>	SYSTEM TYPE	Select from list	DHW Direct
	TEMPERATURES	Max Supply	190 F
		Max OD Reset	D
		Min OD Reset	D
		Modulate On Diff	D
	TIMES	Max On Time	D (30 minutes)
		Boost Interval	D
		Prepump Time: Postpump Time:	D D
	CIRCULATORS	Circulator 1 Circulator 2 Circulator 3	ON OFF OFF
	MAXIMUM RATE		D
MINIMUM RATE		D	
<b>BOILER PRIORITY 2 Baseboard (Finned tube or cast iron)</b>	SYSTEM TYPE	Select from list	FTB or CIB
	TEMPERATURES	Max Supply	180 F
		Min Supply	D
		Max OD Reset	D (70F) or as req'd
		Min OD Reset	D (0F) or as req'd
	TIMES	Max On Time	D (30 minutes)
		Min On Time	D
		Boost Interval Prepump Time: Postpump Time:	D D D
	CIRCULATORS	Circulator 1 Circulator 2 Circulator 3	OFF ON OFF
	MAXIMUM RATE		D
MINIMUM RATE		D	
<b>BOILER PRIORITY 3 Radiant zones</b>	SYSTEM TYPE	Select from list	Note 1 (at left)
	TEMPERATURES	Max Supply	As required
		Min Supply	D
		Max OD Reset	D (70F) or as req'd
		Min OD Reset	D (0F) or as req'd
	TIMES	Min On Time	D
		Boost Interval	D
		Prepump Time: Postpump Time:	D D
	CIRCULATORS	Circulator 1 Circulator 2 Circulator 3	OFF ON ON
	MAXIMUM RATE		D
MINIMUM RATE		D	
CIRCULATOR EXERCISING	Circulator 1 Circulator 2 Circulator 3	D D D	
FREEZE PROTECT CIRCS	Circulator 1 Circulator 2 Circulator 3	D D D	



## PIPING

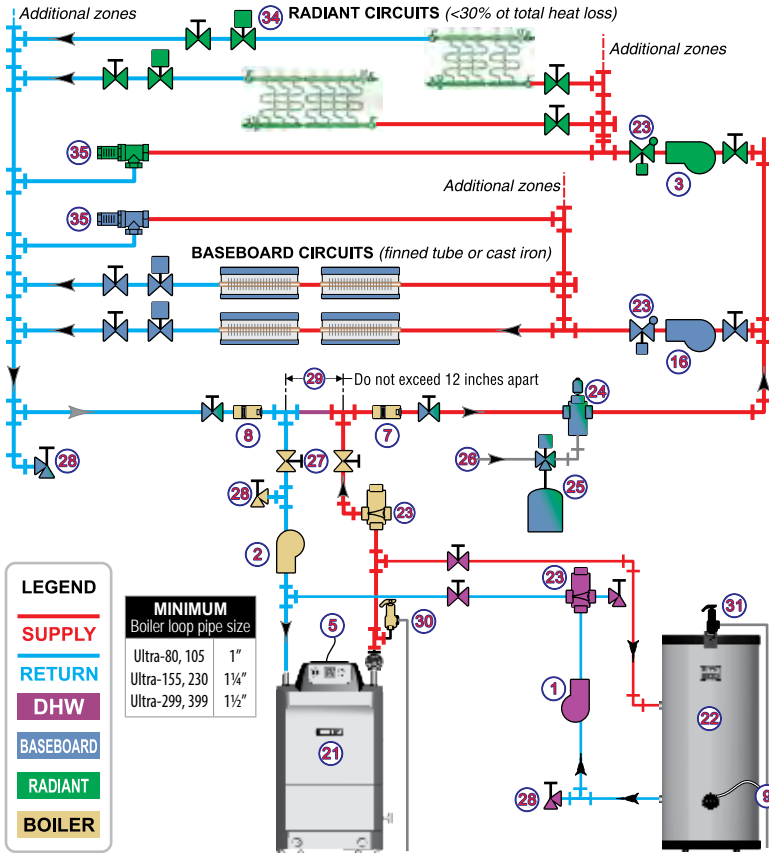

## LEGEND

\* = Supplied by installer

- DHW circulator \*
- BOILER circulator (shipped loose with boiler)
- Radiant circuit circulator \*
- 120VAC power supply, 15-amp minimum rating
- U-Control
- Baseboard zone valve end switches \*
- Supply temperature sensor — strap to supply line
- Return temperature sensor — strap to return line
- DHW tank aquastat or sensor\*
- Outdoor temperature sensor (supplied with boiler; install if U-Control will be set for outdoor reset operation)
- Low water cutoff (if used) \*
- Radiant zone valve end switches \*
- 2-pole relay \*
- Baseboard circuit circulator \*
- Ultra boiler
- Indirect water heater \*
- Flow/check valves \*
- Air separator with automatic air vent \*
- Diaphragm-type expansion tank \*
- Fresh water supply — install per applicable codes \*
- Isolation valves \*
- Purge/drain valves \*
- Secondary piping connection for boiler loop \*
- Boiler relief valve (install per boiler manual)
- DHW Temperature and Pressure relief valve (install per boiler manual)
- Zone valves \*
- Bypass pressure regulator \*

## FIELD WIRING

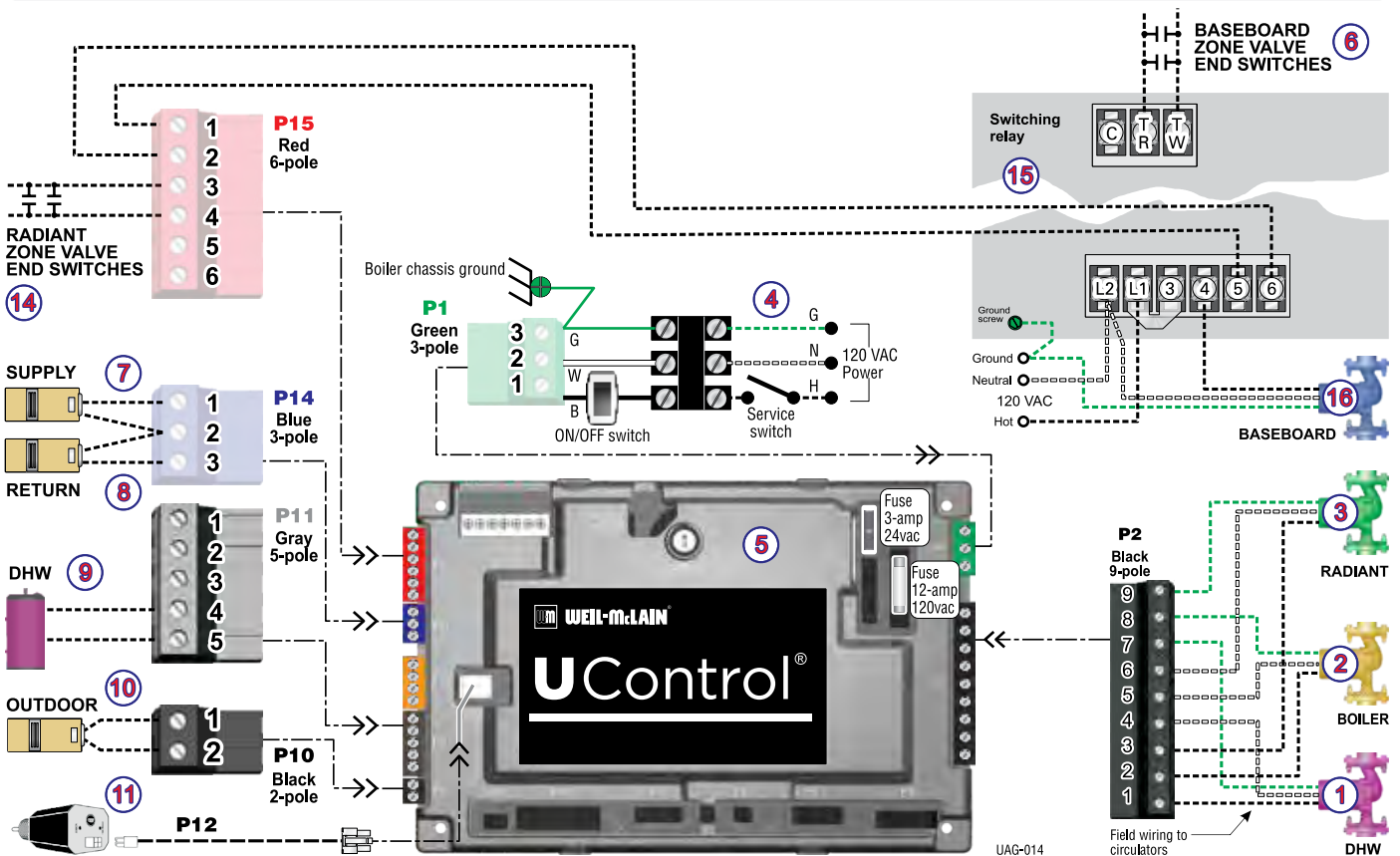



# Application 15

Single-zone BASEBOARD | Single-zone RADIANT | POOL Heat exchanger  
(Radiant load must be <30% of total heat loss)

## Purpose

- Single zone of radiant, single zone of baseboard (finned tube or cast iron) and single zone for pool heat exchanger. This application can be adapted for multiple zones if piping components and controls are added to control the zone circulators or zone valves and provide a call for heat signal to the U-Control.
- Zoning with circulators.

## U-Control setting notes

- System type DHW SYSTEM is used for BOILER PRIORITY 3, the WMPH zone. This prevents outdoor reset regulation of the supply water temperature to the pool heater.

## Circulators and piping

- Piping must be primary/secondary as shown.

### BASEBOARD

- Single zone. Multiple zones can be used if zone controller and piping components are added.
- Size circulators for required flow.
- Baseboard circulators supplied by installer.

### RADIANT

- Single zone. Multiple zones can be used if zone controller and piping components are added.

**NOTICE**

See **Application 7a**, page 22, for radiant heating using independent temperature control for the radiant zone, with no limit to the radiant load.

- Size circulators for required flow. Radiant circulators supplied by installer.

### HEAT EXCHANGER

- Size circulator for required flow.
- Typical application shown using Weil-McLain pool heat exchanger (WMBP).
- Heat exchanger and circulator supplied by installer.

### BOILER

- See boiler manual for sizing.
- Circulator shipped loose with boiler.
- Boiler loop piping can be provided using optional Easy-Up Manifolds, available from Weil-McLain (see page 5).

## Wiring

- Connect field wiring as shown on next page.
- For circulators connected to the U-Control, the maximum circulator load is 2.2 amps each — if load is higher, provide a circulator relay or contactor for circulator power.
- Provide a relay to operate boiler circulator.

<b>U-CONTROL SETTINGS</b>		XXX	— VALUE MUST BE SET (OR VERIFIED) AS INDICATED
(SEE NAVIGATION FLOW BELOW)		D	— DEFAULT ACCEPTABLE; CHANGE ONLY IF DESIRED
<b>BOILER SETTINGS</b>			
BOILER MODEL		Verify model number is correct	
HIGH ALTITUDE		Set to YES if high altitude	
HIGH LIMIT		D	
WWSD TEMP		DEFAULT (70 °F) OR AS REQUIRED	
ADJUST OUTDOOR		DEFAULT (0 °F) OR AS REQUIRED	
ADD'L HEAT DEMAND TYPE		Type 1	
ADD'L HEAT DEMAND TIME		DEFAULT (0 minutes)	
<b>SYSTEM SETTINGS</b>			
<b>BOILER PRIORITY 1</b> <b>Baseboard</b> (Finned tube or cast iron)	SYSTEM TYPE	Select from list	FTB or CIB
	TEMPERATURES	Max Supply	180 F
		Min Supply	D
		Max OD Reset	D (70F) or as req'd
		Min OD Reset	D (0F) or as req'd
		Modulate On Diff	D
		Modulate Off Diff	D
	TIMES	Max On Time	D
		Boost Interval	D
		Prepump Time: Postpump Time:	D D
CIRCULATORS	Circulator 1 Circulator 2 Circulator 3	ON ON OFF	
MAXIMUM RATE		D	
MINIMUM RATE		D	
<b>BOILER PRIORITY 2</b> <b>Radiant zone</b>	SYSTEM TYPE	Select from list	Note 1 (at left)
	TEMPERATURES	Max Supply	As required
		Min Supply	D
		Max OD Reset	D (70F) or as req'd
		Min OD Reset	D (0F) or as req'd
		Modulate On Diff	D
		Modulate Off Diff	D
	TIMES	Max On Time	D
		Min On Time	D
		Boost Interval	D
Prepump Time: Postpump Time:		D D	
CIRCULATORS	Circulator 1 Circulator 2 Circulator 3	OFF ON OFF	
MAXIMUM RATE		D	
MINIMUM RATE		D	
<b>BOILER PRIORITY 3</b> <b>WMPH zone</b>	SYSTEM TYPE	Select from list	DHW SYSTEM
	TEMPERATURES	Max Supply	190 F
		Min Supply	D
		Max OD Reset	D
		Min OD Reset	D
		Modulate On Diff	D
		Modulate Off Diff	D
	TIMES	Min On Time	D
		Boost Interval	D
		Prepump Time: Postpump Time:	D D
CIRCULATORS		Circulator 1 Circulator 2 Circulator 3	OFF ON ON
MAXIMUM RATE		D	
MINIMUM RATE		D	
CIRCULATOR EXERCISING	Circulator 1 Circulator 2 Circulator 3	D D D	
FREEZE PROTECT CIRC'S	Circulator 1 Circulator 2 Circulator 3	D D D	



## PIPING

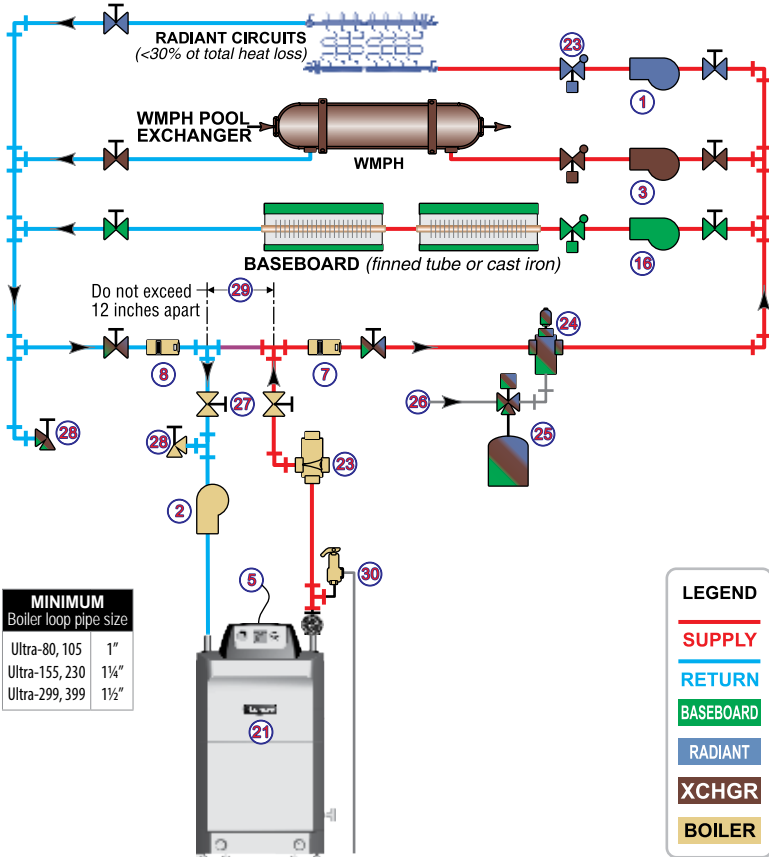

## LEGEND

\* = Supplied by installer

- 1 BASEBOARD circulator \*
- 2 BOILER circulator (shipped loose with boiler)
- 3 POOL HEAT EXCHANGER circulator \*
- 4 120VAC power supply, 15-amp minimum rating
- 5 U-Control
- 6 Baseboard zone thermostat \*
- 7 Supply temperature sensor — strap to supply line
- 8 Return temperature sensor — strap to return line
- 10 Outdoor temperature sensor (supplied with boiler; install if U-Control will be set for outdoor reset operation)
- 11 Low water cutoff (if used) \*
- 14 Radiant zone thermostat \*
- 15 2-pole relay \*
- 16 RADIANT circulator \*
- 18 Pool heater aquastat \*
- 21 Ultra boiler
- 23 Flow/check valves \*
- 24 Air separator with automatic air vent \*
- 25 Diaphragm-type expansion tank \*
- 26 Fresh water supply — install per applicable codes \*
- 27 Isolation valves \*
- 28 Purge/drain valves \*
- 29 Secondary piping connection for boiler loop \*
- 30 Boiler relief valve (install per boiler manual)

## FIELD WIRING

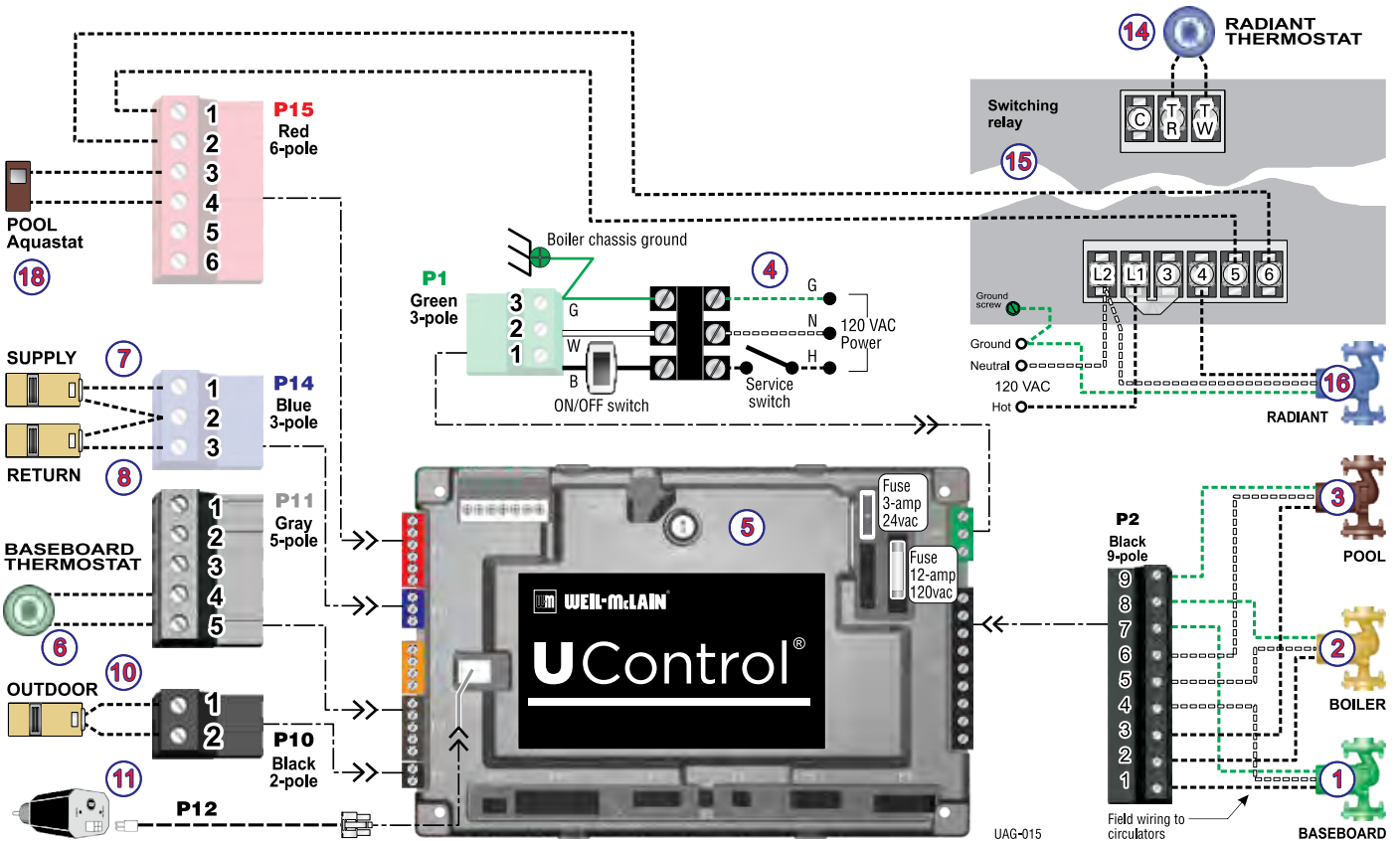



# Application 16

Single or Multi-zone **SPACE HEATING** | DHW (Direct-connected) | ISOLATION Heat exchanger (Tall buildings)  
 (Use where space heating system operating pressure is over 25 PSIG)

## Purpose

- Isolation heat exchanger for applications with high system pressure (over 25 PSIG), such as tall buildings. Typical application shown using Weil-McLain WMBP brazed-plate exchanger.
- Space heating via hot water feed to building terminal units.
- Space heating circulator and heat exchanger primary circulator are activated on call for heat by the heating system.
- DHW piped directly to the boiler.
- DHW priority — space heating and heater exchanger heating are disabled during call for heat from water heater.

## U-Control setting notes

- See the table at right for required and optional settings.
- To see the navigation sequence to access the BOILER SETTINGS and SYSTEM SETTINGS menus, see page 7.
- Select DHW DIRECT for the DHW BOILER PRIORITY 1. This informs the control that the DHW tank is directly connected to the boiler.

## Circulators and piping

- Piping must be primary/secondary as shown.

### DHW

- DHW circulator must be selected to handle the pressure drop through the Ultra boiler, water heater and piping — see boiler manual for recommended sizing. DHW circulator supplied by installer.
- For some large indirect water heaters, the required flow rate may require piping the water heater differently — see boiler manual and other applications in this guide.
- U-Control is set for DHW priority — space heating will be discontinued during a call for DHW.

### HEAT EXCHANGER

- Size circulator for required flow and pressure drop.
- Heat exchanger, piping components and circulator supplied by installer (except the boiler circulator, shipped loose with the boiler).

### SPACE HEATING

- Size circulator for required flow and pressure drop.
- Terminal units, piping components and circulator supplied by installer.

### BOILER

- See boiler manual for sizing.
- Circulator shipped loose with boiler.
- Boiler loop piping can be provided using optional Easy-Up Manifolds, available from Weil-McLain (see page 5).

## Wiring

- Connect field wiring as shown on next page.
- Provide a relay to operate space heating circulator.
- For circulators connected to the U-Control, the maximum circulator load is 2.2 amps each — if load is higher, provide a circulator relay or contactor for circulator power.
- DO NOT connect the outdoor sensor to the U-Control unless the water supply to the heat exchanger is to be reset based on outdoor temperature.

<b>U-CONTROL SETTINGS</b>				
(SEE NAVIGATION FLOW BELOW)		<b>XXX</b>	— VALUE MUST BE SET (OR VERIFIED) AS INDICATED	
		<b>D</b>	— DEFAULT ACCEPTABLE; CHANGE ONLY IF DESIRED	
<b>BOILER SETTINGS</b>				
BOILER MODEL	Verify model number is correct			
HIGH ALTITUDE	Set to YES if high altitude			
HIGH LIMIT	D			
WWSD TEMP	DEFAULT (70 °F) OR AS REQUIRED			
ADJUST OUTDOOR	DEFAULT (0 °F) OR AS REQUIRED			
ADD'L HEAT DEMAND TYPE	D			
ADD'L HEAT DEMAND TIME	D			
<b>SYSTEM SETTINGS</b>				
<b>BOILER PRIORITY 1 DHW</b>	SYSTEM TYPE	Select from list	DHW Direct	
	TEMPERATURES	Max Supply	190 F	
		Max OD Reset	D	
		Min OD Reset	D	
		Modulate On Diff	D	
		Modulate Off Diff	D	
	TIMES	Max On Time	D	
		Boost Interval	D	
		Prepump Time: Postpump Time:	D D	
	CIRCULATORS	Circulator 1 Circulator 2 Circulator 3	ON OFF OFF	
MAXIMUM RATE		D		
MINIMUM RATE		D		
<b>BOILER PRIORITY 2 Heat exchanger</b>	SYSTEM TYPE	Select from list	CUS	
	TEMPERATURES	Max Supply	190 F	
		Min Supply	190 F	
		Max OD Reset	D	
		Min OD Reset	D	
		Modulate On Diff	D	
	TIMES	Max On Time	D	
		Min On Time	D	
		Boost Interval	D	
		Prepump Time: Postpump Time:	D D	
CIRCULATORS	Circulator 1 Circulator 2 Circulator 3	OFF ON ON		
MAXIMUM RATE		D		
MINIMUM RATE		D		
<b>BOILER PRIORITY 3 Not used</b>	SYSTEM TYPE	Select from list	D	
	TEMPERATURES	Max Supply	D	
		Min Supply	D	
		Max OD Reset	D	
		Min OD Reset	D	
		Modulate On Diff	D	
	TIMES	Min On Time	D	
		Boost Interval	D	
		Prepump Time: Postpump Time:	D D	
	CIRCULATORS	Circulator 1 Circulator 2 Circulator 3	D D D	
MAXIMUM RATE		D		
MINIMUM RATE		D		
<b>CIRCULATOR EXERCISING</b>	Circulator 1 Circulator 2 Circulator 3		D D D	
	<b>FREEZE PROTECT CIRC'S</b>	Circulator 1 Circulator 2 Circulator 3		D D D





## PIPING

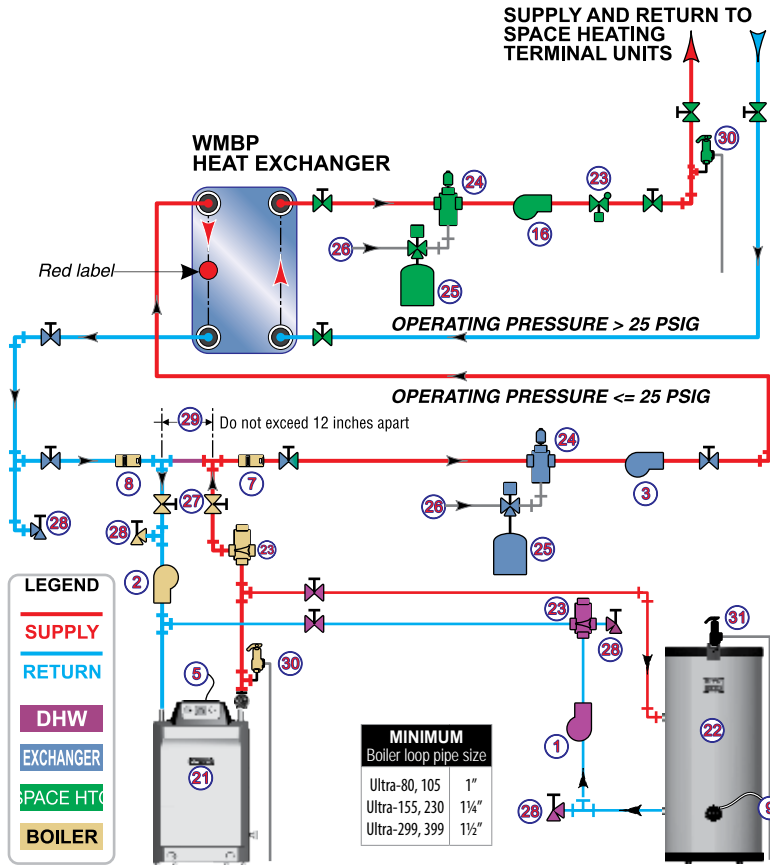

## LEGEND

\* = Supplied by installer

- DHW circulator \*
- BOILER circulator (shipped loose with boiler)
- HEAT EXCHANGER PRIMARY circulator \*
- 120VAC power supply, 15-amp minimum rating
- U-Control
- Supply temperature sensor — strap to supply line
- Return temperature sensor — strap to return line
- DHW tank aquastat or sensor\*
- Outdoor temperature sensor (supplied with boiler; install if U-Control will be set for outdoor reset operation)
- Low water cutoff (if used) \*
- Space heating thermostat or call for heat contact \*
- 2-pole relay \*
- SPACE HEATING circulator \*
- Ultra boiler
- Indirect water heater \*
- Flow/check valves \*
- Air separator with automatic air vent \*
- Diaphragm-type expansion tank \*
- Fresh water supply — install per applicable codes \*
- Isolation valves \*
- Purge/drain valves \*
- Secondary piping connection for boiler loop \*
- Relief valves — boiler (install per boiler manual) and heat exchanger space heating side
- DHW Temperature and Pressure relief valve (install per boiler manual)

## FIELD WIRING

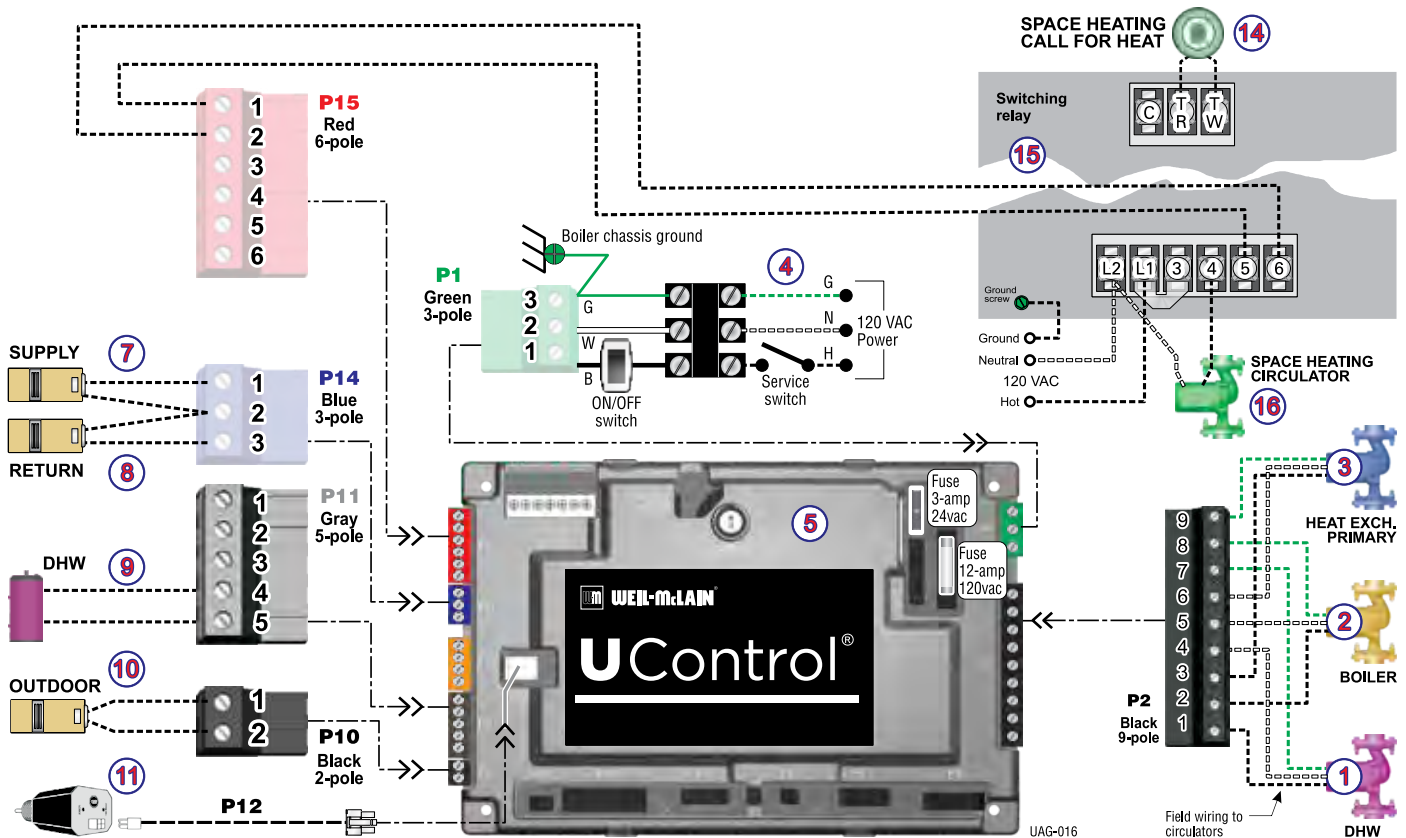



# Multiple boiler operation options

## Using the U-Control settings

### ADDITIONAL HEAT DEMAND

BOILER SETTINGS	
BOILER MODEL	
HIGH ALTITUDE	
HIGH LIMIT	
WWSD TEMP	
ADJUST OUTDOOR	
ADD'L HEAT DEMAND TYPE	
ADD'L HEAT DEMAND TIME	

- The ADD'L HEAT DEMAND settings (the two red boxes above) are for multiple boilers or multiple heating sources (an Ultra boiler collaborating with a heat pump or a different boiler, for examples).

**NOTICE** Additional heat demand **DOES NOT PASS ON** if the system type is DHW Direct or Custom. Do not use this setting on any boiler unless it is the last in the lead/shadow sequence.

### ADDITIONAL HEAT DEMAND settings

#### OFF

- Function disabled — NO signal would be passed on to other boilers.

#### Type 1

- This means the Ultra boiler is the primary heat source.
  - When the Ultra boiler receives a call for heat, it begins its startup sequence and also starts a delay timer (set as ADD'L HEAT DEMAND TIME).
  - When the ADD'L HEAT DEMAND TIME has elapsed, the U-Control closes the "Additional heat demand contact," terminals P16-6 & 7.
  - Use P16-6 & 7 to start the next heat source.
  - If the next heat source is an Ultra boiler, connect from the first boiler's P16-6 & 7 terminals to the second boiler's "Heat demand 1" terminals (P11-4 and 5).
  - Program the second boiler's ADD'L HEAT DEMAND TIME to start a third boiler the same way, and so on to sequentially fire multiple boilers.

#### Type 2

- This means the boiler is the secondary heat source.
  - When the U-Control receives a call for heat, it immediately activates the "Additional heat demand contact," terminals P16-6 & 7. This contact is used to start the next heat source immediately.
  - When the ADD'L HEAT DEMAND TIME has elapsed, the Ultra boiler begins its startup sequence and continues to heat until the demand is satisfied.
  - Type 2 assignment would generally only be used if the other heat source is a different boiler or a heat pump, for example.

#### Type 3

- This assigns the boiler as the LEAD boiler in a multiple boiler system.
  - The LEAD boiler must have system supply and return sensors mounted on the system supply and return pipes and wired to the boiler. An outdoor sensor must also be installed if outdoor reset is desired.
  - When the U-Control receives a call for heat, it begins its heating sequence and starts the ADD'L HEAT DEMAND TIME delay timer.
  - When the ADD'L HEAT DEMAND TIME has elapsed, the U-Control sends a 0-10 VDC proportional signal out its 0-10 VDC output terminals, P16-1 & 2.
  - Additional Ultra boilers are called SHADOW boilers.
  - Connect the LEAD boiler output terminals (P16-1 & 2) to the first SHADOW boiler's 0-10 VDC input terminals, P15-5 & 6.
  - For the LEAD boiler and all additional boilers except the last SHADOW boiler, connect P16-1 & 2 of each boiler to P15-5 & 6 of the next boiler.
  - Each SHADOW boiler will start and modulate based on the 0-10 VDC signal from the previous boiler.
  - The SHADOW boilers must be set up as Type 4 (see below). They do not need their ADD'L HEAT DEMAND TIME values to be set.

#### Type 4

- This assigns the boiler as a SHADOW boiler in a multiple boiler system.
  - For Type 4 boilers, the ADDITIONAL HEAT DEMAND function only applies to the Priority 1 system.
  - Wire the boilers as explained under Type 3, above.
  - Each SHADOW boiler must have system supply and return sensors mounted on the system supply and return pipes and wired to the boiler. An outdoor sensor must also be installed if outdoor reset is desired.



## Multiple boiler operation options (continued)

### Using the U-Control settings

#### SENSORS

1. Each Ultra boiler is shipped with three remote-mounted sensors — supply, return and outdoor. Supply and return sensors are strap-on type.
  - a. **Supply sensor** — Every boiler must have its supply sensor attached to the system supply piping. It must sense the temperature of the water going to the system. (The boiler has an integral sensor that monitors boiler outlet water temperature.) the LEAD boiler adjusts firing rate as needed to maintain system supply temperature. Shadow boilers modulate according to the 0–10 VDC signal from the lead boiler, but they turn on and off based on system supply temperature.
  - b. **Return sensor** — Every boiler must have its supply sensor attached to the system return piping to allow the boiler to monitor temperature rise through the boiler.
  - c. **Outdoor sensor** — Install an outdoor sensor for each boiler if the multiple boiler system will use outdoor reset.

**NOTICE**

The description of each multiple boiler application in this guide indicates which sensors are required to accomplish the intent of the application.

**THE OUTDOOR SENSOR SUPPLIED WITH THE BOILER MUST BE INSTALLED UNLESS EXEMPTED BELOW:**

**IMPORTANT**

In accordance with **Section 303 of the 2007 Energy Act**, this boiler is equipped with a feature that saves energy by reducing the boiler water temperature as the heating load decreases. This feature is equipped with an override which is provided primarily to permit the use of an external energy management system that serves the same function.

**THIS OVERRIDE MUST NOT BE USED UNLESS AT LEAST ONE OF THE FOLLOWING CONDITIONS IS TRUE:**

- An external energy management system is installed that reduces the boiler water temperature as the heating load decreases.
- This boiler is not used for any space heating.
- This boiler is part of a modular or multiple boiler system having a total input of 300,000 BTU/hr or greater.
- This boiler is equipped with a tankless coil (not applicable to Ultra boilers).

#### ADDITIONAL HEAT DEMAND applications

##### Type 1 and Type 2 applications

1. **Application 17a — Multiple heat sources** applies this option to delay operation of the Ultra boiler, allowing time for the primary heat source to satisfy the call for heat from the thermostat, end switches, etc.
  - a. The Ultra boiler is setup as Type 2.
  - b. When the room thermostat calls for heat at the Ultra boiler, the U-Control immediately closes the contact across P16 terminals 6 and 7.
  - c. This contact is used to start the auxiliary heat source (wood stove, etc.)
  - d. The U-Control also immediately starts its ADD'L HEAT DEMAND TIME timer (set at 60 minutes for this application). If this timer elapses and the call for heat is still present, the Ultra boiler will fire.
  - e. The Ultra boiler will operate the boiler circulator and system circulator to provide heat to the baseboard units.
  - f. This application provides DHW using the Priority 2 functions of the Ultra boiler. With the Priority 1 MAX ON TIME set to 0, the Ultra boiler will immediately switch to DHW operation on any call from the DHW tank.
2. Other possible applications of Type 1/Type 2 —
  - a. **Application 17 — Multiple heat sources** could be setup with the Ultra boiler specified as Type 2, with ADD'L HEAT DEMAND TIME set to 60 minutes, typically. The aquastat (item 14) near the heat exchanger outlet would not be used in this case. This setup would provide 60 minutes for the auxiliary heat

source to satisfy demand before the Ultra boiler would fire for space heating. The Ultra boiler will always respond to a call for heat from the DHW tank.

- b. **Combustion air heater** — An Ultra boiler could be set as Type 2, with terminals P16–1 & 2 used to start a combustion air heater. Set the time delay to 10 minutes to allow time for combustion air heater to reach steady-state operation before the Ultra boiler fires.

##### Type 3 and Type 4 — Sequential operation

1. Sequential operation is achieved by setting a time delay between boiler start-ups. This method is used in:
  - a. **Application 18 — Multiple boilers**
  - b. **Application 19 — Multiple boilers**
  - c. **Application 20 — Multiple boilers**
  - d. **Application 21 — Multiple boilers.**
2. Use the ADD'L HEAT DEMAND TIME setting to delay activation of each successive boiler in a multiple boiler system.
  - a. When one of the boilers receives a call for heat, the U-Control starts the ADD'L HEAT DEMAND TIME timer. Only when this timer elapses is the signal to start passed on to the next boiler — that is, after this time elapses, the U-Control sends a 0–10 VDC signal out of P16 terminals 1 and 2.
  - b. Typically, set the ADD'L HEAT DEMAND TIME to 5 minutes for all boilers except the last shadow boiler.
  - c. Wire each boiler with its P16-1 & 2 output terminals (0–10 VDC) going to the P15-5 & 6 terminals of the next boiler.
3. Staging of boilers can also be improved by the setting of each boiler's MODULATE ON and MODULATE OFF differentials, as explained below.
4. Set the SHADOW boilers' MODULATE ON DIFF and MODULATE OFF DIFF settings at different values to cause the SHADOW boilers to cycle at different system SUPPLY temperatures. This will improve the sequential firing of SHADOW boilers.
  - The applications in this guide use ON/OFF values of 5°F/10°F for the first SHADOW boiler and 10°F/5°F for the last SHADOW boiler.
  - For systems with more than three boilers, these values can be graduated to improve sequencing. Example: for four boilers, use MODULATE ON DIFF values of 3/6/9 and OFF DIFF values of 9/3/6.

**NOTICE**

To effectively use outdoor reset, all SHADOW boilers must have OUTDOOR sensors installed if the LEAD boiler is set up for outdoor reset operation. The MAX SUPPLY, MIN SUPPLY, MAX OD RESET and MIN OD RESET values must be set exactly as on the LEAD boiler.

DO NOT use outdoor sensors and outdoor reset on multiple boilers supplying a system that requires fixed high-temperature water, such as DHW applications with the water heaters piped in the system, not directly to one of the boilers.

**NOTICE**

The modulating signal from U-Control P16 of one boiler to P15 of the next is polarity sensitive. Connect wires + to + and – to – as shown. That is, P16–1 goes to P15–6 and P16–2 goes to P15–5.



# Application 17 — Multiple heat sources

ALTERNATIVE **HEAT SOURCE** as *primary* / ULTRA as *back-up* | Single-zone BASEBOARD or FAN COIL  
DHW (Direct-connected)

## Purpose

- The main heat source for this system is a wood-fired boiler or other alternative heat source. The Ultra boiler provides back-up heating. In addition, the Ultra boiler provides domestic hot water via an indirect water heater.
- Space heating is with baseboard, fan coils or other. This application can be adapted for multiple zones if piping components and controls are added to control the zone circulators or zone valves and provide a call for heat signal to the U-Control.
- DHW piped directly to the Ultra boiler.
- DHW priority — space heating is disabled for the Ultra boiler during call for heat from the water heater.

## Circulators and piping

- Piping must be primary/secondary as shown.

### DHW

- DHW circulator must be selected to handle the pressure drop through the Ultra boiler, water heater and piping — see boiler manual for recommended sizing. DHW circulator supplied by installer.
- For some large indirect water heaters, the required flow rate may require piping the water heater differently — see boiler manual and other applications in this guide.
- U-Control is set for DHW priority — space heating will be discontinued during a call for DHW.

### BASEBOARD

- Size circulator for required flow. The circulator must be selected to handle the head loss through the heat exchanger in addition to the system heat losses.

### ALTERNATIVE HEAT SOURCE

- Provide a heat source (such as a wood-fired boiler, solar heat system, etc.) with all controls and piping (per manufacturer's instructions). A circulator must be supplied in the heat source piping.
- HEAT SOURCE, associated piping and components, and all circulators (except the boiler circulator) supplied by installer.
- Select a heat exchanger for the required load. Use a shell and tube exchanger as shown in the piping diagram. A brazed-plate exchanger can be used, but only if the HEAT SOURCE system is closed.
- If more suited to the application, swap the shell side and tube side of the exchanger versus the piping diagram.

### ULTRA BOILER

- See boiler manual for sizing.
- Circulator shipped loose with boiler.
- Boiler loop piping can be provided using optional Easy-Up Manifolds, available from Weil-McLain (see page 5).

## Wiring

- Connect field wiring as shown on next page.
- Provide a circulator zone controller to operate the baseboard system circulator and provide call for heat to alternative heat source and the Ultra boiler.
- For circulators connected to the U-Control, the maximum circulator load is 2.2 amps each — if load is higher, provide a circulator relay or contactor for circulator power.
- Provide and install an aquastat in the supply line from the heat exchanger as shown. This aquastat will activate the Ultra boiler if the supply water temperature falls below the aquastat setting.

<b>U-CONTROL SETTINGS</b>			
(SEE NAVIGATION FLOW BELOW)		<b>XXX</b> — VALUE MUST BE SET (OR VERIFIED) AS INDICATED	<b>D</b> — DEFAULT ACCEPTABLE; CHANGE ONLY IF DESIRED
<b>BOILER SETTINGS</b>			
BOILER MODEL		<b>Verify model number is correct</b>	
HIGH ALTITUDE		<b>Set to YES if high altitude</b>	
HIGH LIMIT		D	
WWS D TEMP		<b>DEFAULT (70 °F) OR AS REQUIRED</b>	
ADJUST OUTDOOR		<b>DEFAULT (0 °F) OR AS REQUIRED</b>	
ADD'L HEAT DEMAND TYPE		D	
ADD'L HEAT DEMAND TIME		D	
<b>SYSTEM SETTINGS</b>			
<b>BOILER PRIORITY 1 DHW</b>	SYSTEM TYPE	Select from list	<b>DHW Direct</b>
	TEMPERATURES	Max Supply	<b>190 F</b>
		Max OD Reset	D
		Min OD Reset	D
		Modulate On Diff	D
	TIMES	Modulate Off Diff	D
		Max On Time	D
		Boost Interval	D
	CIRCULATORS	Prepump Time:	D
		Postpump Time:	D
Circulator 1		<b>ON</b>	
MAXIMUM RATE	Circulator 2	<b>OFF</b>	
	Circulator 3	<b>OFF</b>	
MINIMUM RATE		D	
<b>BOILER PRIORITY 2 Baseboard (Finned tube or cast iron)</b>	SYSTEM TYPE	Select from list	<b>FTB or FCL</b>
	TEMPERATURES	Max Supply	<b>180 F</b>
		Min Supply	D
		Max OD Reset	<b>D (70F) or as req'd</b>
		Min OD Reset	<b>D (0F) or as req'd</b>
	TIMES	Modulate On Diff	D
		Modulate Off Diff	D
		Max On Time	D
	CIRCULATORS	Min On Time	D
		Boost Interval	D
Prepump Time:		D	
MAXIMUM RATE	Postpump Time:	D	
	Circulator 1	<b>OFF</b>	
MINIMUM RATE	Circulator 2	<b>ON</b>	
<b>BOILER PRIORITY 3 Not used</b>	TEMPERATURES	Circulator 3	<b>OFF</b>
		Max Supply	D
		Min Supply	D
		Max OD Reset	D
	TIMES	Min OD Reset	D
		Modulate On Diff	D
		Modulate Off Diff	D
	CIRCULATORS	Min On Time	D
		Boost Interval	D
		Prepump Time:	D
MAXIMUM RATE	Postpump Time:	D	
	Circulator 1	D	
MINIMUM RATE	Circulator 2	D	
<b>CIRCULATOR EXERCISING</b>	Circulator 3	D	
	Circulator 1	D	
	Circulator 2	D	
<b>FREEZE PROTECT CIRC'S</b>	Circulator 3	D	
	Circulator 1	D	
	Circulator 2	D	



## PIPING

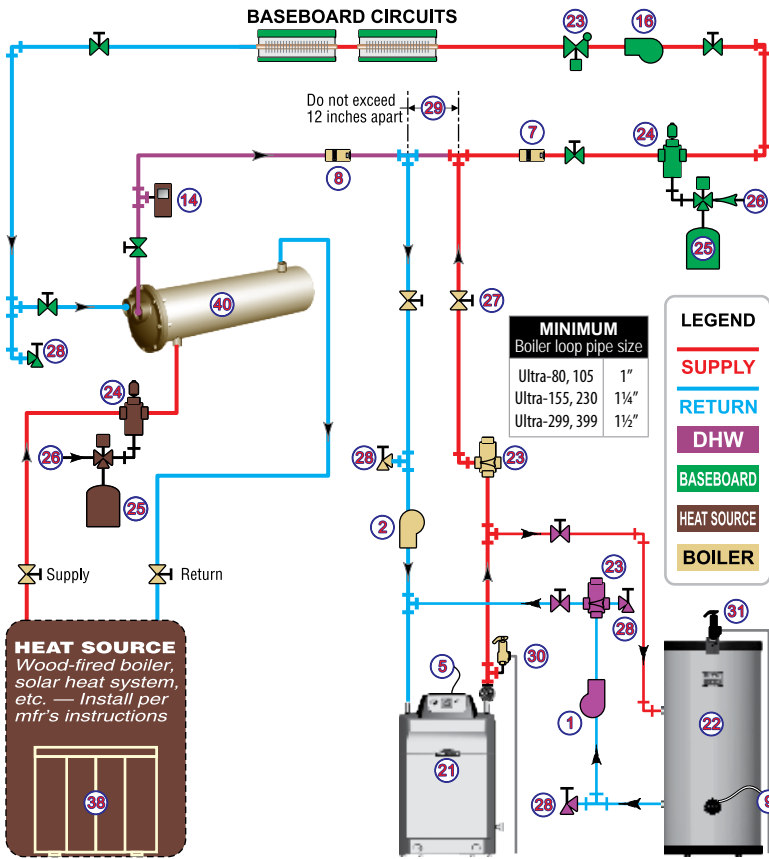

## LEGEND

\* = Supplied by installer

- DHW circulator \*
- BOILER circulator (shipped loose with boiler)
- 120VAC power supply, 15-amp minimum rating
- U-Control
- Baseboard (or fan coil) thermostat \*
- Supply temperature sensor — strap to supply line
- Return temperature sensor — strap to return line
- DHW tank aquastat or sensor\*
- Outdoor temperature sensor (supplied with boiler; install if U-Control will be set for warm weather shutdown)
- Low water cutoff (if used) \*
- Aquastat in supply line from HEAT SOURCE piping \*
- Circulator zone control \*
- System circulator \*
- Ultra boiler
- Indirect water heater \*
- Flow/check valves \*
- Air separator with automatic air vent \*
- Diaphragm-type expansion tank \*
- Fresh water supply — install per applicable codes \*
- Isolation valves \*
- Purge/drain valves \*
- Secondary piping connection for boiler loop \*
- Boiler relief valve (install per boiler manual)
- DHW Temperature and Pressure relief valve (install per boiler manual)
- Alternative heat source and piping per mfr's instructions \* (must include a circulator and all piping and components specified in manufacturer's instructions)
- Isolation heat exchanger (DO NOT use a brazed-plate exchanger when connected to an open system) \*

## FIELD WIRING

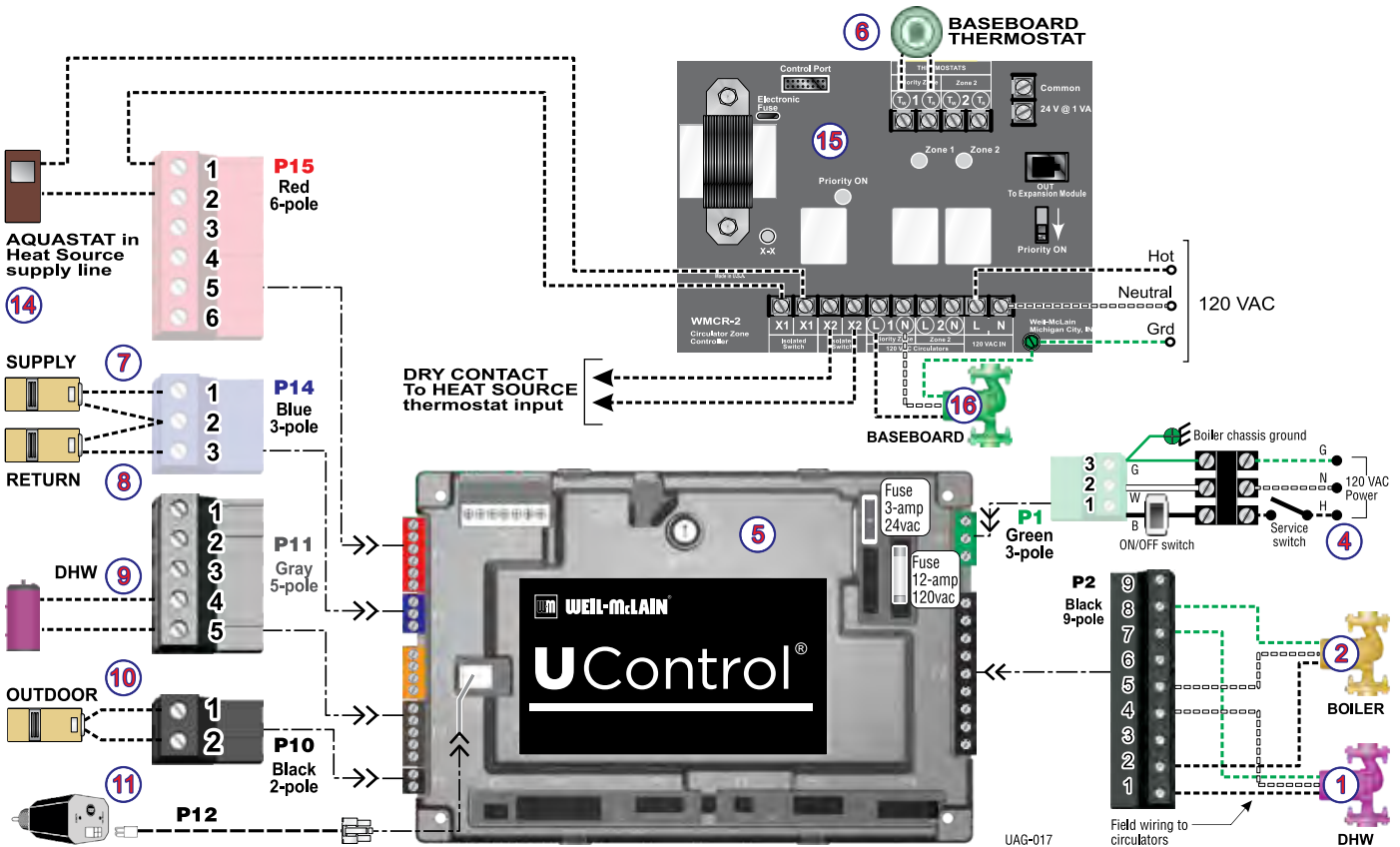



# Application 17a — Multiple heat sources

**NON-HYDRONIC PRIMARY HEAT SOURCE as Type 1 (LEAD) / ULTRA as Type 2 (BACKUP)**  
 Single-zone or multi-zone BASEBOARD or FAN COIL | DHW (Direct-connected)

## Purpose

- The main heat source for this system is a non-hydronic heating unit, such as a wood-fired stove or warm-air furnace. The Ultra boiler provides back-up heating. In addition, the Ultra boiler provides domestic hot water via an indirect water heater.
- Space heating is with baseboard, fan coils or other. This application can be adapted for multiple zones if piping components and controls are added to control the zone circulators or zone valves and provide a call for heat signal to the U-Control.
- DHW piped directly to the Ultra boiler.
- DHW priority — space heating is disabled for the Ultra boiler during call for heat from the water heater.

## Circulators and piping

- Piping must be primary/secondary as shown.

### DHW

- DHW circulator must be selected to handle the pressure drop through the Ultra boiler, water heater and piping — see boiler manual for recommended sizing. DHW circulator supplied by installer.
- For some large indirect water heaters, the required flow rate may require piping the water heater differently — see boiler manual and other applications in this guide.
- U-Control Priority 1 MAX ON TIME is set to 0 minutes. The control will immediately switch to DHW heating on call from the DHW aquastat.

### BASEBOARD

- Size circulator for required flow.
- The baseboard circulator must be supplied by the installer.

### ALTERNATIVE HEAT SOURCE

- Provide a heat source (such as a wood-fired stove) with all controls needed, per manufacturer's instructions.

### ULTRA BOILER

- See boiler manual for sizing.
- Circulator shipped loose with boiler.
- Boiler loop piping can be provided using optional Easy-Up Manifolds, available from Weil-McLain (see page 5).

## Wiring

- Connect field wiring as shown on next page.
- For circulators connected to the U-Control, the maximum circulator load is 2.2 amps each — if load is higher, provide a circulator relay or contactor for circulator power.
- Provide and install a room thermostat. The thermostat provides a call for heat to the Ultra boiler. The Ultra boiler is set as ADD'L HEAT DEMAND Type II — it will immediately pass the call for heat on to the alternative heat source. If the ADD'L HEAT DEMAND TIME elapses and the thermostat is still calling for heat, the Ultra boiler will come on and provide heat to the hydronic system.

### NOTICE

**Set the Ultra boiler Priority 1 MAX ON TIME to 0 minutes.** The boiler will immediately switch to DHW mode on call from the DHW aquastat.

<b>U-CONTROL SETTINGS</b>		xxx	— VALUE MUST BE SET (OR VERIFIED) AS INDICATED	
(SEE NAVIGATION FLOW BELOW)		D	— DEFAULT ACCEPTABLE; CHANGE ONLY IF DESIRED	
<b>BOILER SETTINGS</b>				
BOILER MODEL			Verify model number is correct	
HIGH ALTITUDE			Set to YES if high altitude	
HIGH LIMIT		D		
WWSD TEMP			DEFAULT (70 °F) OR AS REQUIRED	
ADJUST OUTDOOR			DEFAULT (0 °F) OR AS REQUIRED	
ADD'L HEAT DEMAND TYPE			Type 2 – BACKUP	
ADD'L HEAT DEMAND TIME			60 minutes	
<b>SYSTEM SETTINGS</b>				
<b>BOILER PRIORITY 1</b> Baseboard (Finned tube or cast iron)	SYSTEM TYPE	Select from list	FTB or FCL	
	TEMPERATURES	Max Supply		180 F
		Min Supply		D
		Max OD Reset		D (70F) or as req'd
		Min OD Reset		D (0F) or as req'd
		Modulate On Diff		D
	TIMES	Modulate Off Diff		D
		Max On Time		0 minutes
		Min On Time		D
		Boost Interval		D
CIRCULATORS	Prepump Time:		D	
	Postpump Time:		D	
	Circulator 1		OFF	
MAXIMUM RATE	Circulator 2		ON	
	Circulator 3		ON	
MINIMUM RATE			D	
<b>BOILER PRIORITY 2</b> DHW	SYSTEM TYPE	Select from list	DHW Direct	
	TEMPERATURES	Max Supply		190 F
		Max OD Reset		D
		Min OD Reset		D
		Modulate On Diff		D
		Modulate Off Diff		D
	TIMES	Max On Time		D
		Min On Time		60 minutes
		Boost Interval		D
		Prepump Time:		D
CIRCULATORS	Postpump Time:		D	
	Circulator 1		ON	
	Circulator 2		OFF	
MAXIMUM RATE	Circulator 3		OFF	
	MINIMUM RATE		D	
<b>BOILER PRIORITY 3</b> Not used	SYSTEM TYPE	Select from list	D	
	TEMPERATURES	Max Supply		D
		Min Supply		D
		Max OD Reset		D
		Min OD Reset		D
		Modulate On Diff		D
	TIMES	Modulate Off Diff		D
		Min On Time		D
		Boost Interval		D
		Prepump Time:		D
CIRCULATORS	Postpump Time:		D	
	Circulator 1		D	
	Circulator 2		D	
MAXIMUM RATE	Circulator 3		D	
	MINIMUM RATE		D	
<b>CIRCULATOR EXERCISING</b>	Circulator 1		D	
	Circulator 2		D	
	Circulator 3		D	
<b>FREEZE PROTECT CIRC'S</b>	Circulator 1		D	
	Circulator 2		D	
	Circulator 3		D	



## PIPING

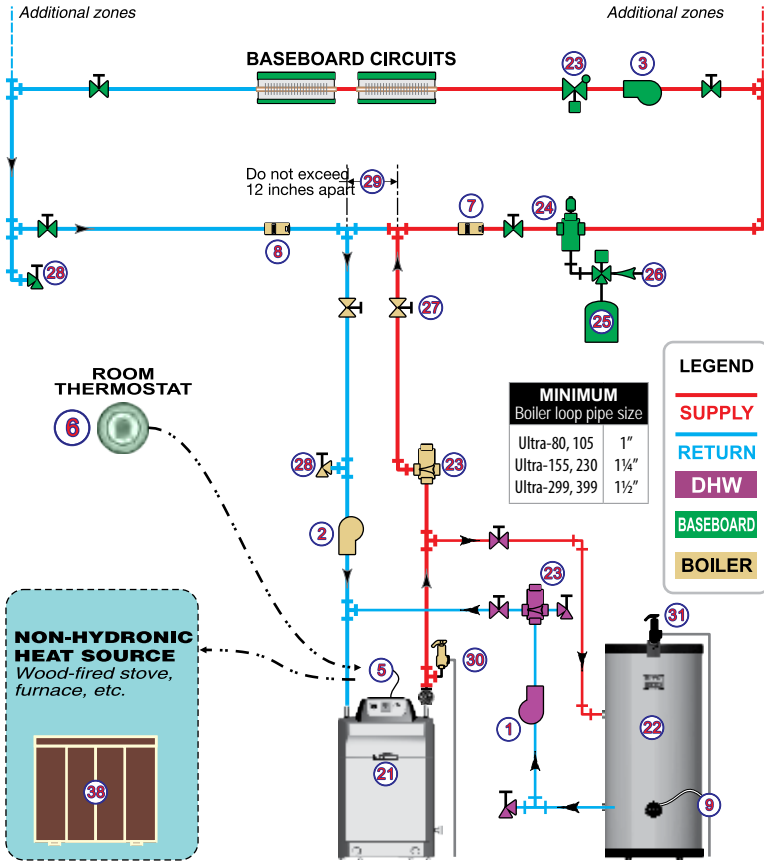

## LEGEND

\* = Supplied by installer

- DHW circulator \*
- BOILER circulator (shipped loose with boiler)
- System (or zone) circulator \*
- 120VAC power supply, 15-amp minimum rating
- U-Control
- Room thermostat \*
- Supply temperature sensor — strap to supply line
- Return temperature sensor — strap to return line
- DHW tank aquastat or sensor\*
- Outdoor temperature sensor (supplied with boiler; install if U-Control will be set for warm weather shutdown)
- Low water cutoff (if used) \*
- Ultra boiler
- Indirect water heater \*
- Flow/check valves \*
- Air separator with automatic air vent \*
- Diaphragm-type expansion tank \*
- Fresh water supply — install per applicable codes \*
- Isolation valves \*
- Purge/drain valves \*
- Secondary piping connection for boiler loop \*
- Boiler relief valve (install per boiler manual)
- DHW Temperature and Pressure relief valve (install per boiler manual)
- Alternative heat source, installed per mfr's instructions \*

## FIELD WIRING

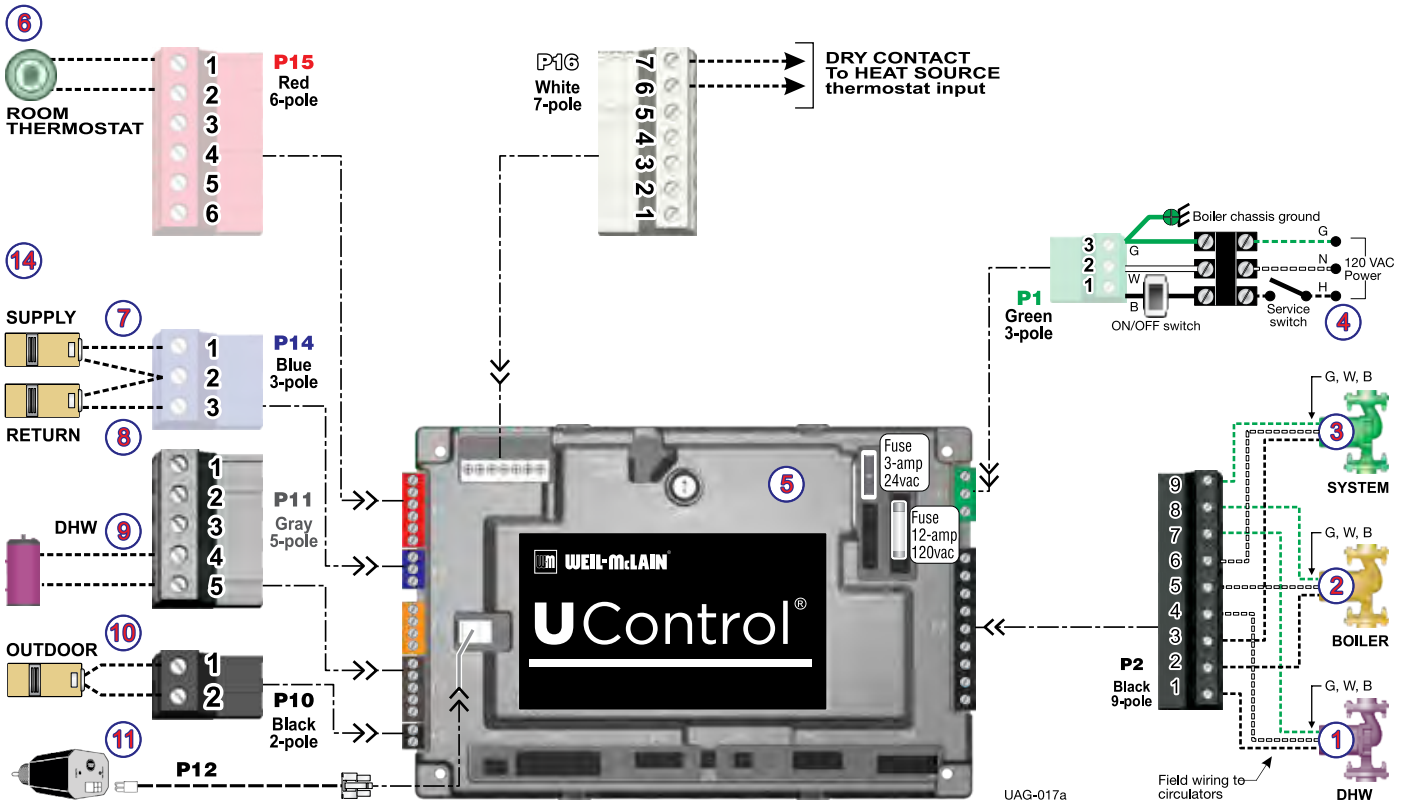



# Application 18 — Multiple boilers

Multiple Ultra boilers | Multiple-zone **SPACE HEATING** (Circulators with WMCR) | DHW (Direct-connected)

## Purpose

- Space heating with multiple Ultra boilers and multi-zone space heating using baseboard, fan coils, or other (zoning with circulators).
- DHW piped directly to one boiler.
- DHW priority — space heating and heater exchanger heating are disabled during call for heat from water heater.

## Circulators and piping

### DHW

- DHW circulator must be selected to handle the pressure drop through the Ultra boiler, water heater and piping — see boiler manual for recommended sizing. DHW circulator supplied by installer.
- For some large indirect water heaters, the required flow rate may require piping the water heater differently — see boiler manual and other applications in this guide.
- Pipe the indirect water heater to the last SHADOW boiler. The U-Control on the last SHADOW boiler is set to immediately switch to DHW heating on call from the DHW aquastat. Set system type to DHW-DIRECT.

### BASEBOARD or FAN COIL

- Multiple zones.
- Size circulators for required flow.
- Zoning circulators supplied by installer.

### BOILER

- Ultra boiler piping must be primary/secondary as shown, with the boiler piped in a secondary loop and the DHW piped to the last SHADOW boiler.
- See boiler manual for sizing.
- Circulator shipped loose with each boiler.

## Wiring

- Connect field wiring as shown on next page.
- This application applies only to multiple-zone space heating, using a zone controller.
- For circulators connected to the U-Control, the maximum circulator load is 2.2 amps each — if load is higher, provide a circulator relay or contactor for circulator power.
- Provide a circulator zone controller for zone circulators.
- Connect the DHW aquastat only to the last boiler in the series.

## LEAD Boiler U-Control settings

<b>xxx</b>	— VALUE MUST BE SET (OR VERIFIED) AS LISTED		See SHADOW boiler settings on pages 50 and 51	
<b>D</b>	— DEFAULT ACCEPTABLE; CHANGE ONLY IF DESIRED			
<b>BOILER SETTINGS</b>				
BOILER MODEL	Verify model number is correct			
HIGH ALTITUDE	Set to YES if high altitude			
HIGH LIMIT	D			
WWSD TEMP	DEFAULT (70 °F) OR AS REQUIRED			
ADJUST OUTDOOR	DEFAULT (0 °F) OR AS REQUIRED			
ADD'L HEAT DEMAND TYPE	Type 3 – LEAD			
ADD'L HEAT DEMAND TIME	5 minutes			
<b>SYSTEM SETTINGS</b>				
<b>BOILER PRIORITY 1</b>  <b>Space heating (any type)</b>	SYSTEM TYPE	Select from list	Select type used	
	TEMPERATURES	Max Supply		180 F or as req'd
		Min Supply		D (70F) OR AS
		Max OD Reset		D (0F) OR AS
		Min OD Reset		D OR AS REQUIRED
		Modulate On Diff		D
	TIMES	Max On Time		D
		Boost Interval		D
		Prepump Time: Postpump Time:		D
	CIRCULATORS	Circulator 1		OFF
		Circulator 2		ON
		Circulator 3		OFF
	MAXIMUM RATE			D
	MINIMUM RATE			D
	<b>BOILER PRIORITY 2</b>  <b>Not used</b>	SYSTEM TYPE	Select from list	D
TEMPERATURES		Max Supply		D
		Min Supply		D
		Max OD Reset		D
		Min OD Reset		D
		Modulate On Diff		D
TIMES		Min On Time		D
		Boost Interval		D
		Prepump Time: Postpump Time:		D
CIRCULATORS		Circulator 1		D
		Circulator 2		D
		Circulator 3		D
MAXIMUM RATE				D
MINIMUM RATE				D
<b>BOILER PRIORITY 3</b>  <b>Not used</b>		SYSTEM TYPE	Select from list	D
	TEMPERATURES	Max Supply		D
		Min Supply		D
		Max OD Reset		D
		Min OD Reset		D
		Modulate On Diff		D
	TIMES	Min On Time		D
		Boost Interval		D
		Prepump Time: Postpump Time:		D
	CIRCULATORS	Circulator 1		D
		Circulator 2		D
		Circulator 3		D
	MAXIMUM RATE			D
	MINIMUM RATE			D
	<b>CIRCULATOR EXERCISING</b>	Circulator 1		D
Circulator 2			D	
Circulator 3			D	
<b>FREEZE PROTECT CIRC</b>	Circulator 1		D	
	Circulator 2		D	
	Circulator 3		D	





## PIPING

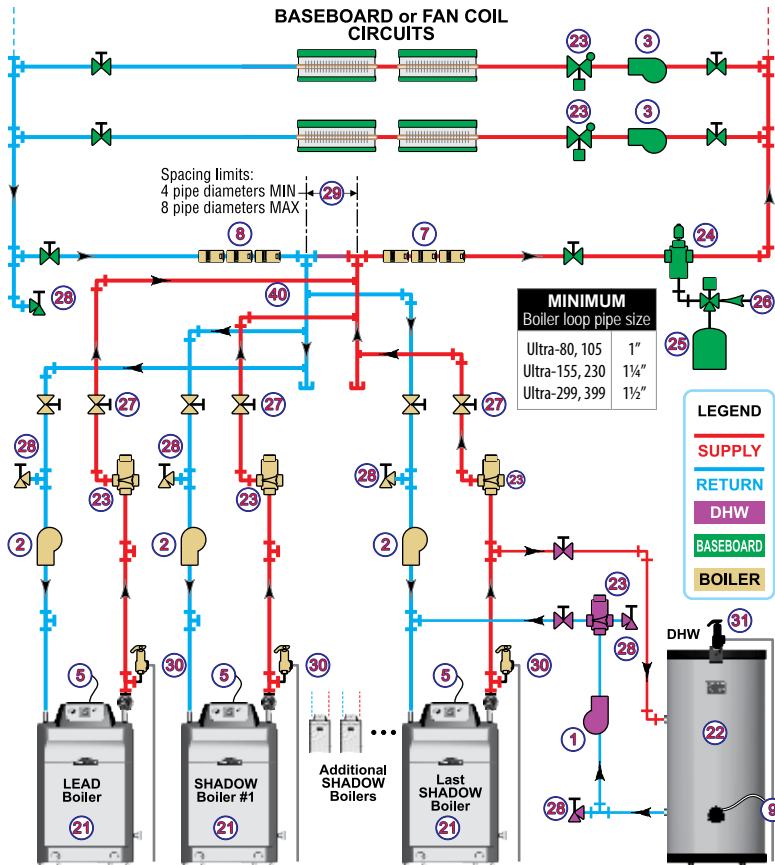

## LEGEND

\* = Supplied by installer

- DHW circulator \*
- BOILER circulator (shipped loose with boiler)
- Zone circulators \*
- 120VAC power supply, 15-amp minimum rating
- U-Control
- Zone thermostats \*
- Supply temperature sensor — strap to supply line
- Return temperature sensor — strap to return line
- DHW tank aquastat or sensor\*
- Outdoor temperature sensor (supplied with boiler; install if U-Control will be set for outdoor reset operation)
- Low water cutoff (if used) \*
- Circulator zone controller \*
- Ultra boiler
- Indirect water heater \*
- Flow/check valves \*
- Air separator with automatic air vent \*
- Diaphragm-type expansion tank \*
- Fresh water supply — install per applicable codes \*
- Isolation valves \*
- Purge/drain valves \*
- Secondary piping connection for boiler loop \*
- Boiler relief valve (install per boiler manual)
- DHW Temperature and Pressure relief valve (install per boiler manual)
- Manifolds, Weil-McLain Easy-Fit shown \*

## FIELD WIRING

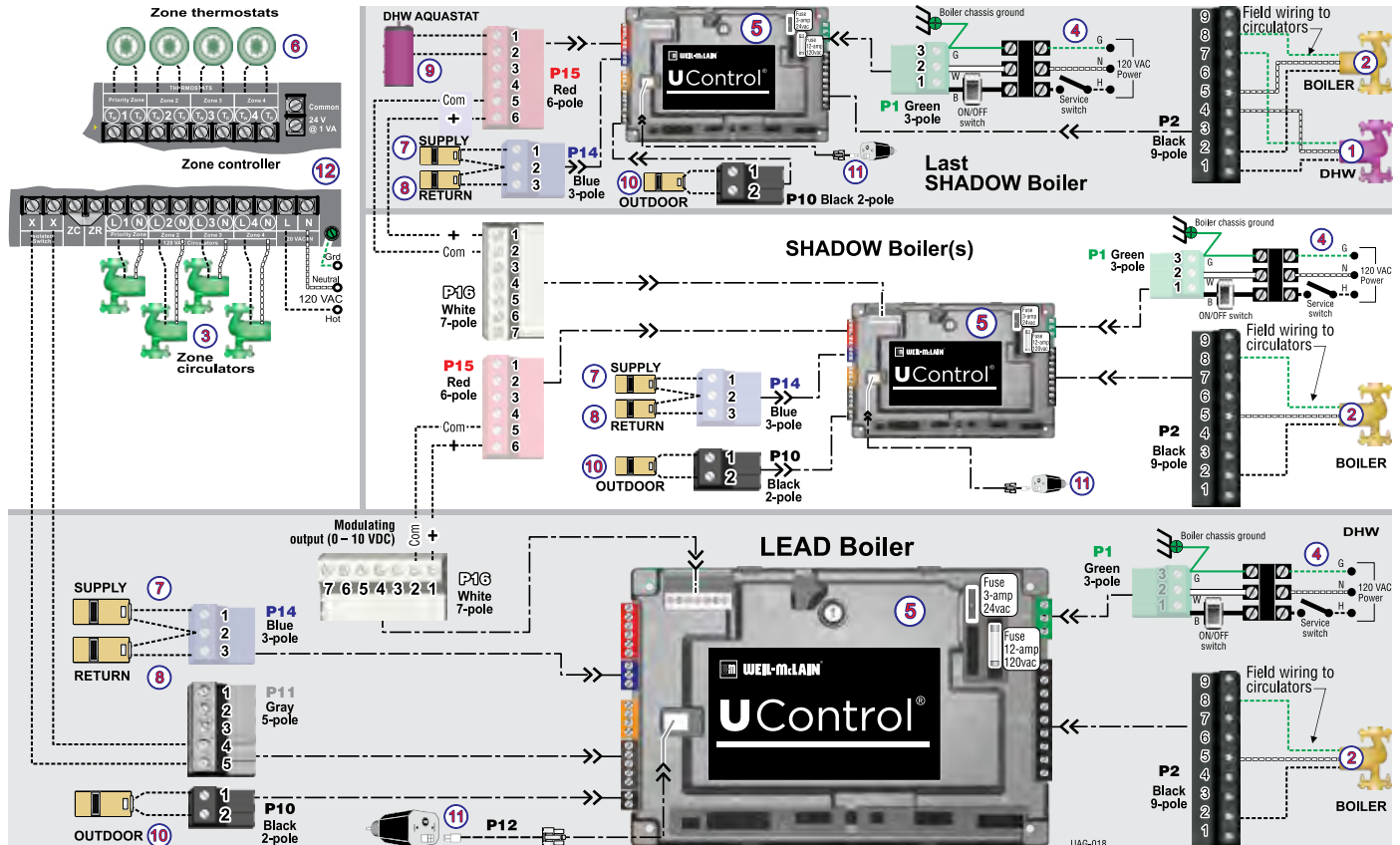



# Application 18 — Multiple boilers (continued)

Multiple Ultra boilers | Multiple-zone **SPACE HEATING** (Circulators with WMCR) | DHW (Direct-connected)

## U-Control setting notes (LEAD boiler)

- Additional heat time is set to 5 minutes to delay start of next boiler in sequence enough to allow system to respond. Change this setting value if desired.
- See following pages for addition boiler setting information.

**NOTICE** DO NOT set the LEAD boiler PRIORITY 1 SYSTEM TYPE to Custom or DHW. Shadow boilers set to TYPE 4 will not work with these settings.

**NOTICE** The modulating signal from U-Control P16 of one boiler to P15 of the next is polarity sensitive.

Connect wires + to + and - to - as shown. That is, P16-1 goes to P15-6 and P16-2 goes to P15-5.

## U-Control setting notes (SHADOW boilers)

**NOTICE** The modulating signal from U-Control P16 of one boiler to P15 of the next is polarity sensitive.

Connect wires + to + and - to - as shown. That is, P16-1 goes to P15-6 and P16-2 goes to P15-5.

**NOTICE** Set the ADD'L HEAT DEMAND TIME to 5 minutes, or longer if possible. This is the time delay before the modulating signal will be passed on to the next boiler in series for additional space heating capacity.

**NOTICE** Install system SUPPLY and RETURN sensors and OUTDOOR sensor for every boiler, as shown in the piping and wiring diagrams for this application. Shadow boilers will only start and stop based on their MODULATE ON or OFF DIFF. This reduces the likelihood of excessive cycling as heat demand changes.

Non-DHW SHADOW Boiler U-Control settings			
xxx	— VALUE MUST BE SET (OR VERIFIED) AS LISTED	See other boiler settings on pages 48 and 51	
D	— DEFAULT ACCEPTABLE; CHANGE ONLY IF DESIRED		
BOILER SETTINGS			
BOILER MODEL	Verify model number is correct		
HIGH ALTITUDE	Set to YES if high altitude		
HIGH LIMIT	D		
WWSD TEMP	DEFAULT (70 °F) OR AS REQUIRED		
ADJUST OUTDOOR	DEFAULT (0 °F) OR AS REQUIRED		
ADD'L HEAT DEMAND TYPE	Type 4 – SHADOW		
ADD'L HEAT DEMAND TIME	5 minutes		
SYSTEM SETTINGS			
<b>BOILER PRIORITY 1</b> Space heating (any type)	SYSTEM TYPE	Select from list	SAME AS LEAD
	TEMPERATURES	Max Supply	SAME AS LEAD
		Min Supply	SAME AS LEAD
		Max OD Reset	SAME AS LEAD
		Min OD Reset	SAME AS LEAD
		Modulate On Diff	5 F
	TIMES	Modulate Off Diff	10 F
		Max On Time	D
	CIRCULATORS	Boost Interval	D
		Prepump Time:	D
Postpump Time:		D	
MAXIMUM RATE	Circulator 1	OFF	
	Circulator 2	ON	
	Circulator 3	OFF	
MINIMUM RATE		D	
<del>BOILER PRIORITY 2</del> Not used	SYSTEM TYPE	Select from list	D
	TEMPERATURES	Max Supply	D
		Min Supply	D
		Max OD Reset	D
		Min OD Reset	D
		Modulate On Diff	D
	TIMES	Modulate Off Diff	D
		Max On Time	D
	CIRCULATORS	Min On Time	D
		Boost Interval	D
Prepump Time:		D	
MAXIMUM RATE	Postpump Time:	D	
	Circulator 1	D	
	Circulator 2	D	
MINIMUM RATE		D	
<del>BOILER PRIORITY 3</del> Not used	SYSTEM TYPE	Select from list	D
	TEMPERATURES	Max Supply	D
		Min Supply	D
		Max OD Reset	D
		Min OD Reset	D
		Modulate On Diff	D
	TIMES	Modulate Off Diff	D
		Min On Time	D
	CIRCULATORS	Boost Interval	D
		Prepump Time:	D
Postpump Time:		D	
MAXIMUM RATE	Circulator 1	D	
	Circulator 2	D	
	Circulator 3	D	
MINIMUM RATE		D	
CIRCULATOR EXERCISING	Circulator 1	D	
FREEZE PROTECT CIRCS	Circulator 2	D	
	Circulator 3	D	
		D	



# Application 18 — Multiple boilers (continued)

Multiple Ultra boilers | Multiple-zone SPACE HEATING (Circulators with WMCR) | DHW (Direct-connected)

## U-Control setting notes (LAST SHADOW boiler)

**NOTICE** The modulating signal from U-Control P16 of one boiler to P15 of the next is polarity sensitive.

Connect wires + to + and - to - as shown. That is, P16-1 goes to P15-6 and P16-2 goes to P15-5.

**NOTICE** The indirect water heater must be connected to the LAST boiler in the sequence. This ensures that the modulating signal from previous boilers will be passed along to the next boiler.

**NOTICE** Set the last SHADOW boiler Priority 1 MAX ON TIME to 0 minutes. The boiler will immediately switch to DHW mode on call from the DHW aquastat. MAX ON TIME is the maximum time the boiler will continue to operate under the current PRIORITY if a lower priority is calling for heat.

**NOTICE** Install system SUPPLY and RETURN sensors and OUTDOOR sensor for every boiler. Shadow boilers will start and stop based on their MODULATE ON or OFF DIFF. This reduces the likelihood of excessive cycling as heat demand changes.

**NOTICE** Select DHW DIRECT for the DHW BOILER PRIORITY 2. This informs the control that the DHW tank is directly connected to the boiler.

DHW SHADOW Boiler U-Control settings			
<p>xxx D</p>		<p>— VALUE MUST BE SET (OR VERIFIED) AS LISTED</p> <p>— DEFAULT ACCEPTABLE; CHANGE ONLY IF DESIRED</p>	<p>See other boiler settings on pages 48 and 50</p>
BOILER SETTINGS		SET TO	
BOILER MODEL	Verify model number is correct		
HIGH ALTITUDE	Set to YES if high altitude		
HIGH LIMIT	D		
WWSD TEMP	OPT		
ADJUST OUTDOOR	OPT		
ADD'L HEAT DEMAND TYPE	Type 4 – SHADOW		
ADD'L HEAT DEMAND TIME	D		
SYSTEM SETTINGS	NEXT MENU	NEXT MENU	SET TO
<p><b>BOILER PRIORITY 1</b></p> <p><b>Space heating</b></p>	SYSTEM TYPE	Select from list	SAME AS LEAD
	TEMPERATURES	Max Supply	SAME AS LEAD
		Min Supply	SAME AS LEAD
		Max OD Reset	SAME AS LEAD
		Min OD Reset	SAME AS LEAD
		Modulate On Diff	10 F
	TIMES	Modulate Off Diff	5 F
		Max On Time	0 minutes
	CIRCULATORS	Boost Interval	D
		Prepump Time:	D
Postpump Time:		D	
MAXIMUM RATE	Circulator 1	OFF	
	Circulator 2	ON	
MINIMUM RATE	Circulator 3	OFF	
		OFF	
<p><b>BOILER PRIORITY 2</b></p> <p><b>DHW</b></p>	SYSTEM TYPE	Select from list	DHW-DIRECT
	TEMPERATURES	Max Supply	190 F
		Max OD Reset	D
		Min OD Reset	D
		Modulate On Diff	D
		Modulate Off Diff	D
	TIMES	Max On Time	D
		Min On Time	60 minutes
		Boost Interval	D
	CIRCULATORS	Prepump Time:	D
Postpump Time:		D	
Circulator 1		ON	
MAXIMUM RATE	Circulator 2	OFF	
	Circulator 3	OFF	
MINIMUM RATE		OFF	
		OFF	
<p><b>BOILER PRIORITY 3</b></p> <p><b>Not used</b></p>	SYSTEM TYPE	Select from list	D
	TEMPERATURES	Max Supply	D
		Min Supply	D
		Max OD Reset	D
		Min OD Reset	D
		Modulate On Diff	D
	TIMES	Modulate Off Diff	D
		Min On Time	D
		Boost Interval	D
	CIRCULATORS	Prepump Time:	D
Postpump Time:		D	
Circulator 1		D	
MAXIMUM RATE	Circulator 2	D	
	Circulator 3	D	
MINIMUM RATE		D	
		D	
CIRCULATOR EXERCISING	Circulator 1	D	
	Circulator 2	D	
	Circulator 3	D	
FREEZE PROTECT CIRC	Circulator 1	D	
	Circulator 2	D	
	Circulator 3	D	



# Application 19 — Multiple boilers

Multiple Ultra boilers | Multi-zone SPACE HEATING & DHW (In system) (Circulators with WMCR controllers)

## Purpose

- Space heating with multiple Ultra boilers, and baseboard or fan coils, with DHW supplied by system piping.
- DHW connected to primary with a secondary connection. Multiple DHW tanks are zoned with circulators.
- DHW priority (accomplished using a SPST relay, item 42, not through the U-Control) — space heating is disabled during call for heat from water heater.

## Circulators and piping

### DHW

- DHW circulators supplied by installer.
- The SPST relay (item 42) set for DHW priority disables space heating as long as the U-Control Circulator 3 output is activated — the duration of this domestic priority operation is determined by the LEAD boiler's Priority 1 MAX ON TIME setting. Set this value to 60 minutes for typical application. This time can be changed to suit job requirements. OMIT relay 42 if domestic priority is not required.

### BASEBOARD

- Size circulators for required flow.
- All zone circulators supplied by installer.

*continued*

## LEGEND

- \* = Supplied by installer
- 1 DHW circulators \*
- 2 BOILER circulators (shipped loose with boiler)
- 3 Zone circulators \*
- 4 120VAC power supply, 15-amp minimum rating
- 5 U-Control
- 6 Zone thermostats \*
- 7 Supply temperature sensor — strap to supply line
- 8 Return temperature sensor — strap to return line
- 9 DHW tank aquastats or sensor\*
- 10 Outdoor temperature sensor (supplied with boiler; install if U-Control will be set for outdoor reset operation)
- 11 Low water cutoff (if used) \*
- 12 Circulator zone controller for baseboard or fan coil zones \*
- 13 Circulator zone controller for DHW circulators \*
- 21 Ultra boilers
- 22 Indirect water heaters \*
- 23 Flow/check valves \*
- 24 Air separator with automatic air vent \*
- 25 Diaphragm-type expansion tank \*
- 26 Fresh water supply — install per applicable codes \*
- 27 Isolation valves \*
- 28 Purge/drain valves \*
- 29 Secondary piping connection for boiler loop \*
- 30 Boiler relief valve (install per boiler manual)
- 31 DHW Temperature and Pressure relief valve (install per boiler manual)
- 40 Weil-McLain Easy-Fit headers (or field-fabricated equivalent) for connection of boiler or water heater piping to primary loop \*
- 41 Distribution manifolds for piping to baseboard or fan coil zones \*
- 42 SPST relay, 120 VAC coil, normally open — when closed, the space heating circulator controller senses the priority zone is active and will prevent other space heating zones from running until the closure on the priority zone ends

## FIELD WIRING

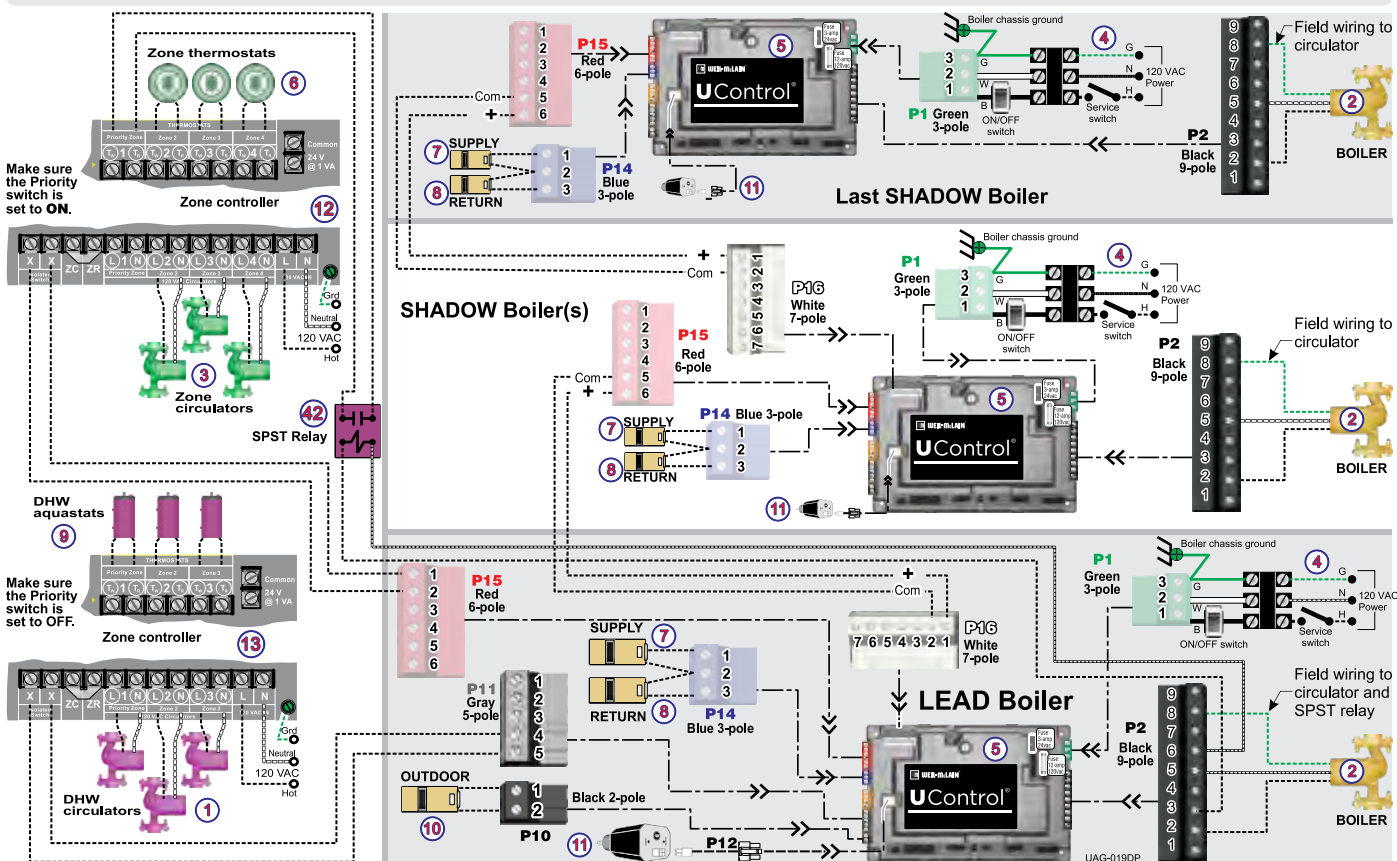



**PIPING**

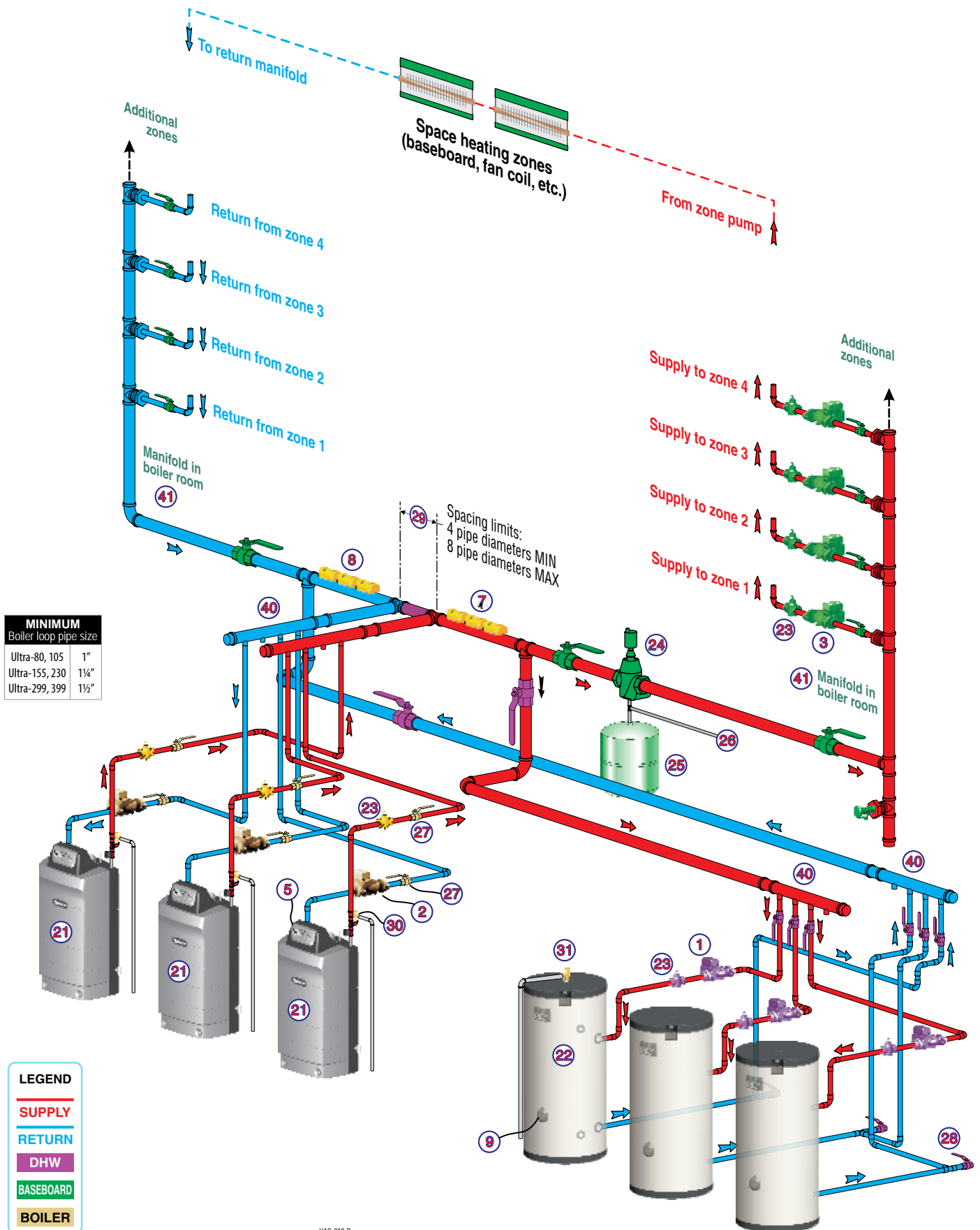

MINIMUM Boiler loop pipe size	
Ultra-80, 105	1"
Ultra-155, 230	1¼"
Ultra-299, 399	1½"

**LEGEND**

- SUPPLY
- RETURN
- DHW
- BASEBOARD
- BOILER

UAG-019-P



# Application 19 — Multiple boilers (continued)

Multiple Ultra boilers | Multi-zone SPACE HEATING & DHW (In system) (Circulators with WMCR controllers)

## BOILER

- Piping must be primary/secondary as shown, with the boiler piped in a secondary loop and the DHW piped in a secondary loop with connections spanning the boiler connections.
- See boiler manual for sizing.
- Circulator shipped loose with each boiler.

## Wiring

- Connect field wiring as shown on page 52.
- For circulators connected to the U-Control, the maximum circulator load is 2.2 amps each — if load is higher, provide a circulator relay or contactor for circulator power.
- Provide two circulator zone controllers — one for DHW circulator zoning and the other for baseboard or fan coil zoning.
- Provide SPST relay, 120 VAC coil, normally open contact if domestic priority is required. (This configuration uses the priority zone of the space heating WMCR zone controller.)

## U-Control setting notes

- See the tables on pages 54 and 55 for required and optional settings.
- To see the navigation sequence to access the BOILER SETTINGS and SYSTEM SETTINGS menus, see page 7.

**NOTICE**

The modulating signal from U-Control P16 of one boiler to P15 of the next is polarity sensitive.

Connect wires + to + and – to – as shown. That is, P16–1 goes to P15–6 and P16–2 goes to P15–5.

**NOTICE**

**DO NOT** set any boiler's PRIORITY 1 SYSTEM TYPE to Custom or DHW-DIRECT. Shadow boilers set to TYPE 4 will not work with these settings.

**NOTICE**

**DO NOT** set the U-Controls for outdoor reset operation. The system must provide boiler water suitable for DHW operation.

**NOTICE**

Install system SUPPLY and RETURN sensors for every boiler.

**NOTICE**

Set the ADD'L HEAT DEMAND TIME to 5 minutes, or as desired. This is the time delay before the modulating signal will be passed on to the next boiler in series for additional heating capacity.

**NOTICE**

**DHW OPERATION — ADDITIONAL HEAT DEMAND TIME:** The additional heat demand time setting may have to be 0 minutes if the DHW demand is large compared to total boiler capacity. If the timing is too long, the boilers will not provide fast enough response.

**NOTICE**

The MAX ON TIME setting for Priority 1 will disable space heating for this amount of time. At the end of this time, the U-Control will switch to Priority 2

## LEAD Boiler U-Control settings

xxx	— VALUE MUST BE SET (OR VERIFIED) AS LISTED	See SHADOW boiler settings on pages 55
D	— DEFAULT ACCEPTABLE; CHANGE ONLY IF DESIRED	

### BOILER SETTINGS

BOILER MODEL	Verify model number is correct
HIGH ALTITUDE	Set to YES if high altitude
HIGH LIMIT	D
WWSD TEMP	DEFAULT (70 °F) OR AS REQUIRED
ADJUST OUTDOOR	DEFAULT (0 °F) OR AS REQUIRED
ADD'L HEAT DEMAND TYPE	Type 3 – LEAD
ADD'L HEAT DEMAND TIME	5 minutes (see NOTICE on page 54)

### SYSTEM SETTINGS

<b>BOILER PRIORITY 1</b>  <b>DHW</b> <i>(must be set up as DHW-SYSTEM)</i>	SYSTEM TYPE	Select from list	DHW-SYSTEM
	TEMPERATURES	Max Supply	190 F
		Max OD Reset	D
		Min OD Reset	D
		Modulate On Diff	D
		Modulate Off Diff	D
	TIMES	Max On Time	60 minutes
		Boost Interval	D
		Prepump Time: Postpump Time:	D D
	CIRCULATORS	Circulator 1	OFF
Circulator 2		ON	
Circulator 3		ON	
MAXIMUM RATE		D	
MINIMUM RATE		D	
<b>BOILER PRIORITY 2</b>  <b>Space heating</b> <i>(baseboard or fan coil)</i>	SYSTEM TYPE	Select from list	FTB or FCL
	TEMPERATURES	Max Supply	190 F
		Min Supply	190 F
		Max OD Reset	D
		Min OD Reset	D
		Modulate On Diff	D
	TIMES	Max On Time	D
		Boost Interval	D
		Prepump Time: Postpump Time:	D D
	CIRCULATORS	Circulator 1	OFF
Circulator 2		ON	
Circulator 3		OFF	
MAXIMUM RATE		D	
MINIMUM RATE		D	
<b>BOILER PRIORITY 3</b>  <b>Not used</b>	SYSTEM TYPE	Select from list	D
	TEMPERATURES	Max Supply	D
		Min Supply	D
		Max OD Reset	D
		Min OD Reset	D
		Modulate On Diff	D
	TIMES	Min On Time	D
		Boost Interval	D
		Prepump Time: Postpump Time:	D D
	CIRCULATORS	Circulator 1	D
Circulator 2		D	
Circulator 3		D	
MAXIMUM RATE		D	
MINIMUM RATE		D	
<b>CIRCULATOR EXERCISING</b>	Circulator 1 Circulator 2 Circulator 3		D D D
<b>FREEZE PROTECT CIRCS</b>	Circulator 1 Circulator 2 Circulator 3		D D D



## Application 19 — Multiple boilers (continued)

**Multiple Ultra boilers | Multi-zone SPACE HEATING & DHW (In system) (Circulators with WMCR controllers)**

<b>SHADOW Boiler U-Control settings</b>				
xxx		— VALUE MUST BE SET (OR VERIFIED) AS LISTED	See LEAD boiler settings on pages 54	
D		— DEFAULT ACCEPTABLE; CHANGE ONLY IF DESIRED		
<b>BOILER SETTINGS</b>				
BOILER MODEL		Verify model number is correct		
HIGH ALTITUDE		Set to YES if high altitude		
HIGH LIMIT		D		
WWSD TEMP		OPT		
ADJUST OUTDOOR		OPT		
ADD'L HEAT DEMAND TYPE		Type 4 – SHADOW		
ADD'L HEAT DEMAND TIME		5 minutes (see NOTICE on page 54)		
<b>SYSTEM SETTINGS</b>				
<b>BOILER PRIORITY 1</b>  Space heating (baseboard or fan coil)	SYSTEM TYPE	Select from list	FTB or FCL	
	TEMPERATURES	Max Supply		190 F
		Min Supply		D
		Max OD Reset		D
		Min OD Reset		D
		Modulate On Diff		D
		Modulate Off Diff		D
	TIMES	Max On Time		D
		Boost Interval		D
		Prepump Time: Postpump Time:		D
	CIRCULATORS	Circulator 1		OFF
		Circulator 2		ON
		Circulator 3		OFF
	MAXIMUM RATE			D
MINIMUM RATE			D	
<del>                         BOILER PRIORITY 2                           Not used                     </del>	SYSTEM TYPE	Select from list	D	
	TEMPERATURES	Max Supply		D
		Min Supply		D
		Max OD Reset		D
		Min OD Reset		D
		Modulate On Diff		D
		Modulate Off Diff		D
	TIMES	Max On Time		D
		Min On Time		D
		Boost Interval Prepump Time: Postpump Time:		D
	CIRCULATORS	Circulator 1		D
		Circulator 2		D
		Circulator 3		D
	MAXIMUM RATE			D
MINIMUM RATE			D	
<del>                         BOILER PRIORITY 3                           Not used                     </del>	SYSTEM TYPE	Select from list	D	
	TEMPERATURES	Max Supply		D
		Min Supply		D
		Max OD Reset		D
		Min OD Reset		D
		Modulate On Diff		D
		Modulate Off Diff		D
	TIMES	Min On Time		D
		Boost Interval		D
		Prepump Time: Postpump Time:		D
	CIRCULATORS	Circulator 1		D
		Circulator 2		D
		Circulator 3		D
	MAXIMUM RATE			D
MINIMUM RATE			D	
CIRCULATOR EXERCISING	Circulator 1 Circulator 2 Circulator 3		D D D	
FREEZE PROTECT CIRC	Circulator 1 Circulator 2 Circulator 3		D D D	



# Application 20 — Multiple boilers

Multiple Ultra boilers | Multiple loads on SECONDARY loops | DHW (Direct-connected)

## Purpose

- Space heating with multiple Ultra boilers, with multiple-zone baseboard space heating.
- DHW piped directly to one boiler.
- DHW priority — space heating and heater exchanger heating are disabled during call for heat from water heater.

## Circulators and piping

### PRIMARY PIPING

- Provides crossover-style connection for multiple subsystems. Each subsystem connects via a secondary loop take-off.
- Size circulator for required flow — primary (system) circulator supplied by installer.

### SUBSYSTEMS

- Subsystem supply/return piping must be connected to crossover bridges with secondary connections spaced apart as shown.
- Subsystems can use any means desired, such as baseboard, cast iron radiators, fan coils, heat exchanger or radiant.
- Provide controls and components needed for zoning (as shown in typical subsystem example).

continued

## LEGEND

- \* = Supplied by installer
- |  |  |
|--|--|
| 1 DHW circulator *   | 22 Indirect water heater *   |
| 2 BOILER circulators (shipped loose with boiler)   | 23 Flow/check valves *   |
| 3 System circulator *  | 24 Air separator with automatic air vent *   |
| 4 120VAC power supply, 15-amp minimum rating   | 25 Diaphragm-type expansion tank *   |
| 5 U-Control  | 26 Fresh water supply — install per applicable codes *   |
| 6 Zone thermostats, typical *  | 27 Isolation valves *  |
| 7 Supply temperature sensor — strap to supply line   | 28 Purge/drain valves *  |
| 8 Return temperature sensor — strap to return line   | 29 Secondary piping connection for boiler loop *   |
| 9 DHW tank aquastat or sensor*   | 30 Boiler relief valve (install per boiler manual)   |
| 10 Outdoor temperature sensor (supplied with boiler; install if U-Control will be set for outdoor reset operation) | 31 DHW Temperature and Pressure relief valve (install per boiler manual)   |
| 11 Low water cutoff (if used) *  | 40 Weil-McLain Easy-Fit headers (or field-fabricated equivalent) for connection of boiler or water heater piping to primary loop * |
| 12 Typical — circulator zone controller for baseboard or fan coil zones *  | 41 Distribution manifolds for piping to baseboard or fan coil zones *  |
| 16 Baseboard zone circulators *  | 43 Balancing valves *  |
| 21 Ultra boilers   | 45 Secondary connections to heating subsystems *   |

## FIELD WIRING

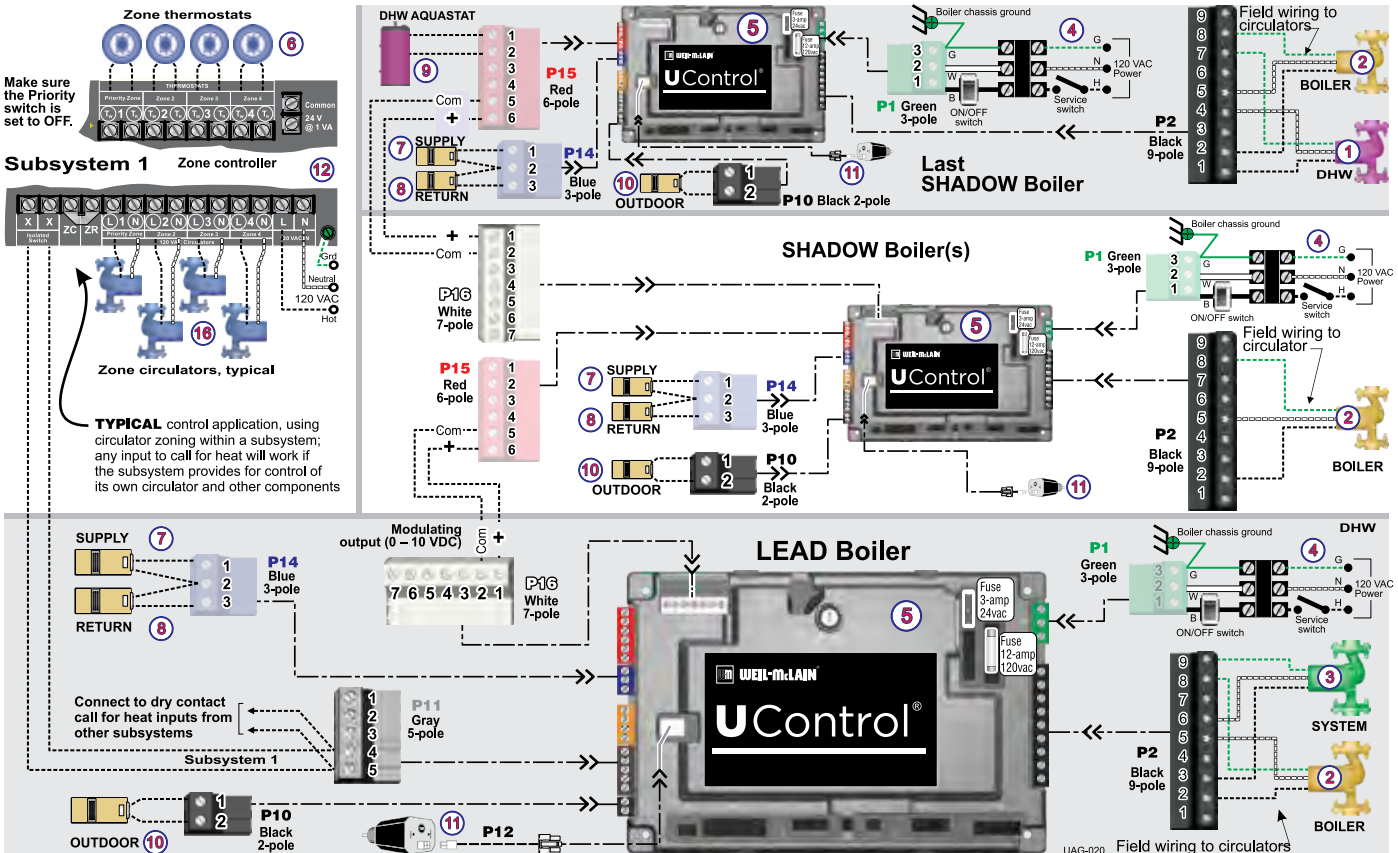





**PIPING**

**Piping overview**

- Piping uses a crossover bridge for each subsystem. The subsystem supply and return pipes must be connected using a secondary connection from the bridge as shown.
- Use the balancing valves in the crossover bridge lines to balance flow as needed.
- A typical subsystem comprised of base-board heating zones with zone circulators is illustrated. The wiring diagram on the opposite page shows the circulator zoning panel for this subsystem.
- Other subsystems could provide heat for radiant heating, fan coil units, pool heat exchangers, etc.
- Domestic hot water is supplied by an indirect water heater piped to the last boiler in the LEAD/SHADOW sequence. When the DHW aquastat calls for heat, the boiler circulator turns off and the DHW circulator turns on. Other boilers continue to provide heat to the system.
- The major advantage to the two-pipe primary/secondary method shown here is that all subsystems receive supply water at the same temperature. In contrast, a one-pipe primary/secondary system loses temperature as heat is extracted by subsystems around its perimeter.

MINIMUM Boiler loop pipe size	
Ultra-80, 105	1"
Ultra-155, 230	1¼"
Ultra-299, 399	1½"

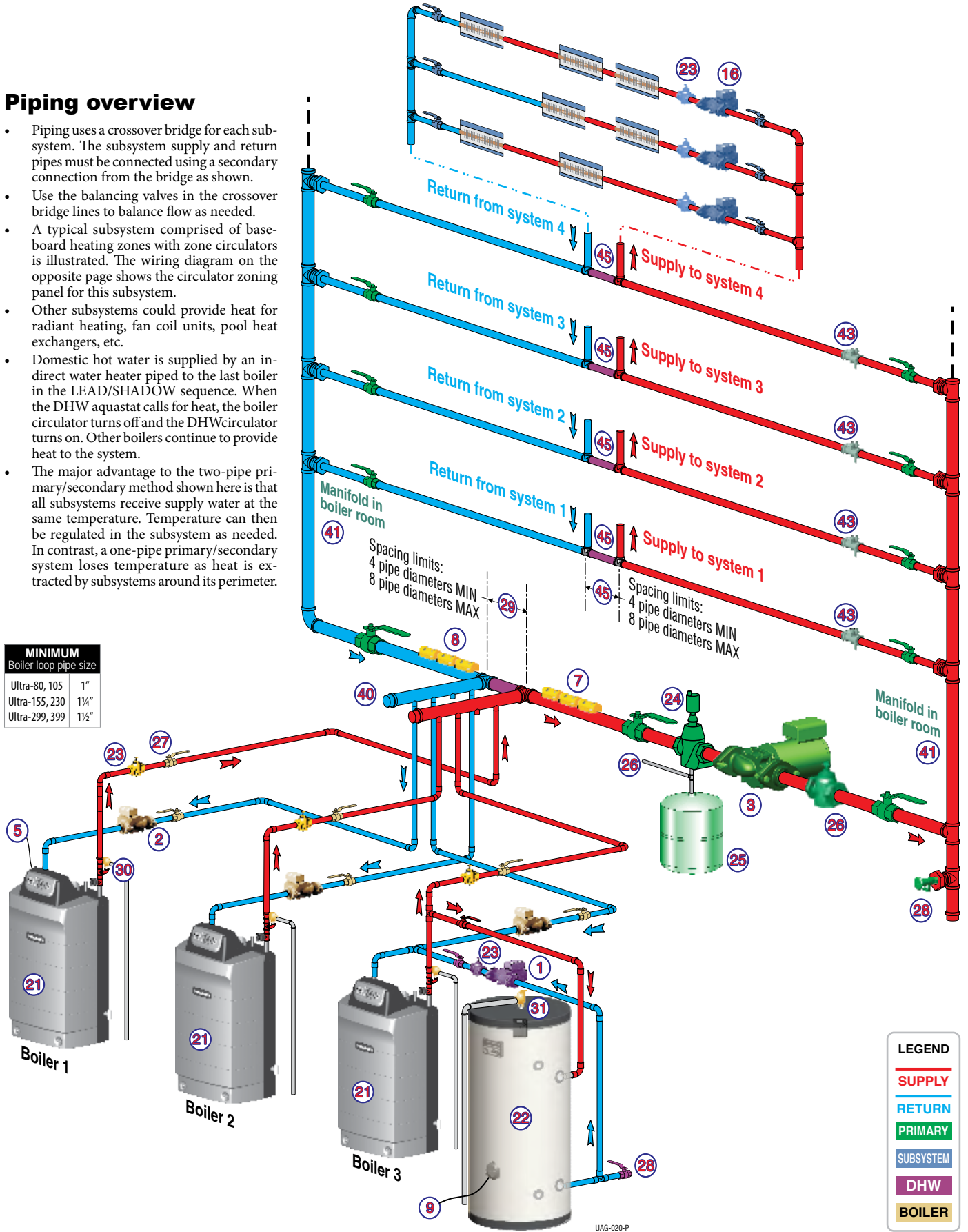

**LEGEND**

- SUPPLY
- RETURN
- PRIMARY
- SUBSYSTEM
- DHW
- BOILER



# Application 20 — Multiple boilers (continued)

Multiple Ultra boilers | Multiple loads on SECONDARY loops | DHW (Direct-connected)

## DHW

- DHW circulator must be selected to handle the pressure drop through the Ultra boiler, water heater and piping — see boiler manual for recommended sizing. DHW circulator supplied by installer.
- For some large indirect water heaters, the required flow rate may require piping the water heater differently — see boiler manual and other applications in this guide.
- Pipe the indirect water heater to the last SHADOW boiler. The U-Control on the last SHADOW boiler is set to immediately switch to DHW heating on call from the DHW aquastat. Set system type to DHW-DIRECT.

## BOILER

- Ultra boiler piping must be primary/secondary as shown, with the boiler piped in a secondary loop and the DHW piped to the last SHADOW boiler.
- See boiler manual for sizing.
- Circulator shipped loose with boiler.

## Wiring

- Connect field wiring as shown on page 56.
- For circulators connected to the U-Control, the maximum circulator load is 2.2 amps each — if load is higher, provide a circulator relay or contactor for circulator power.
- Provide all piping and controls needed for each subsystem connected.

## U-Control setting notes

- See the tables on pages 58 and 59 for required and optional settings.
- To see the navigation sequence to access the BOILER SETTINGS and SYSTEM SETTINGS menus, see page 7.

**NOTICE**

The modulating signal from U-Control P16 of one boiler to P15 of the next is polarity sensitive. Connect wires + to + and – to – as shown. That is, P16–1 goes to P15–6 and P16–2 goes to P15–5.

**NOTICE**

Set the ADD'L HEAT DEMAND TIME to 5 minutes, or as desired. This is the time delay before the modulating signal will be passed on to the next boiler in series for additional space heating capacity.

**NOTICE**

**DO NOT** set the LEAD boiler PRIORITY 1 SYSTEM TYPE to Custom or DHW. Shadow boilers set to TYPE 4 will not work with these settings.

**NOTICE**

**LAST SHADOW boiler only** — Select DHW DIRECT for the DHW BOILER PRIORITY 2. This informs the control that the DHW tank is directly connected to the boiler

**NOTICE**

Install system SUPPLY and RETURN sensors and OUTDOOR sensor for every boiler, as shown in the piping and wiring diagrams for this application. Shadow boilers will only start and stop based on their MODULATE ON or OFF DIFF. This reduces the likelihood of excessive cycling as heat demand changes.

**NOTICE**

**Set the last SHADOW boiler MAX ON TIME to 0 minutes.** The boiler will immediately switch to DHW mode on call from the DHW aquastat.

## LEAD Boiler U-Control settings

xxx	— VALUE MUST BE SET (OR VERIFIED) AS LISTED	See SHADOW boiler settings on page 59
D	— DEFAULT ACCEPTABLE; CHANGE ONLY IF DESIRED	

### BOILER SETTINGS

BOILER MODEL	Verify model number is correct
HIGH ALTITUDE	Set to YES if high altitude
HIGH LIMIT	D
WWSD TEMP	DEFAULT (70 °F) OR AS REQUIRED
ADJUST OUTDOOR	DEFAULT (0 °F) OR AS REQUIRED
ADD'L HEAT DEMAND TYPE	Type 3 – LEAD
ADD'L HEAT DEMAND TIME	5 minutes

### SYSTEM SETTINGS

<b>BOILER PRIORITY 1</b> Select system type most representative of subsystems connected	SYSTEM TYPE	Select from list	Select
	TEMPERATURES	Max Supply	180 F
		Min Supply	D (70F) OR AS
		Max OD Reset	D (0F) OR AS
		Min OD Reset	D OR AS REQUIRED
		Modulate On Diff	D
	TIMES	Modulate Off Diff	D
		Max On Time	D
		Boost Interval	D
	CIRCULATORS	Prepump Time:	D
		Postpump Time:	D
		Circulator 1	OFF
MAXIMUM RATE	Circulator 2	ON	
	Circulator 3	ON	
MINIMUM RATE		D	
<del>                     BOILER PRIORITY 2                      Not used                 </del>	SYSTEM TYPE	Select from list	D
	TEMPERATURES	Max Supply	D
		Min Supply	D
		Max OD Reset	D
		Min OD Reset	D
		Modulate On Diff	D
	TIMES	Modulate Off Diff	D
		Min On Time	D
		Boost Interval	D
	CIRCULATORS	Prepump Time:	D
		Postpump Time:	D
		Circulator 1	D
MAXIMUM RATE	Circulator 2	D	
	Circulator 3	D	
MINIMUM RATE		D	
<del>                     BOILER PRIORITY 3                      Not used                 </del>	SYSTEM TYPE	Select from list	D
	TEMPERATURES	Max Supply	D
		Min Supply	D
		Max OD Reset	D
		Min OD Reset	D
		Modulate On Diff	D
	TIMES	Modulate Off Diff	D
		Min On Time	D
		Boost Interval	D
	CIRCULATORS	Prepump Time:	D
		Postpump Time:	D
		Circulator 1	D
MAXIMUM RATE	Circulator 2	D	
	Circulator 3	D	
MINIMUM RATE		D	
CIRCULATOR EXERCISING	Circulator 1	D	
	Circulator 2	D	
	Circulator 3	D	
FREEZE PROTECT CIRCS	Circulator 1	D	
	Circulator 2	D	
	Circulator 3	D	



# Application 20 — Multiple boilers (continued)

Multiple Ultra boilers | Multiple loads on SECONDARY loops | DHW (Direct-connected)

## Non-DHW SHADOW Boiler U-Control settings

<b>xxx</b>	— VALUE MUST BE SET (OR VERIFIED) AS LISTED	See LEAD boiler settings on page 58
<b>D</b>	— DEFAULT ACCEPTABLE; CHANGE ONLY IF DESIRED	

### BOILER SETTINGS

BOILER MODEL	<b>Verify model number is correct</b>
HIGH ALTITUDE	<b>Set to YES if high altitude</b>
HIGH LIMIT	D
WWSD TEMP	<b>OPT</b>
ADJUST OUTDOOR	<b>OPT</b>
ADD'L HEAT DEMAND TYPE	<b>Type 4 – SHADOW</b>
ADD'L HEAT DEMAND TIME	<b>5 minutes</b>

### SYSTEM SETTINGS

<b>BOILER PRIORITY 1</b> Space heating	SYSTEM TYPE	Select from list	<b>SAME AS LEAD</b>
	TEMPERATURES	Max Supply	<b>SAME AS LEAD</b>
		Min Supply	<b>SAME AS LEAD</b>
		Max OD Reset	<b>SAME AS LEAD</b>
		Min OD Reset	<b>SAME AS LEAD</b>
		Modulate On Diff	<b>5 F</b>
		Modulate Off Diff	<b>10 F</b>
	TIMES	Max On Time	D
		Boost Interval Prepump Time: Postpump Time:	D D D
	CIRCULATORS	Circulator 1	<b>OFF</b>
Circulator 2		<b>ON</b>	
Circulator 3		<b>OFF</b>	
MAXIMUM RATE		D	
MINIMUM RATE		D	
<del><b>BOILER PRIORITY 2</b> Not used</del>	SYSTEM TYPE	Select from list	D
	TEMPERATURES	Max Supply	D
		Min Supply	D
		Max OD Reset	D
		Min OD Reset	D
		Modulate On Diff	D
		Modulate Off Diff	D
	TIMES	Max On Time Min On Time Boost Interval Prepump Time: Postpump Time:	D D D D D
		CIRCULATORS	Circulator 1
	Circulator 2		D
Circulator 3	D		
MAXIMUM RATE		D	
MINIMUM RATE		D	
<del><b>BOILER PRIORITY 3</b> Not used</del>	SYSTEM TYPE	Select from list	D
	TEMPERATURES	Max Supply	D
		Min Supply	D
		Max OD Reset	D
		Min OD Reset	D
		Modulate On Diff	D
		Modulate Off Diff	D
	TIMES	Min On Time Boost Interval Prepump Time: Postpump Time:	D D D D
		CIRCULATORS	Circulator 1
	Circulator 2		D
Circulator 3	D		
MAXIMUM RATE		D	
MINIMUM RATE		D	
CIRCULATOR EXERCISING	Circulator 1 Circulator 2 Circulator 3	D D D	
FREEZE PROTECT CIRCS	Circulator 1 Circulator 2 Circulator 3	D D D	

## DHW SHADOW Boiler U-Control settings

<b>xxx</b>	— VALUE MUST BE SET (OR VERIFIED) AS LISTED	See LEAD boiler settings on page 58
<b>D</b>	— DEFAULT ACCEPTABLE; CHANGE ONLY IF DESIRED	

### BOILER SETTINGS

BOILER MODEL	<b>Verify model number is correct</b>
HIGH ALTITUDE	<b>Set to YES if high altitude</b>
HIGH LIMIT	D
WWSD TEMP	<b>OPT</b>
ADJUST OUTDOOR	<b>OPT</b>
ADD'L HEAT DEMAND TYPE	<b>Type 4 – SHADOW</b>
ADD'L HEAT DEMAND TIME	D

### SYSTEM SETTINGS

<b>BOILER PRIORITY 1</b> Space heating	SYSTEM TYPE	Select from list	<b>SAME AS LEAD</b>
	TEMPERATURES	Max Supply	<b>SAME AS LEAD</b>
		Min Supply	<b>SAME AS LEAD</b>
		Max OD Reset	<b>SAME AS LEAD</b>
		Min OD Reset	<b>SAME AS LEAD</b>
		Modulate On Diff	<b>10 F</b>
		Modulate Off Diff	<b>5 F</b>
	TIMES	Max On Time	<b>0 minutes</b>
		Boost Interval Prepump Time: Postpump Time:	D D D
	CIRCULATORS	Circulator 1	<b>OFF</b>
Circulator 2		<b>ON</b>	
Circulator 3		<b>OFF</b>	
MAXIMUM RATE		D	
MINIMUM RATE		D	
<b>BOILER PRIORITY 2</b> DHW	SYSTEM TYPE	Select from list	<b>DHW-DIRECT</b>
	TEMPERATURES	Max Supply	<b>190 F</b>
		Max OD Reset	D
		Min OD Reset	D
		Modulate On Diff	D
		Modulate Off Diff	D
		TIMES	Max On Time Min On Time Boost Interval Prepump Time: Postpump Time:
	CIRCULATORS		Circulator 1
		Circulator 2	<b>OFF</b>
		Circulator 3	<b>OFF</b>
MAXIMUM RATE		D	
MINIMUM RATE		D	
<del><b>BOILER PRIORITY 3</b> Not used</del>	SYSTEM TYPE	Select from list	D
	TEMPERATURES	Max Supply	D
		Min Supply	D
		Max OD Reset	D
		Min OD Reset	D
		Modulate On Diff	D
		Modulate Off Diff	D
	TIMES	Min On Time Boost Interval Prepump Time: Postpump Time:	D D D D
		CIRCULATORS	Circulator 1
	Circulator 2		D
Circulator 3	D		
MAXIMUM RATE		D	
MINIMUM RATE		D	
CIRCULATOR EXERCISING	Circulator 1 Circulator 2 Circulator 3	D D D	
FREEZE PROTECT CIRCS	Circulator 1 Circulator 2 Circulator 3	D D D	



# Application 21 — Multiple boilers

BASE LOADING with ULTRA boilers | DHW (Direct connected)

## Purpose

- On an existing or new installation, provide base loading with high-efficiency Ultra boilers.
- Use a large boiler only as needed, such as during high heat demand periods (low outdoor temperature periods).
- The DPST switching relay, SPST relay and outdoor temperature control shown in this application automatically enable or disable the large boiler — at outdoor temperatures above the outdoor temperature control setting, the large boiler is not enabled. At colder outdoor temperatures, when the load is higher, the large boiler is enabled.
- An alternate method is to use a MOD-CON-CNC controller. This device provides automatic switching of base load boilers based on outdoor temperature and also provides boiler sequencing.
- The recommended temperature settings in this application are based on typical baseboard, radiator or fan coil systems. For radiant systems or any other lower temperature installation, set the U-Control and system aquastat temperatures as needed.

**NOTICE**

**DO NOT set the system aquastat (item 46) higher than 180°F.** The Ultra boilers will lockout if temperature exceeds 190°F. Set the Ultra LEAD boiler Priority 1 MAX SUPPLY temperature 20°F lower than the system aquastat setting.

- DHW is piped directly to one of the Ultra base load boilers. If additional DHW capacity is required, pipe the DHW units in a secondary loop as in Application 19 — Multiple boilers, page 52. DHW priority — space heating is disabled on the DHW boiler during call for heat from the water heater.

*continued*

## LEGEND

- \* = Supplied by installer
- |  |   |
|--|---|
| 1 DHW circulator *   | 25 Diaphragm-type expansion tank *  |
| 2 Ultra BOILER circulators (shipped loose with boiler)   | 26 Fresh water supply — install per applicable codes *  |
| 3 System circulator (typical in-line pump shown)*  | 27 Isolation valves *   |
| 4 120VAC power supply, 15-amp minimum rating   | 28 Purge/drain valves *   |
| 5 U-Control  | 29 Secondary piping connection for boiler loop *  |
| 7 Supply temperature sensor — strap to supply line   | 30 Boiler relief valve (install per boiler manual)  |
| 8 Return temperature sensor — strap to return line   | 31 DHW Temperature and Pressure relief valve (install per boiler manual)  |
| 9 DHW tank aquastat or sensor*   | 40 Weil-McLain Easy-Fit headers (or field-fabricated equivalent) for connection of Ultra boiler piping to primary loop *  |
| 10 Outdoor temperature sensor (supplied with boiler; install if U-Control will be set for outdoor reset operation) | 45 Large boiler, either existing or new installation — typically a commercial-sized forced draft boiler on existing installations — can be one or more forced draft boilers or one or more Ultra Commercial boilers for new or boiler replacement installations |
| 11 Low water cutoff (if used) *  | 46 System aquastat — See NOTICE at left   |
| 13 Relay, 120 VAC coil, SPST *   | 47 Outdoor temperature control (Honeywell T6031A or equivalent) — break on rise — to shut off large boiler(s) above the outdoor control setpoint (typically between 40°F and 50°F)  |
| 15 DPST switching relay *  | 48 System thermostat or system heat demand contact  |
| 21 Ultra boilers   |   |
| 22 Indirect water heater *   |   |
| 23 Flow/check valves *   |   |
| 24 Air separator with automatic air vent *   |   |

## FIELD WIRING

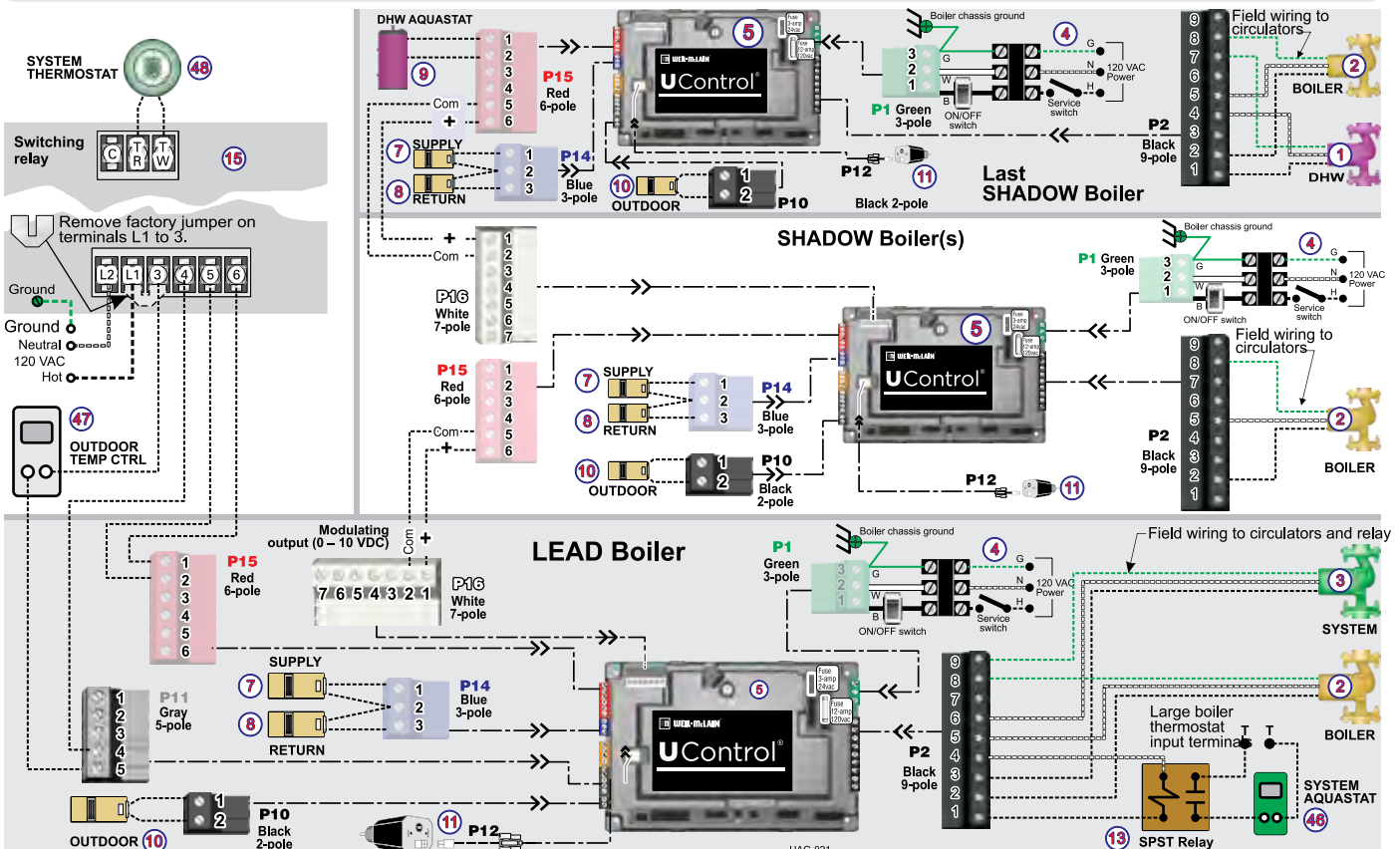



**PIPING**

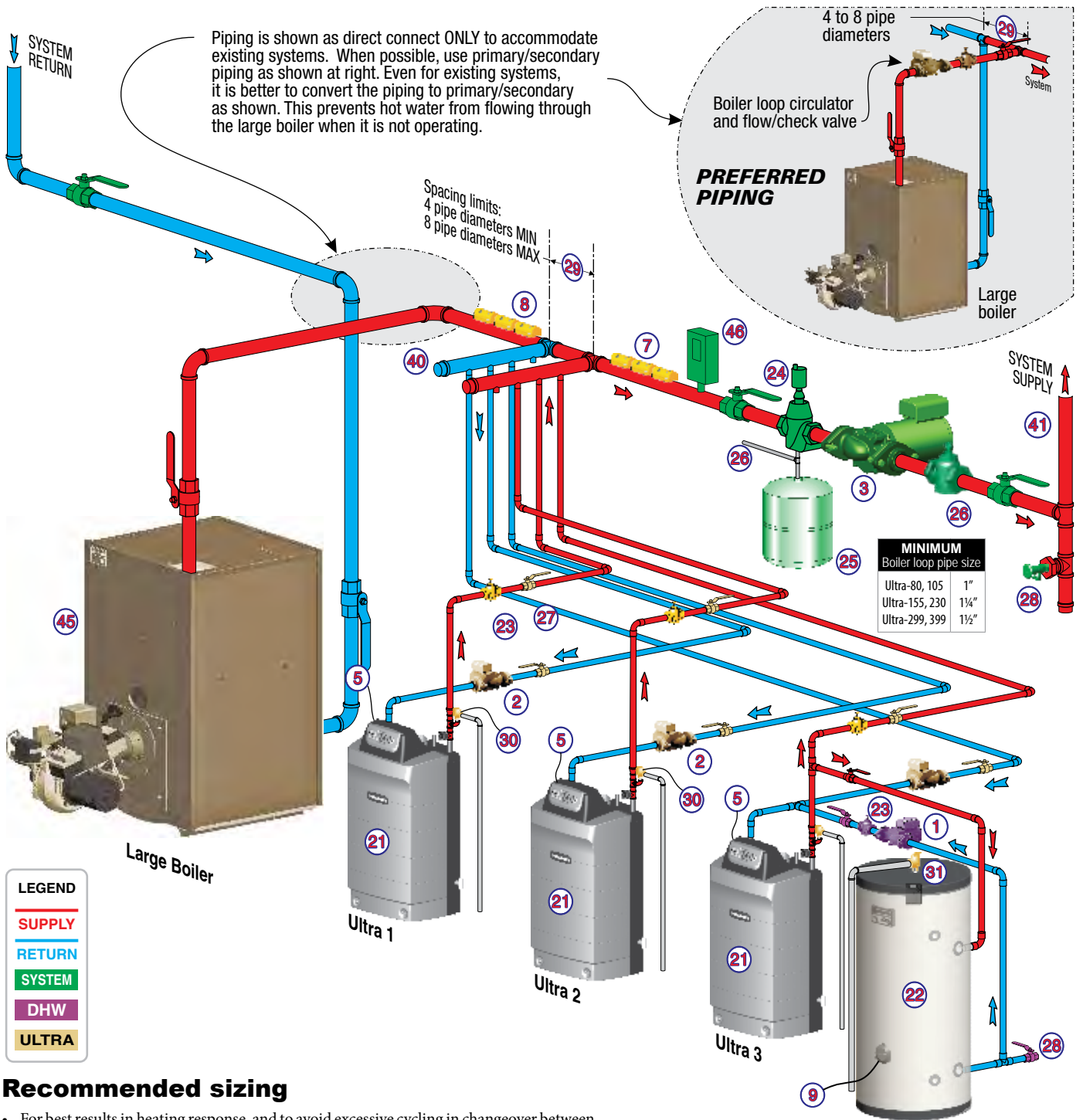

**Recommended sizing**

- For best results in heating response, and to avoid excessive cycling in changeover between boilers, size the Ultra boiler total input to at least the minimum input of the large boiler.
- If adding Ultra boilers for base loading with an existing large boiler, consider replacing the forced draft burner with a hi-lo or modulating burner. This will provide a turndown in boiler firing rate and reduce the recommended input for the base load boilers. It will also improve the large boiler's efficiency since the combustion efficiency will usually increase noticeably at low fire.

**Piping overview**

- This example can apply to an existing large boiler, such as a commercial-sized forced draft cast iron sectional boiler like the Weil-McLain 80 or 88 series.
- For a new system installation, you could use one or more Ultra Commercial boilers for the large boiler, with one or more Ultra Residential boilers for the base load units.

- The piping is shown with a conventional direct-connected system. The preferred method would be to pipe the large boiler(s) on a secondary loop as shown in the inset, upper right. The Ultra Residential boilers must be piped on a secondary loop as shown above.
- The indirect water heater is connected to one of the Ultra boilers, ensuring that DHW generation always takes advantage of the Ultra boiler's high efficiency.
- For each Ultra boiler, strap a supply sensor and return sensor to the system piping as shown.



# Application 21 — Multiple boilers (continued)

BASE LOADING with ULTRA boilers | DHW (Direct connected)

## SYSTEM PIPING

- Size system circulator for required flow — system circulator supplied by installer.
- Piping shown in this example is direct-connected, and is acceptable for an existing installation, but primary/secondary piping is preferred. For boiler replacement and new installations, use a secondary circuit for the large boiler(s) as shown in the piping diagram inset.

## DHW

- DHW circulator must be selected to handle the pressure drop through the Ultra boiler, water heater and piping — see boiler manual for recommended sizing. DHW circulator supplied by installer.
- For some large indirect water heaters, the required flow rate may require piping the water heater differently — see boiler manual and other applications in this guide.
- Pipe the indirect water heater to the last SHADOW boiler. The U-Control on the last SHADOW boiler is set to immediately switch to DHW heating on call from the DHW aquastat. Set system type to DHW-DIRECT.

## BOILER

- Ultra boiler piping must be primary/secondary as shown, with the boiler piped in a secondary loop and the DHW piped to the last SHADOW boiler.
- See boiler manual for sizing piping.
- Circulator shipped loose with boiler.

## Wiring

- Connect field wiring as shown on page 60.
- For circulators connected to the U-Control, the maximum circulator load is 2.2 amps each — if load is higher, provide a circulator relay or contactor for circulator power.
- Provide and install a DPST switching relay, a SPST relay with 120 VAC coil and an outdoor temperature control (Honeywell T6031A or equivalent). **Set the outdoor temperature control between 40°F and 50°F for most installations.** Mount the sensing bulb outside using an outdoor shield. Locate the bulb away from direct sunlight and in a location not subject to snow, ice or debris accumulation.

## U-Control setting notes

- See the tables on pages 62 and 63 for required and optional settings.
- To see the navigation sequence to access the BOILER SETTINGS and SYSTEM SETTINGS menus, see page 7.

**NOTICE**

The modulating signal from U-Control P16 of one boiler to P15 of the next is polarity sensitive.

Connect wires + to + and - to - as shown. That is, P16-1 goes to P15-6 and P16-2 goes to P15-5.

**NOTICE**

**DO NOT** set the LEAD boiler PRIORITY 1 SYSTEM TYPE to Custom or DHW DIRECT. Shadow boilers set to TYPE 4 will not work with these settings.

**NOTICE**

Install system SUPPLY and RETURN sensors and OUTDOOR sensor for every boiler. Shadow boilers will start and stop based on their MODULATE ON or OFF DIFF. This reduces the likelihood of excessive cycling as heat demand changes.

**NOTICE**

Set the ADD'L HEAT DEMAND TIME to 5 minutes, or longer if possible. This is the time delay before the modulating signal will be passed on to the next boiler in series.

**NOTICE**

**Set the last SHADOW boiler Priority 1 MAX ON TIME to 0 minutes.** The boiler will immediately switch to DHW mode on call from the DHW aquastat.

## LEAD Boiler U-Control settings

xxx	— VALUE MUST BE SET (OR VERIFIED) AS LISTED	See SHADOW boiler settings on page 59
D	— DEFAULT ACCEPTABLE; CHANGE ONLY IF DESIRED	

### BOILER SETTINGS

BOILER MODEL	Verify model number is correct
HIGH ALTITUDE	Set to YES if high altitude
HIGH LIMIT	D
WWSD TEMP	DEFAULT (70 °F) OR AS REQUIRED
ADJUST OUTDOOR	DEFAULT (0 °F) OR AS REQUIRED
ADD'L HEAT DEMAND TYPE	Type 3 – LEAD
ADD'L HEAT DEMAND TIME	5 minutes

### SYSTEM SETTINGS

	SYSTEM TYPE	Select from list	Select
<b>BOILER PRIORITY 1</b>  Large boiler enabled  Select system type most representative of subsystems connected	TEMPERATURES	Max Supply	160 F
		Min Supply	140 F
		Max OD Reset	70 F
		Min OD Reset	0 F
		Modulate On Diff	D
		Modulate Off Diff	D
	TIMES	Max On Time	15 minutes
		Boost Interval	D
		Prepump Time:	D
		Postpump Time:	D
CIRCULATORS	Circulator 1	ON	
	Circulator 2	ON	
	Circulator 3	ON	
MAXIMUM RATE		D	
MINIMUM RATE		D	
<b>BOILER PRIORITY 2</b>  Large boiler NOT enabled  Select system type most representative of subsystems connected	TEMPERATURES	Max Supply	190 F
		Min Supply	70 F
		Max OD Reset	70 F
		Min OD Reset	0 F
		Modulate On Diff	D
		Modulate Off Diff	D
	TIMES	Max On Time	15 minutes
		Min On Time	D
		Boost Interval	D
		Prepump Time:	D
	Postpump Time:	D	
	CIRCULATORS	Circulator 1	OFF
Circulator 2		ON	
Circulator 3		ON	
MAXIMUM RATE		D	
MINIMUM RATE		D	
<b>BOILER PRIORITY 3</b>  Not used	TEMPERATURES	Max Supply	D
		Min Supply	D
		Max OD Reset	D
		Min OD Reset	D
		Modulate On Diff	D
		Modulate Off Diff	D
	TIMES	Min On Time	D
		Boost Interval	D
		Prepump Time:	D
		Postpump Time:	D
CIRCULATORS	Circulator 1	D	
	Circulator 2	D	
	Circulator 3	D	
MAXIMUM RATE		D	
MINIMUM RATE		D	
CIRCULATOR EXERCISING	Circulator 1	D	
	Circulator 2	D	
	Circulator 3	D	
FREEZE PROTECT CIRC	Circulator 1	D	
	Circulator 2	D	
	Circulator 3	D	



# Application 21 — Multiple boilers (continued)

BASE LOADING with ULTRA boilers | DHW (Direct connected)

## Non-DHW SHADOW Boiler U-Control settings

<b>xxx</b>	— VALUE MUST BE SET (OR VERIFIED) AS LISTED	See LEAD boiler settings on page 58
<b>D</b>	— DEFAULT ACCEPTABLE; CHANGE ONLY IF DESIRED	

### BOILER SETTINGS

BOILER MODEL	<b>Verify model number is correct</b>
HIGH ALTITUDE	<b>Set to YES if high altitude</b>
HIGH LIMIT	D
WWSD TEMP	<b>OPT</b>
ADJUST OUTDOOR	<b>OPT</b>
ADD'L HEAT DEMAND TYPE	<b>Type 4 – SHADOW</b>
ADD'L HEAT DEMAND TIME	<b>5 minutes</b>

### SYSTEM SETTINGS

<b>BOILER PRIORITY 1</b> Space heating	SYSTEM TYPE	Select from list	<b>SAME AS LEAD</b>
	TEMPERATURES	Max Supply	<b>190 F</b>
		Min Supply	<b>70 F</b>
		Max OD Reset	<b>70 F</b>
		Min OD Reset	<b>0 F</b>
		Modulate On Diff	<b>5 F</b>
		Modulate Off Diff	<b>10 F</b>
	TIMES	Max On Time	D
		Boost Interval Prepump Time: Postpump Time:	D D D
	CIRCULATORS	Circulator 1	<b>OFF</b>
Circulator 2		<b>ON</b>	
Circulator 3		<b>OFF</b>	
MAXIMUM RATE		D	
MINIMUM RATE		D	
<b>BOILER PRIORITY 2</b> Not used	SYSTEM TYPE	Select from list	D
	TEMPERATURES	Max Supply	D
		Min Supply	D
		Max OD Reset	D
		Min OD Reset	D
		Modulate On Diff	D
		Modulate Off Diff	D
	TIMES	Max On Time	D
		Min On Time	D
		Boost Interval Prepump Time: Postpump Time:	D D D
Circulator 1 Circulator 2 Circulator 3		D D D	
MAXIMUM RATE		D	
MINIMUM RATE		D	
<b>BOILER PRIORITY 3</b> Not used	SYSTEM TYPE	Select from list	D
	TEMPERATURES	Max Supply	D
		Min Supply	D
		Max OD Reset	D
		Min OD Reset	D
		Modulate On Diff	D
		Modulate Off Diff	D
	TIMES	Min On Time	D
		Boost Interval Prepump Time: Postpump Time:	D D D
		Circulator 1 Circulator 2 Circulator 3	D D D
MAXIMUM RATE			D
MINIMUM RATE		D	
CIRCULATOR EXERCISING	Circulator 1 Circulator 2 Circulator 3	D D D	
FREEZE PROTECT CIRCS	Circulator 1 Circulator 2 Circulator 3	D D D	

## DHW SHADOW Boiler U-Control settings

<b>xxx</b>	— VALUE MUST BE SET (OR VERIFIED) AS LISTED	See LEAD boiler settings on page 58
<b>D</b>	— DEFAULT ACCEPTABLE; CHANGE ONLY IF DESIRED	

### BOILER SETTINGS

BOILER MODEL	<b>Verify model number is correct</b>
HIGH ALTITUDE	<b>Set to YES if high altitude</b>
HIGH LIMIT	D
WWSD TEMP	<b>OPT</b>
ADJUST OUTDOOR	<b>OPT</b>
ADD'L HEAT DEMAND TYPE	<b>Type 4 – SHADOW</b>
ADD'L HEAT DEMAND TIME	D

### SYSTEM SETTINGS

<b>BOILER PRIORITY 1</b> Space heating	SYSTEM TYPE	Select from list	<b>SAME AS LEAD</b>
	TEMPERATURES	Max Supply	<b>SAME AS LEAD</b>
		Min Supply	<b>SAME AS LEAD</b>
		Max OD Reset	<b>SAME AS LEAD</b>
		Min OD Reset	<b>SAME AS LEAD</b>
		Modulate On Diff	<b>10 F</b>
		Modulate Off Diff	<b>5 F</b>
	TIMES	Max On Time	<b>0 minutes</b>
		Boost Interval Prepump Time: Postpump Time:	D D D
	CIRCULATORS	Circulator 1	<b>OFF</b>
Circulator 2		<b>ON</b>	
Circulator 3		<b>OFF</b>	
MAXIMUM RATE		D	
MINIMUM RATE		D	
<b>BOILER PRIORITY 2</b> DHW	SYSTEM TYPE	Select from list	<b>DHW-DIRECT</b>
	TEMPERATURES	Max Supply	<b>190 F</b>
		Max OD Reset	D
		Min OD Reset	D
		Modulate On Diff	D
		Modulate Off Diff	D
		Max On Time	D
	TIMES	Min On Time	<b>60 minutes</b>
		Boost Interval Prepump Time: Postpump Time:	D D D
		Circulator 1 Circulator 2 Circulator 3	<b>ON</b> <b>OFF</b> <b>OFF</b>
MAXIMUM RATE			D
MINIMUM RATE		D	
<b>BOILER PRIORITY 3</b> Not used	SYSTEM TYPE	Select from list	D
	TEMPERATURES	Max Supply	D
		Min Supply	D
		Max OD Reset	D
		Min OD Reset	D
		Modulate On Diff	D
		Modulate Off Diff	D
	TIMES	Min On Time	D
		Boost Interval Prepump Time: Postpump Time:	D D D
		Circulator 1 Circulator 2 Circulator 3	D D D
MAXIMUM RATE			D
MINIMUM RATE		D	
CIRCULATOR EXERCISING	Circulator 1 Circulator 2 Circulator 3	D D D	
FREEZE PROTECT CIRCS	Circulator 1 Circulator 2 Circulator 3	D D D	



# Appendix A

## OUTDOOR RESET Settings and Troubleshooting

### Outdoor reset control settings

**NOTICE**

Outdoor reset can improve comfort and operating efficiency, making the best possible use of the Ultra boiler's condensing ability. Improperly setting outdoor reset settings in the U-Control can result in insufficient heat. Factory default settings for the U-Control will work in many instances, but not all. Use the information below to set the control to meet the installation conditions.

1. Outdoor reset tries to match heat input to the system heat loss. As outdoor temperature rises (heat loss decreases), the U-Control reduces the supply water temperature to the system, thus reducing heat input.
2. Setup desired settings for each of the priorities used
3. **MIN and MAX SUPPLY temperatures** — For an explanation of the target temperatures and associated outdoor temperatures, see Figure 1.
  - a. **MAX OD RESET** means the outdoor temperature at which the target temperature reaches its maximum value (MAX SUPPLY). In the example of Figure 1, this occurs at 0°F outside (the factory default setting).  
MAX OD RESET should equal the **ODT** (outdoor design temperature) for the installation's location.
  - b. **MAX SUPPLY** should equal the required supply water temperature for the system at design maximum heat loss (typically 180°F for finned tube baseboard on new installations).
  - c. **MIN OD RESET** means the outdoor temperature at which the target temperature reaches its minimum (MIN SUPPLY). In the example of Figure 1, this occurs at 70°F (the factory default).
  - d. **MIN SUPPLY** should equal the desired minimum supply water temperature for the system. The factory default is 130°F. This could be set as low as 70°F, which would supply “zero heat” when outdoor temperature is 70°F, because supply water temp would equal room temp. See examples in Figure 1.
  - e. Note that the reset lines are curved. The shape of this curve is matched (characterized) to the response of the system type chosen. This ensures the most effective reset operation.
4. **Modulate on differential** — The temperature must drop this many degrees below target temperature for the boiler to come on.
5. **Modulate off differential** — While the boiler is firing, as the temperature increases above the target temperature, the boiler firing rate is reduced. At this many degrees above the target temperature, the boiler shuts down.
6. **Boost interval** — This adjustment is located in the TIMES menus. The boost timer starts on a call for heat. If the boost interval time passes and the call for heat is still on, the U-Control “boosts” the supply water temperature setpoint by 10°F. This occurs again if another boost interval elapses. Boost will continue until the setpoint reaches the MAX SUPPLY setting. The purpose of boost is to compensate for changes in demand not addressed by the reset curve. Typically, set boost to 30 minutes. The factory default is “OFF” — that is, boost is not enabled with default settings.

### Troubleshooting insufficient heat calls

1. Insufficient heat can occur if the supply water temperature to the heating units is not hot enough. Possibly reasons are:
  - a. The factory default settings for outdoor reset are not a good match to the system needs.
  - b. The baseboard may have been sized for higher water supply temperature. Older systems were often sized for baseboard supply temperature of 210°F (average water temperature of 200°F).
  - c. See additional potential causes in the NOTICE below.

Figure 1 Typical outdoor reset curves

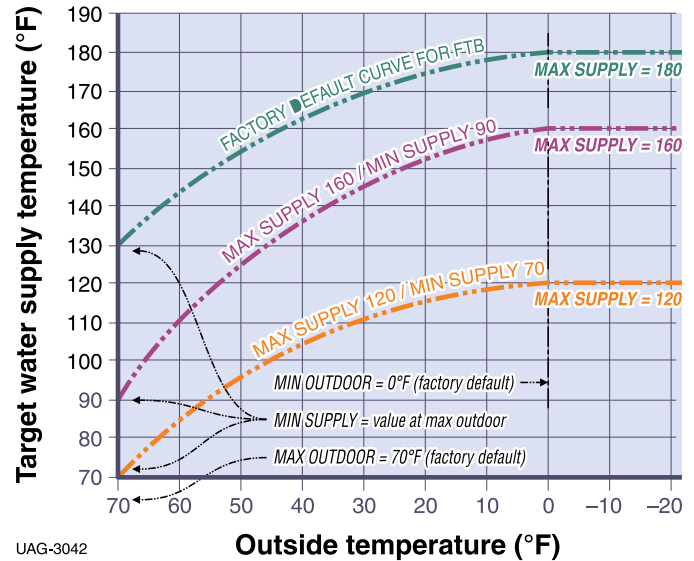

UAG-3042

2. One way to check whether water supply temperature is the problem is to measure the water temperature going to the heating units. Then see if this is reasonable by:
  - a. Look up the heating unit output rating at 190°F.
  - b. Look up the heating unit output rating at the water temperature you measured.
  - c. Measure the current outside temperature.
  - d. Look up the ODT (outdoor design temperature) for the area.
  - e. At this outside temperature, the heating unit output should be about equal to:  

$$\text{Output} = (\text{output at } 190^\circ\text{F}) \times (70 - \text{outside temp}) / (70 - \text{ODT})$$
3. Make sure the outdoor sensor is properly shielded so it isn't heating up due to solar gain. To verify, measure outside temperature and compare to the value shown on the U-Control display. If the sensor is shielded and still reading incorrectly, change the ADJUST OUTDOOR setting in the Boiler Settings menu.
4. In the event of an insufficient heat call, make the following adjustments to ensure the U-Control is delivering the best possible performance for the application.
  - a. **MAX OD RESET** — Set to a value of ODT (outdoor design temp for the location) PLUS 15°F. (Example: for an ODT of 10°F, set to 10° + 15° = 25°F.)
  - b. **MAX SUPPLY** — Set to 190°F. (Exception: For radiant systems, set to design operating temperature at maximum heat load.)
  - c. **MIN OD RESET** — Set to 70°F (factory default).
  - d. **MIN SUPPLY** — Set to 70°F (increase value to 130°F if the problem persists).
  - e. **BOOST INTERVAL** — Set to 30 minutes.

**NOTICE**

If the insufficient heat issue persists after making the adjustments recommended here, look for other possible causes, such as:

If the problem only occurs in some areas of the home, the heating units there may be undersized, or the problem area may not have control over boiler operation. Additional heating units or a zoning change may correct the problem. Other issues, such as air in the system, poor flow distribution or too little flow can also cause insufficient heat.





# Appendix B

## BOILER SETTINGS menu detail

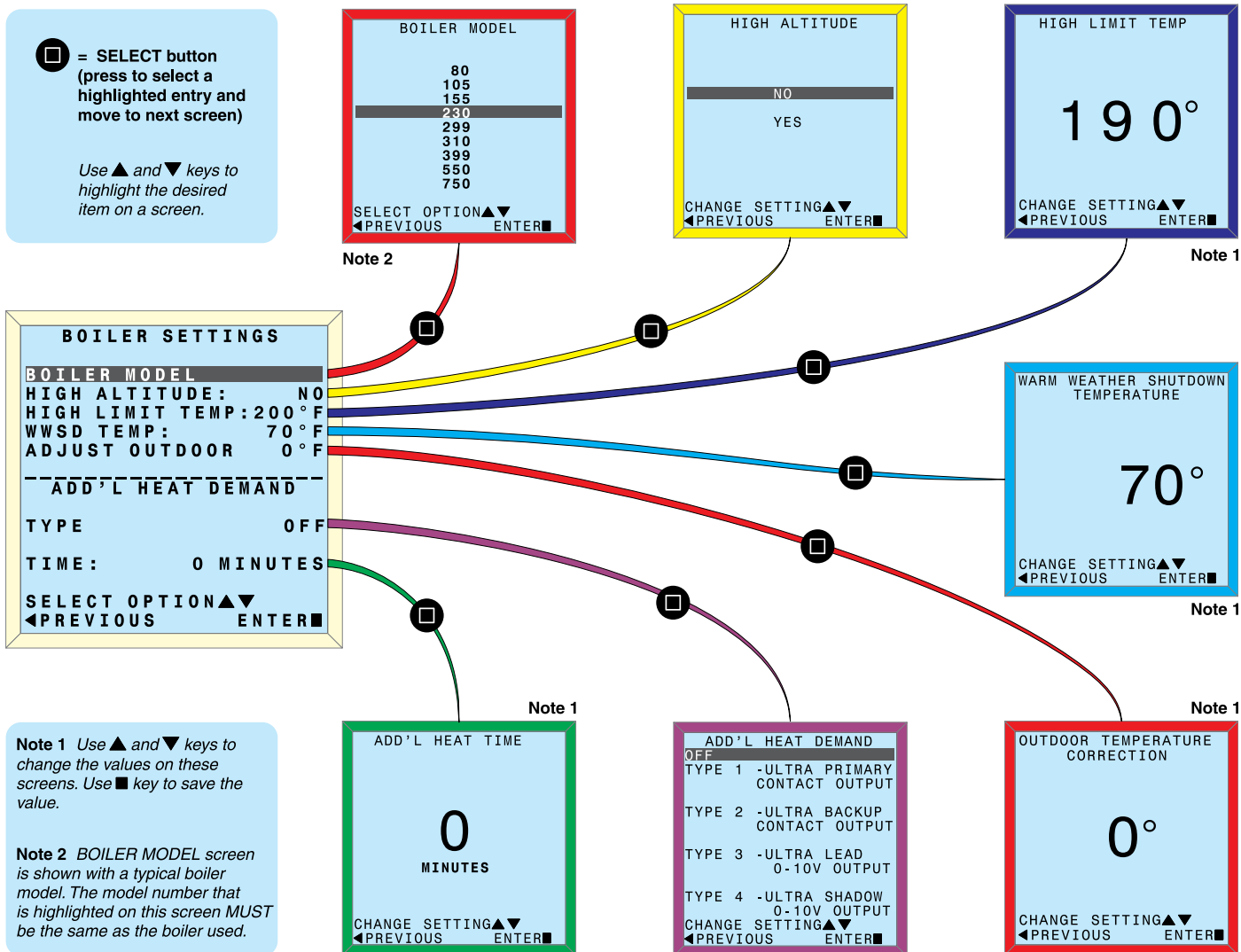



# Appendix C

## SYSTEM SETTINGS menu detail

**□** = SELECT button  
(press to select a highlighted entry and move to next screen)

Use ▲ and ▼ keys to highlight the desired item on a screen.

